



# BOARD QUESTION PAPER: MARCH 2025

## Mathematics Part - II

Time: 2 Hours

Max. Marks: 40

**Note:**

- All questions are compulsory.
- Use of a calculator is not allowed.
- The numbers to the right of the questions indicate full marks.
- In case of MCQs [Q. No. 1(A)] only the first attempt will be evaluated and will be given credit.
- Draw proper figures wherever necessary.
- The marks of construction should be clear. Do not erase them.
- Diagram is essential for writing the proof of the theorem.

**Q.1. (A) Choose the correct alternative from given:** [4]

- Out of the following which is a Pythagorean triplet?  
(A) (1, 5, 10) (B) (3, 4, 5)  
(C) (2, 2, 2) (D) (5, 5, 2)
- $\angle ACB$  is inscribed angle in a circle with centre O. If  $\angle ACB = 65^\circ$ , then what is measure of its intercepted arc AXB?  
(A)  $65^\circ$  (B)  $230^\circ$   
(C)  $295^\circ$  (D)  $130^\circ$
- Distance of point (3, 4) from the origin is \_\_\_\_\_.  
(A) 7 (B) 1  
(C) 5 (D) -5
- If radius of cone is 5 cm and its perpendicular height is 12 cm, then the slant height is \_\_\_\_\_.  
(A) 17 cm (B) 4 cm  
(C) 13 cm (D) 60 cm

**(B) Solve the following sub-questions:** [4]

- In the following figure  $\triangle ABC$ ,  $B - D - C$  and  $BD = 7$ ,  $BC = 20$ , then find  $\frac{A(\triangle ABD)}{A(\triangle ABC)}$ .

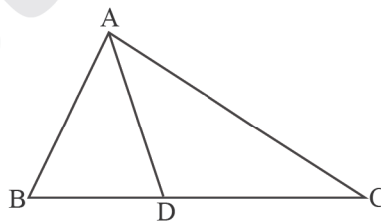

- In the following figure  $\angle MNP = 90^\circ$ , seg  $NQ \perp$  seg  $MP$ ,  $MQ = 9$ ,  $QP = 4$ , find  $NQ$ .

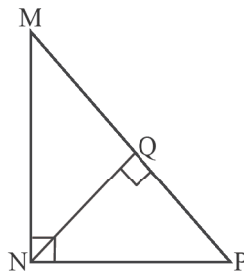

- Angle made by a line with the positive direction of X-axis is  $30^\circ$ . Find slope of that line.
- In cyclic quadrilateral ABCD  $m\angle A = 100^\circ$ , then find  $m\angle C$ .



[4]

**Q.2. (A) Complete the following activities and rewrite it (any two):**

- i. The radius of a circle with centre 'P' is 10 cm. If chord AB of the circle subtends a right angle at P, find area of minor sector by using the following activity. ( $\pi = 3.14$ )

**Activity:**

$$r = 10 \text{ cm}, \theta = 90^\circ, \pi = 3.14.$$

$$\begin{aligned} A(P\text{-}AXB) &= \frac{\theta}{360} \times \square \\ &= \frac{\square}{360} \times 3.14 \times 10^2 \\ &= \frac{1}{4} \times \square \end{aligned}$$

$$A(P\text{-}AXB) = \square \text{ sq.cm.}$$

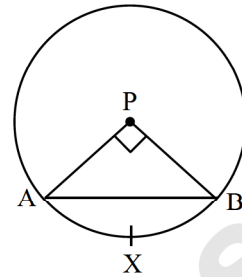

- ii. In the following figure chord MN and chord RS intersect at point D. If RD = 15, DS = 4, MD = 8, find DN by completing the following activity:

**Activity:**

$$\therefore MD \times DN = \square \times DS \text{ _____}$$

...(Theorem of internal division of chords)

$$\therefore \square \times DN = 15 \times 4$$

$$\therefore DN = \frac{\square}{8}$$

$$\therefore DN = \square$$

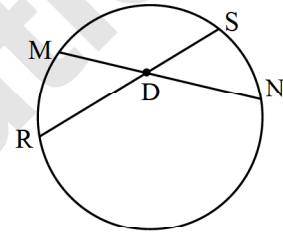

- iii. An observer at a distance of 10 m from tree looks at the top of the tree, the angle of elevation is  $60^\circ$ . To find the height of tree complete the activity. ( $\sqrt{3} = 1.73$ )

**Activity:**

In the figure given, AB = h = height of tree, BC = 10 m, distance of the observer from the tree.

$$\text{Angle of elevation } (\theta) = \angle BCA = 60^\circ$$

$$\tan \theta = \frac{\square}{BC} \quad \dots(i)$$

$$\tan 60^\circ = \frac{\square}{10} \quad \dots(ii)$$

$$\frac{AB}{BC} = \sqrt{3} \quad \dots[\text{from (i) and (ii)}]$$

$$AB = BC \times \sqrt{3} = 10\sqrt{3}$$

$$AB = 10 \times 1.73 = \square$$

$$\therefore \text{height of the tree is } \square \text{ m.}$$

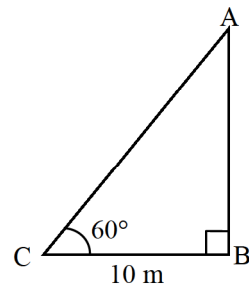

**(B) Solve the following sub-questions (any four):**

[8]

- i. In  $\triangle ABC$ ,  $DE \parallel BC$ . If  $DB = 5.4 \text{ cm}$ ,  $AD = 1.8 \text{ cm}$ ,  $EC = 7.2 \text{ cm}$ , then find AE.

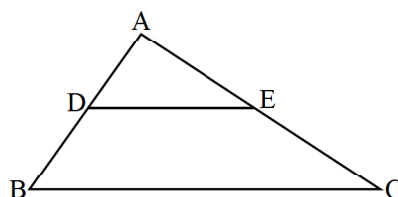



- ii. In the figure given below, find RS and PS using the information given in  $\Delta PSR$ .

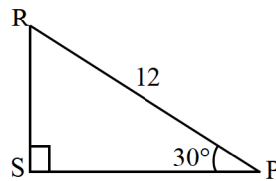

- iii. In the following figure, circle with centre D touches the sides of  $\angle ACB$  at A and B. If  $\angle ACB = 52^\circ$ , find measure of  $\angle ADB$ .

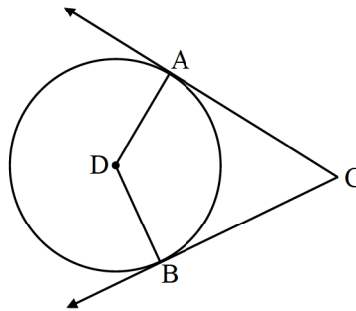

- iv. Verify, whether points, A(1, -3), B(2, -5) and C(-4, 7) are collinear or not.
- v. If  $\sin \theta = \frac{11}{61}$ , find the values of  $\cos \theta$  using trigonometric identity.

**Q.3. (A) Complete the following activities and rewrite it (any one):**

[3]

- i. In the following figure,  $XY \parallel \text{seg } AC$ . If  $2AX = 3BX$  and  $XY = 9$ . Complete the activity to find the value of AC.

**Activity:**

$$2AX = 3BX$$

...[Given]

$$\therefore \frac{AX}{BX} = \frac{3}{\boxed{\phantom{000}}}$$

$$\frac{AX+BX}{BX} = \frac{3+2}{2}$$

...[by componendo]

$$\frac{\boxed{\phantom{000}}}{BX} = \frac{5}{2}$$

...(i)

Now  $\Delta BCA \sim \Delta BYX$

...[ $\boxed{\phantom{000}}$  test of similarity]

$$\therefore \frac{BA}{BX} = \frac{AC}{XY}$$

...[corresponding sides of similar triangles]

$$\frac{\boxed{\phantom{000}}}{\boxed{\phantom{000}}} = \frac{AC}{9}$$

...[from (i)]

$$\therefore AC = \boxed{\phantom{000}}$$

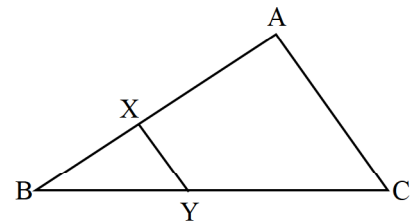

- ii. Complete the following activity to prove that the sum of squares of diagonals of a rhombus is equal to the sum of the squares of the sides.

**Given:**

$\square PQRS$  is a rhombus. Diagonals PR and SQ intersect each other at point T.

**To prove:**

$$PS^2 + SR^2 + QR^2 + PQ^2 = PR^2 + QS^2$$

**Activity:**

Diagonals of a rhombus bisect each other.

In  $\Delta PQS$ , PT is the median and in  $\Delta QRS$ , RT is the median.

- $\therefore$  by Apollonius theorem,

$$PQ^2 + PS^2 = \boxed{\phantom{000}} + 2QT^2 \quad \dots(i)$$

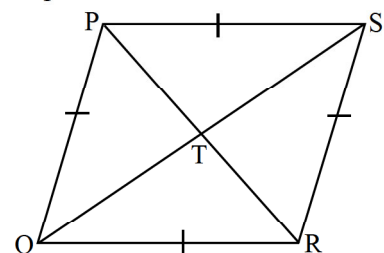



$$QR^2 + SR^2 = \boxed{\phantom{000}} + 2QT^2 \quad \dots(ii)$$

adding (i) and (ii),

$$PQ^2 + PS^2 + QR^2 + SR^2$$

$$= 2(PT^2 + \boxed{\phantom{000}}) + 4QT^2$$

$$= 2(PT^2 + \boxed{\phantom{000}}) + 4QT^2 \quad \dots(RT = PT)$$

$$= 4PT^2 + 4QT^2$$

$$= (\boxed{\phantom{000}})^2 + (2QT)^2$$

$$\therefore PQ^2 + PS^2 + QR^2 + SR^2 = PR^2 + \boxed{\phantom{000}}.$$

**(B) Solve the following sub-questions (any two):**

[6]

- i. Show that points P(1, -2), Q(5, 2), R(3, -1), S(-1, -5) are the vertices of a parallelogram.
- ii. Prove that tangent segments drawn from an external point to a circle are congruent.
- iii. Draw a circle with radius 4.1 cm. Construct tangents to the circle from a point at a distance 7.3 cm from the centre.
- iv. How many solid cylinders of radius 10 cm and height 6 cm can be made by melting a solid sphere of radius 30 cm?

**Q.4. Solve the following sub-questions (any two):**

[8]

- i. In the following figure  $DE \parallel BC$ , then:
  - a. If  $DE = 4$  cm,  $BC = 8$  cm,  $A(\triangle ADE) = 25$  cm<sup>2</sup>, find  $A(\triangle ABC)$ .
  - b. If  $DE : BC = 3 : 5$ , then find  $A(\triangle ADE) : A(\square DBCE)$ .

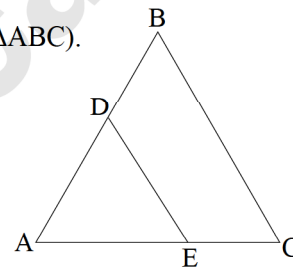

- ii.  $\triangle ABC \sim \triangle PQR$ . In  $\triangle ABC$ ,  $AB = 3.6$  cm,  $BC = 4$  cm and  $AC = 4.2$  cm. The corresponding sides of  $\triangle ABC$  and  $\triangle PQR$  are in the ratio  $2 : 3$ , construct  $\triangle ABC$  and  $\triangle PQR$ .
- iii. The radii of the circular ends of a frustum of a cone are 14 cm and 8 cm. If the height of the frustum is 8 cm, find: ( $\pi = 3.14$ )
  - a. Curved surface area of frustum.
  - b. Total surface area of the frustum.
  - c. Volume of the frustum.

**Q.5. Solve the following sub-questions (any one):**

[3]

- i.  $\square ABCD$  is a rectangle. Taking  $AD$  as a diameter, a semicircle  $AXD$  is drawn which intersects the diagonal  $BD$  at  $X$ . If  $AB = 12$  cm,  $AD = 9$  cm, then find the values of  $BD$  and  $BX$ .
- ii. Taking  $\theta = 30^\circ$  to verify the following Trigonometric identities:
  - a.  $\sin^2 \theta + \cos^2 \theta = 1$
  - b.  $1 + \tan^2 \theta = \sec^2 \theta$
  - c.  $1 + \cot^2 \theta = \text{cosec}^2 \theta$ .



# BOARD QUESTION PAPER: MARCH 2024

## Mathematics Part - II

Time: 2 Hours

Max. Marks: 40

Note:

- i. All questions are compulsory.
- ii. Use of a calculator is not allowed.
- iii. The numbers to the right of the questions indicate full marks.
- iv. In case of MCQs [Q. No. 1(A)] only the first attempt will be evaluated and will be given credit.
- v. Draw proper figures wherever necessary.
- vi. The marks of construction should be clear. Do not erase them.
- vii. Diagram is essential for writing the proof of the theorem.

**Q.1. (A) Four alternative answers for each of the following sub-questions are given. Choose the alternative and write its alphabet:** [4]

1. Out of the dates given below which date constitutes a Pythagorean triplet?  
(A) 15/8/17      (B) 16/8/16      (C) 3/5/17      (D) 4/9/15
2.  $\sin \theta \times \operatorname{cosec} \theta = ?$   
(A) 1      (B) 0      (C)  $\frac{1}{2}$       (D)  $\sqrt{2}$
3. Slope of X-axis is \_\_\_\_\_  
(A) 1      (B) -1      (C) 0      (D) Cannot be determined
4. A circle having radius 3 cm, then the length of its largest chord is \_\_\_\_\_.  
(A) 1.5 cm      (B) 3 cm      (C) 6 cm      (D) 9 cm

**(B) Solve the following sub-questions:** [4]

1. If  $\triangle ABC \sim \triangle PQR$  and  $AB : PQ = 2 : 3$ , then find the value of  $\frac{A(\triangle ABC)}{A(\triangle PQR)}$ .
2. Two circles of radii 5 cm and 3 cm touch each other externally. Find the distance between their centres.
3. Find the side of a square whose diagonal is  $10\sqrt{2}$  cm.
4. Angle made by the line with the positive direction of X-axis is  $45^\circ$ . Find the slope of that line.

**Q.2. (A) Complete any two activities and rewrite it:** [4]

1.

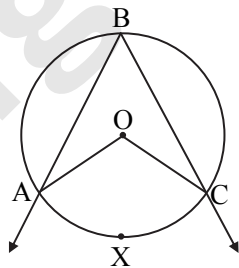

In the above figure,  $\angle ABC$  is inscribed in arc ABC.

If  $\angle ABC = 60^\circ$ , find  $m\angle AOC$ .

**Solution:**

$$\angle ABC = \frac{1}{2} m(\text{arc } AXC) \quad \dots \boxed{\phantom{000}}$$

$$60^\circ = \frac{1}{2} m(\text{arc } AXC)$$

$$\boxed{\phantom{000}} = m(\text{arc } AXC)$$



But  $m\angle AOC = \boxed{m(\text{arc} \dots)}$

...[Property of central angle]

$\therefore m\angle AOC = \boxed{\phantom{000}}$

2. Find the value of  $\sin^2\theta + \cos^2\theta$ .

**Solution:**

In  $\Delta ABC$ ,  $\angle ABC = 90^\circ$ ,  $\angle C = \theta^\circ$ .

$AB^2 + BC^2 = \boxed{\phantom{000}}$

...[Pythagoras theorem]

Divide both sides by  $AC^2$

$$\frac{AB^2}{AC^2} + \frac{BC^2}{AC^2} = \frac{AC^2}{AC^2}$$

$\therefore \left(\frac{AB}{AC}\right)^2 + \left(\frac{BC}{AC}\right)^2 = 1$

But  $\frac{AB}{AC} = \boxed{\phantom{000}}$  and  $\frac{BC}{AC} = \boxed{\phantom{000}}$

$\therefore \sin^2\theta + \cos^2\theta = \boxed{\phantom{000}}$

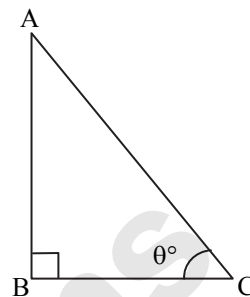

3.

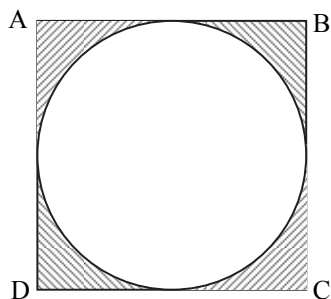

In the figure given above,  $\square ABCD$  is a square and a circle is inscribed in it. All sides of a square touch the circle.

If  $AB = 14$  cm, find the area of shaded region.

**Solution:**

Area of square =  $(\boxed{\phantom{000}})^2$  ...[Formula]

=  $14^2$

=  $\boxed{\phantom{000}}$   $\text{cm}^2$

Area of circle =  $\boxed{\phantom{000}}$  ...[Formula]

=  $\frac{22}{7} \times 7 \times 7$

=  $154 \text{ cm}^2$

Area of shaded portion = Area of square – Area of circle

=  $196 - 154$

=  $\boxed{\phantom{000}}$   $\text{cm}^2$

**(B) Solve any four of the following sub-questions:**

[8]

1. Radius of a sector of a circle is 3.5 cm and length of its arc is 2.2 cm. Find the area of the sector.
2. Find the length of the hypotenuse of a right-angled triangle if remaining sides are 9 cm and 12 cm.



3.

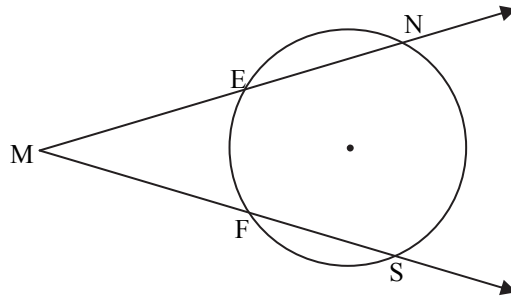

In the above figure,  $m(\text{arc NS}) = 125^\circ$ ,  $m(\text{arc EF}) = 37^\circ$ .  
Find the measure of  $\angle \text{NMS}$ .

4. Find the slope of the line passing through the points A(2, 3), B(4, 7).

5. Find the surface area of a sphere of radius 7 cm.

**Q.3. (A) Complete any one activity of the following and rewrite it:****[3]**

1.

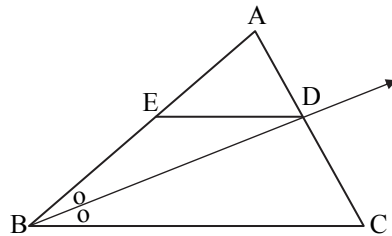

In  $\triangle ABC$ , ray BD bisects  $\angle ABC$ ,  $A - D - C$ , seg  $DE \parallel$  side BC,  $A - E - B$ , then for showing

$\frac{AB}{BC} = \frac{AE}{EB}$ , complete the following activity:

**Proof:**

In  $\triangle ABC$ , ray BD bisects  $\angle B$

$$\therefore \frac{\boxed{\phantom{000}}}{BC} = \frac{AD}{DC} \quad \dots(\text{I}) \quad (\boxed{\phantom{000}})$$

In  $\triangle ABC$ ,  $DE \parallel BC$

$$\therefore \frac{\boxed{\phantom{000}}}{EB} = \frac{AD}{DC} \quad \dots(\text{II}) \quad (\boxed{\phantom{000}})$$

$$\frac{AB}{\boxed{\phantom{000}}} = \frac{\boxed{\phantom{000}}}{EB} \quad \dots[\text{From (I) and (II)}]$$

2.

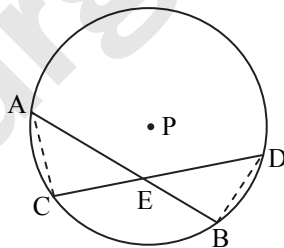

**Given:** Chords AB and CD of a circle with centre P intersect at point E.

**To prove:**  $AE \times EB = CE \times ED$

**Construction:** Draw seg AC and seg BD.

Fill in the blank and complete the proof.

**Proof:**

In  $\triangle CAE$  and  $\triangle BDE$ .

$$\angle AEC \cong \angle DEB \quad \dots \quad \boxed{\phantom{000}}$$

$$\boxed{\phantom{000}} \cong \angle BDE \quad (\text{angles inscribed in the same arc})$$



$\therefore \triangle CAE \sim \triangle BDE$  ...   
 $\therefore \frac{\square}{DE} = \frac{CE}{\square}$  ...   
 $\therefore AE \times EB = CE \times ED.$

**(B) Solve any two of the following sub-questions:** [6]

- Determine whether the points are collinear.  
A(1, -3), B(2, -5), C(-4, 7)
- $\triangle ABC \sim \triangle LMN$ . In  $\triangle ABC$ , AB = 5.5 cm, BC = 6 cm, CA = 4.5 cm. Construct  $\triangle ABC$  and  $\triangle LMN$  such that  $\frac{BC}{MN} = \frac{5}{4}$ .
- Seg PM is a median of  $\triangle PQR$ , PM = 9 and  $PQ^2 + PR^2 = 290$ , then find QR.
- Prove that, 'If a line parallel to a side of a triangle intersects the remaining sides in two distinct points, then the line divides the side in the same proportion.'

**Q.4. Solve any two of the following sub-questions:** [8]

- $\frac{1}{\sin^2 \theta} - \frac{1}{\cos^2 \theta} - \frac{1}{\tan^2 \theta} - \frac{1}{\cot^2 \theta} - \frac{1}{\sec^2 \theta} - \frac{1}{\operatorname{cosec}^2 \theta} = -3$ , then find the value of  $\theta$ .
- A cylinder of radius 12 cm contains water up to the height 20 cm. A spherical iron ball is dropped into the cylinder and thus water level raised by 6.75 cm. What is the radius of iron ball?
- Draw a circle with centre O having radius 3 cm. Draw tangent segments PA and PB through the point P outside the circle such that  $\angle APB = 70^\circ$ .

**Q.5. Solve any one of the following sub-questions:** [3]

- $\square ABCD$  is trapezium, AB  $\parallel$  CD diagonals of trapezium intersects in point P.  
Write the answers of the following questions:
  - Draw the figure using given information.
  - Write any one pair of alternate angles and opposite angles.
  - Write the names of similar triangles with test of similarity.
- AB is a chord of a circle with centre O. AOC is diameter of circle, AT is a tangent at A.  
Write answers of the following questions:
  - Draw the figure using given information.
  - Find the measures of  $\angle CAT$  and  $\angle ABC$  with reasons.
  - Whether  $\angle CAT$  and  $\angle ABC$  are congruent? Justify your answer.



# BOARD QUESTION PAPER: JULY 2023

## Mathematics Part - II

Time: 2 Hours

Max. Marks: 40

Note:

- All questions are compulsory.
- Use of calculator is not allowed.
- The numbers to the right of the questions indicate full marks.
- In case of MCQs [Q. No. 1(A)] only the first attempt will be evaluated and will be given credit.
- For every MCQ, the correct alternative (A), (B), (C) or (D) with sub-question number is to be written as an answer.
- Draw proper figures for answers wherever necessary.
- The marks of construction should be clear. Do not erase them.
- Diagram is essential for writing the proof of the theorem.

**Q.1. (A) For each of the following sub-question four alternative answers are given. Choose the correct alternative and write its alphabet:** [4]

- The volume of a cube of side 10 cm is \_\_\_\_\_.  
(A)  $1 \text{ cm}^3$  (B)  $10 \text{ cm}^3$  (C)  $100 \text{ cm}^3$  (D)  $1000 \text{ cm}^3$
- A line makes an angle of  $30^\circ$  with positive direction of X-axis, then the slope of the line is \_\_\_\_\_.  
(A)  $\frac{1}{2}$  (B)  $\frac{\sqrt{3}}{2}$  (C)  $\frac{1}{\sqrt{3}}$  (D)  $\sqrt{3}$
- $\angle ACB$  is inscribed in arc  $ACB$  of a circle with centre  $O$ . If  $\angle ACB = 65^\circ$ , find  $m(\text{arc } ACB)$  :  
(A)  $65^\circ$  (B)  $130^\circ$  (C)  $295^\circ$  (D)  $230^\circ$
- Find the perimeter of a square if its diagonal is  $10\sqrt{2}$  cm.  
(A) 10 cm (B)  $40\sqrt{2}$  cm (C) 20 cm (D) 40 cm

**(B) Solve the following sub-questions:**

[4]

- In the following figure,  $\angle ABC = \angle DCB = 90^\circ$ ,  $AB = 6$ ,  $DC = 8$ , then  $\frac{A(\triangle ABC)}{A(\triangle DCB)} = ?$

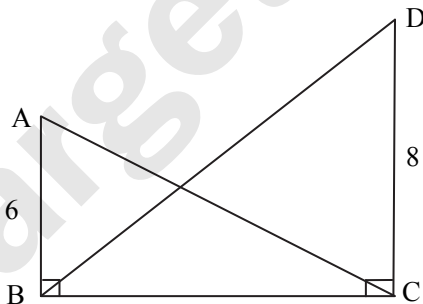

- In the following figure, find the length of RP using the information given in  $\triangle PSR$ .

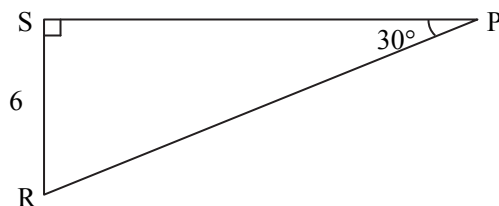

- What is the distance between two parallel tangents of a circle having radius 4.5 cm?
- Find the co-ordinates of midpoint of the segment joining the points  $A(4, 6)$  and  $B(-2, 2)$ .



Q.2. (A) Complete the following activities and rewrite it (any two):

[4]

1.

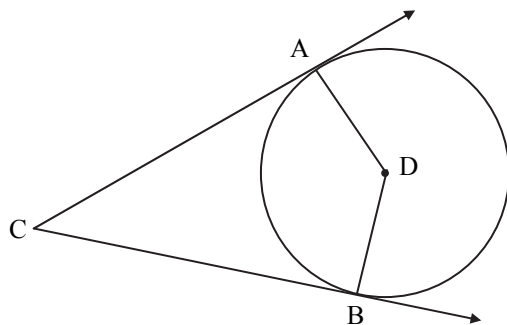

In the above figure, circle with centre D touches the sides of  $\angle ACB$  at A and B. If  $\angle ACB = 52^\circ$ , complete the activity to find the measure of  $\angle ADB$ .

**Activity:**

In  $\square ABCD$ ,

$\angle CAD = \angle CBD = \square^\circ$  ..... Tangent theorem

$\therefore \angle ACB + \angle CAD + \angle CBD + \angle ADB = \square^\circ$

$\therefore 52^\circ + 90^\circ + 90^\circ + \angle ADB = 360^\circ$

$\therefore \angle ADB + \square^\circ = 360^\circ$

$\angle ADB = 360^\circ - 232^\circ$

$\therefore \angle ADB = \square^\circ$

2.

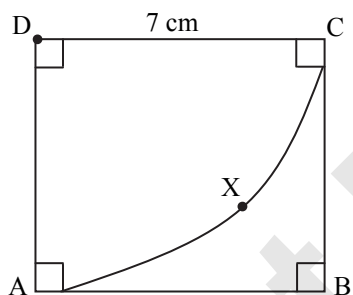

In the above figure, side of square ABCD is 7 cm with centre D and radius DA sector D-AXC is drawn.

Complete the following activity to find the area of square ABCD and sector D-AXC.

**Activity:**

Area of square =  $\square$  ..... formula

$= (7)^2$   
 $= 49 \text{ cm}^2$

Area of sector (D-AXC) =  $\square$  ..... formula

$= \frac{\square}{360} \times \frac{22}{7} \times \square$   
 $= 38.5 \text{ cm}^2$

3. Complete the following activity to prove  $\cot \theta + \tan \theta = \text{cosec } \theta \times \sec \theta$ .

**Activity:**

L.H.S. =  $\cot \theta + \tan \theta$

$= \frac{\square}{\sin \theta} + \frac{\sin \theta}{\cos \theta}$

$= \frac{\square + \square}{\sin \theta \cdot \cos \theta}$



$$\begin{aligned}
 &= \frac{1}{\sin \theta \cdot \cos \theta} \quad (\because \sin^2 \theta + \cos^2 \theta = 1) \\
 &= \frac{1}{\sin \theta} \times \frac{1}{\cos \theta} \\
 &= \square \times \sec \theta
 \end{aligned}$$

$\therefore$  L.H.S. = R.H.S.

$\therefore$   $\cot \theta + \tan \theta = \operatorname{cosec} \theta \times \sec \theta$

**(B) Solve the following sub-questions (Any four):**

[8]

1. If  $\cos \theta = \frac{3}{5}$ , then find  $\sin \theta$ .

2. Find slope of line EF, where co-ordinates of E are  $(-4, -2)$  and co-ordinates of F are  $(6, 3)$ .

3.

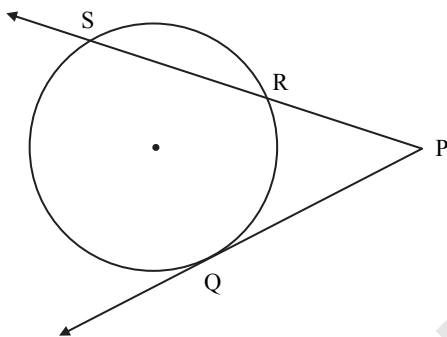

In the above figure, ray PQ touches the circle at point Q. If  $PQ = 12$ ,  $PR = 8$ , find the length of seg PS.

4.

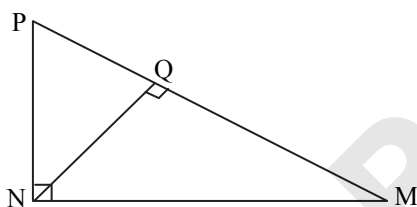

In the above figure,  $\angle MNP = 90^\circ$ , seg  $NQ \perp$  seg  $MP$ .  $MQ = 9$ ,  $QP = 4$ . Find  $NQ$ .

5.

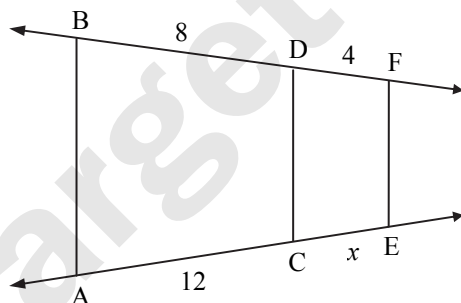

In the above figure, if  $AB \parallel CD \parallel EF$ , then find  $x$  and  $AE$  by using the information given in the figure.

**Q.3. (A) Complete the following activities and rewrite it (any one):**

[3]

1.

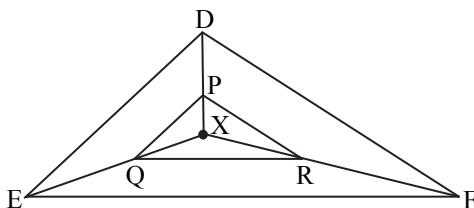

In the above figure, X is any point in the interior of triangle. Point X is joined to vertices of triangle seg  $PQ \parallel$  seg  $DE$ , seg  $QR \parallel$  seg  $EF$ . Complete the following activity to prove seg  $PR \parallel$  seg  $DF$ .



**Activity :**

In  $\triangle XDE$ ,  $PQ \parallel DE$  .....(given)  
 $\therefore \frac{XP}{QE} = \frac{XD}{DE}$  .....(I) Basic proportionality theorem  
 In  $\triangle XEF$ ,  $QR \parallel EF$  .....(given)  
 $\therefore \frac{XQ}{RF} = \frac{XE}{EF}$  .....(II)   
 $\therefore \frac{XP}{PD} = \frac{XQ}{QF}$  .....from (I) and (II)  
 $\therefore$  seg  $PR \parallel$  seg  $DF$  .....Converse of basic proportionality theorem

2.

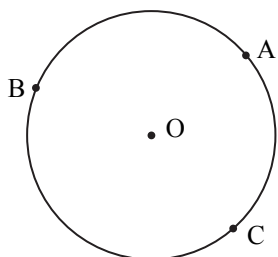

A, B, C are any points on the circle with centre O.  
 If  $m(\text{arc } BC) = 110^\circ$  and  $m(\text{arc } AB) = 125^\circ$ , complete the following activity to find  $m(\text{arc } ABC)$ ,  $m(\text{arc } AC)$ ,  $m(\text{arc } ACB)$  and  $m(\text{arc } BAC)$ .

**Activity :**

$$m(\text{arc } ABC) = m(\text{arc } AB) + \text{[ ]}$$

$$= \text{[ ]}^\circ + 110^\circ$$

$$= 235^\circ$$

$$m(\text{arc } AC) = 360^\circ - m(\text{arc } \text{[ ]})$$

$$= 360^\circ - \text{[ ]}^\circ$$

$$= 125^\circ$$

Similarly

$$m(\text{arc } ACB) = 360^\circ - \text{[ ]}$$

$$= 235^\circ$$

and  $m(\text{arc } BAC) = 360^\circ - \text{[ ]}$

$$= 250^\circ$$

**(B) Solve the following sub-questions (any two):**

[6]

- The radius of a circle is 6 cm, the area of a sector of this circle is  $15\pi$  sq.cm. Find the measure of the arc and the length of the arc corresponding to that sector.
- If A(3, 5) and B(7, 9), point Q divides seg AB in the ratio 2 : 3, find the co-ordinates of point Q.
- Prove that :  
 “In a right-angled triangle, the square of the hypotenuse is equal to the sum of the squares of remaining two sides.”
- $\triangle PQR \sim \triangle LTR$ . In  $\triangle PQR$ ,  $PQ = 4.2$  cm,  $QR = 5.4$  cm,  $PR = 4.8$  cm. Construct  $\triangle PQR$  and  $\triangle LTR$  such that  $\frac{PQ}{LT} = \frac{3}{4}$ .

**Q.4. Solve the following sub-questions (any two):**

[8]

- A bucket is in the form of a frustum of a cone. It holds 28.490 litres of water. The radii of the top and the bottom are 28 cm and 21 cm respectively. Find the height of the bucket.  $\left(\pi = \frac{22}{7}\right)$



2. Draw a circle with centre P and radius 3 cm. Draw a chord MN of length 4 cm. Draw tangents to the circle through points M and N which intersect in point Q. Measure the length of seg PQ.
3. In  $\Delta PQR$ , bisectors of  $\angle Q$  and  $\angle R$  intersect in point X. Line PX intersects side QR in point Y, then prove that:  $\frac{PQ + PR}{QR} = \frac{PX}{XY}$ .

**Q.5. Solve the following sub-questions (Any one):****[3]**

1. From top of the building, Ramesh is looking at a bicycle parked at some distance away from the building on the road.  
If  
AB  $\rightarrow$  Height of building is 40 m  
C  $\rightarrow$  Position of bicycle  
A  $\rightarrow$  Position of Ramesh on top of the building  
 $\angle MAC$  is the angle of depression and  $m\angle MAC = 30^\circ$ , then:
  - (a) Draw a figure with the given information.
  - (b) Find the distance between building and the bicycle. ( $\sqrt{3} = 1.73$ ).
2.  $\square$  ABCD is a cyclic quadrilateral where side AB  $\cong$  side BC,  $\angle ADC = 110^\circ$ , AC is the diagonal, then:
  - (a) Draw the figure using given information
  - (b) Find measure of  $\angle ABC$
  - (c) Find measure of  $\angle BAC$
  - (d) Find measure of (arc ABC).



# BOARD QUESTION PAPER: MARCH 2023

## Mathematics Part - II

Time: 2 Hours

Max. Marks: 40

**Note:**

- i. All questions are compulsory.
- ii. Use of calculator is not allowed.
- iii. The numbers to the right of the questions indicate full marks.
- iv. In case of MCQs [Q. No. 1(A)] only the first attempt will be evaluated and will be given credit.
- v. For every MCQ, the correct alternative (A), (B), (C) or (D) with sub-question number is to be written as an answer.
- vi. Draw the proper figures for answers wherever necessary.
- vii. The marks of construction should be clear and distinct. Do not erase them.
- viii. Diagram is essential for writing the proof of the theorem.

**Q.1. (A) Four alternative answers are given for every subquestion. Select the correct alternative and write the alphabet of that answer:** [4]

1. If  $a, b, c$  are sides of a triangle and  $a^2 + b^2 = c^2$ , name the type of triangle:  
 (A) Obtuse angled triangle (B) Acute angled triangle  
 (C) Right angled triangle (D) Equilateral triangle
2. Chords AB and CD of a circle intersect inside the circle at point E. If  $AE = 4, EB = 10, CE = 8$ , then find ED:  
 (A) 7 (B) 5 (C) 8 (D) 9
3. Co-ordinates of origin are \_\_\_\_\_.  
 (A) (0, 0) (B) (0, 1) (C) (1, 0) (D) (1, 1)
4. If radius of the base of cone is 7 cm and height is 24 cm, then find its slant height:  
 (A) 23 cm (B) 26 cm (C) 31 cm (D) 25 cm

**(B) Solve the following sub-questions:** [4]

1. If  $\triangle ABC \sim \triangle PQR$  and  $\frac{A(\triangle ABC)}{A(\triangle PQR)} = \frac{16}{25}$ , then find  $AB : PQ$ .
2. In  $\triangle RST$ ,  $\angle S = 90^\circ, \angle T = 30^\circ, RT = 12$  cm, then find RS.
3. If radius of a circle is 5 cm, then find the length of longest chord of a circle.
4. Find the distance between the points  $O(0, 0)$  and  $P(3, 4)$ .

**Q.2. (A) Complete the following activities (any two):** [4]

1.

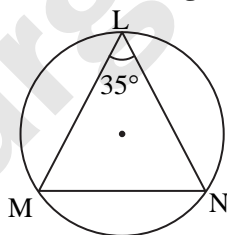

In the above figure,  $\angle L = 35^\circ$ , find:

- i.  $m(\text{arc } MN)$
- ii.  $m(\text{arc } MLN)$

**Solution:**

i.  $\angle L = \frac{1}{2} m(\text{arc } MN)$  ... (By inscribed angle theorem)

$\therefore \square = \frac{1}{2} m(\text{arc } MN)$

$\therefore 2 \times 35 = m(\text{arc } MN)$

$\therefore m(\text{arc } MN) = \square$



ii.  $m(\text{arc MLN}) = \square - m(\text{arc MN}) \dots(\text{Definition of measure of arc})$   
 $= 360^\circ - 70^\circ$   
 $\therefore m(\text{arc MLN}) = \square$

2. Show that,  $\cot\theta + \tan\theta = \text{cosec}\theta \times \sec\theta$

**Solution:**

L.H.S =  $\cot\theta + \tan\theta$   
 $= \frac{\cos\theta}{\sin\theta} + \frac{\sin\theta}{\cos\theta}$   
 $= \frac{\square}{\sin\theta \times \cos\theta} + \frac{\square}{\sin\theta \times \cos\theta}$   
 $= \frac{1}{\sin\theta \times \cos\theta} \dots \square$   
 $= \frac{1}{\sin\theta} \times \frac{1}{\square}$   
 $= \text{cosec}\theta \times \sec\theta$

L.H.S = R.H.S

$\therefore \cot\theta + \tan\theta = \text{cosec}\theta \times \sec\theta$

3. Find the surface area of a sphere of radius 7 cm.

**Solution:**

Surface area of sphere =  $4\pi r^2$   
 $= 4 \times \frac{22}{7} \times \square^2$   
 $= 4 \times \frac{22}{7} \times \square$   
 $= \square \times 7$

$\therefore$  Surface area of sphere =  $\square$  sq.cm.

(B) Solve the following sub-questions(Any four):

[8]

1.

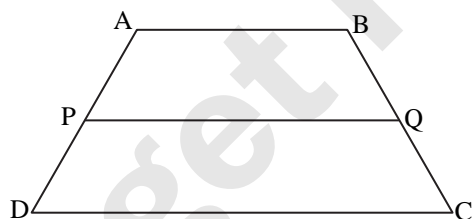

In trapezium ABCD side  $AB \parallel$  side  $PQ \parallel$  side  $DC$ .  $AP = 15$ ,  $PD = 12$ ,  $QC = 14$ , find  $BQ$ .

2. Find the length of the diagonal of a rectangle whose length is 35 cm and breadth is 12 cm.

3.

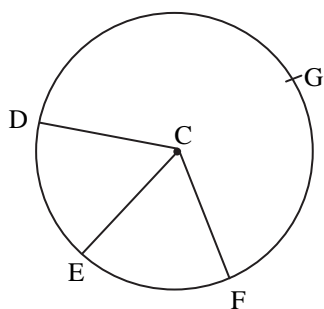

In the given figure points G, D, E, F are points of a circle with centre C,  $\angle ECF = 70^\circ$ ,  $m(\text{arc DGF}) = 200^\circ$ .

Find:

- i.  $m(\text{arc DE})$       ii.  $m(\text{arc DEF})$ .



- Show that points  $A(-1, -1)$ ,  $B(0, 1)$ ,  $C(1, 3)$  are collinear.
- A person is standing at a distance of 50 m from a temple looking at its top. The angle of elevation is of  $45^\circ$ . Find the height of the temple.

**Q.3. (A) Complete the following activities (any one):**

[3]

1.

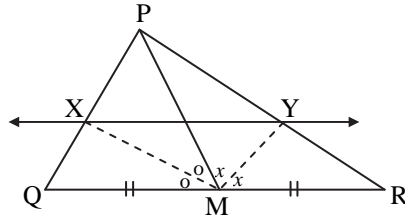

In  $\Delta PQR$ , seg  $PM$  is a median. Angle bisectors of  $\angle PMQ$  and  $\angle PMR$  intersect side  $PQ$  and side  $PR$  in points  $X$  and  $Y$  respectively. Prove that  $XY \parallel QR$ .  
Complete the proof by filling in the boxes.

**Solution:**

In  $\Delta PMQ$ ,

Ray  $MX$  is the bisector of  $\angle PMQ$

$$\therefore \frac{MP}{MQ} = \frac{PX}{XQ} \quad \dots\text{(I) [Theorem of angle bisector]}$$

Similarly, in  $\Delta PMR$ , Ray  $MY$  is bisector of  $\angle PMR$

$$\therefore \frac{MP}{MR} = \frac{PY}{YR} \quad \dots\text{(II) [Theorem of angle bisector]}$$

$$\text{But } \frac{MP}{MQ} = \frac{MP}{MR} \quad \dots\text{(III) [As } M \text{ is the midpoint of } QR\text{]}$$

Hence  $MQ = MR$

$$\therefore \frac{PX}{XQ} = \frac{PY}{YR} \quad \dots\text{[From (I), (II) and (III)]}$$

$$\therefore XY \parallel QR \quad \dots\text{[Converse of basic proportionality theorem]}$$

- Find the co-ordinates of point  $P$  where  $P$  is the midpoint of a line segment  $AB$  with  $A(-4, 2)$  and  $B(6, 2)$ .

**Solution:**

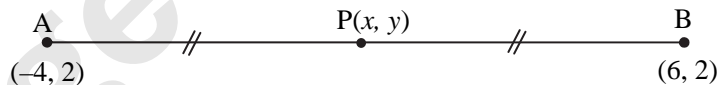

Suppose,  $(-4, 2) = (x_1, y_1)$  and  $(6, 2) = (x_2, y_2)$  and co-ordinates of  $P$  are  $(x, y)$

$\therefore$  According to midpoint theorem,

$$x = \frac{x_1 + x_2}{2} = \frac{-4 + 6}{2} = \frac{2}{2} = 1$$

$$y = \frac{y_1 + y_2}{2} = \frac{2 + 2}{2} = \frac{4}{2} = 2$$

$\therefore$  Co-ordinates of midpoint  $P$  are  $(1, 2)$

**(B) Solve the following sub-questions (any two):**

[6]

- In  $\Delta ABC$ , seg  $AP$  is a median. If  $BC = 18$ ,  $AB^2 + AC^2 = 260$ , find  $AP$ .
- Prove that, "Angles inscribed in the same arc are congruent".
- Draw a circle of radius 3.3 cm. Draw a chord  $PQ$  of length 6.6 cm. Draw tangents to the circle at points  $P$  and  $Q$ .
- The radii of circular ends of a frustum are 14 cm and 6 cm respectively and its height is 6 cm. Find its curved surface area. ( $\pi = 3.14$ )



**Q.4. Solve the following sub-questions (any two):**

[8]

1. In  $\triangle ABC$ , seg  $DE \parallel$  side  $BC$ . If  $2A(\triangle ADE) = A(\square DBCE)$ , find  $AB : AD$  and show that  $BC = \sqrt{3} DE$ .
2.  $\triangle SHR \sim \triangle SVU$ . In  $\triangle SHR$ ,  $SH = 4.5$  cm,  $HR = 5.2$  cm,  $SR = 5.8$  cm and  $\frac{SH}{SV} = \frac{3}{5}$ , construct  $\triangle SVU$ .
3. An ice-cream pot has a right circular cylindrical shape. The radius of the base is 12 cm and height is 7 cm. This pot is completely filled with ice-cream. The entire ice-cream is given to the students in the form of right circular ice-cream cones, having diameter 4 cm and height is 3.5 cm. If each student is given one cone, how many students can be served?

**Q.5. Solve the following sub-questions (any one):**

[3]

1.

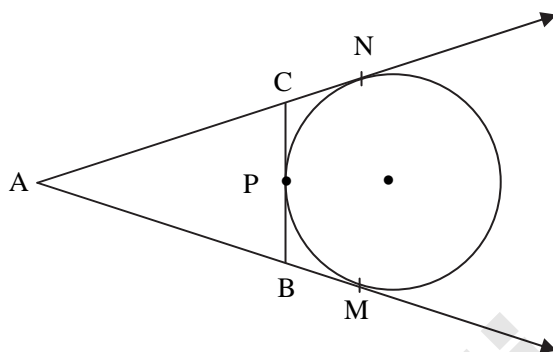

A circle touches side  $BC$  at point  $P$  of the  $\triangle ABC$ , from out-side of the triangle. Further extended lines  $AC$  and  $AB$  are tangents to the circle at  $N$  and  $M$  respectively.

Prove that:  $AM = \frac{1}{2}$  (Perimeter of  $\triangle ABC$ )

2. Eliminate  $\theta$  if  $x = r \cos \theta$  and  $y = r \sin \theta$ .



# BOARD QUESTION PAPER: JULY 2024

## Mathematics Part - II

Time: 2 Hours

Max. Marks: 40

Note:

- All questions are compulsory.
- Use of a calculator is not allowed.
- The numbers to the right of the questions indicate full marks.
- In case of MCQs [Q. No. 1(A)] only the first attempt will be evaluated and will be given credit.
- For every MCQ, the correct alternative (A), (B), (C) or (D) with subquestion number is to be written as an answer.
- Draw proper figures of answers wherever necessary.
- The marks of construction should be clear. Do not erase them.
- Diagram is essential for writing the proof of the theorem.

Q.1. (A) For each of the following subquestions four alternative answers are given. Choose the alternative and write its alphabet: [4]

1. In  $\triangle ABC$  and  $\triangle PQR$ , in a one to one correspondence of vertices,  $\frac{AB}{QR} = \frac{BC}{PR} = \frac{CA}{PQ}$ , then \_\_\_\_\_ statement is true.

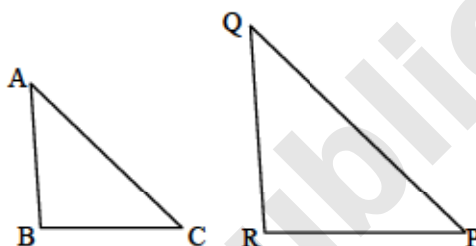

- (A)  $\triangle PQR \sim \triangle ABC$  (B)  $\triangle PQR \sim \triangle CAB$   
(C)  $\triangle CBA \sim \triangle PQR$  (D)  $\triangle BCA \sim \triangle PQR$
2. Two circles of radii 5.5 cm and 3.3 cm respectively touch each other externally. Then the distance between their centres is \_\_\_\_\_  
(A) 4.4 cm (B) 8.8 cm  
(C) 2.2 cm (D) 8.3 cm
3. Seg AB is parallel to Y-axis and co-ordinates of point A are (1, 3), then co-ordinates of point B are \_\_\_\_\_  
(A) (3, 1) (B) (5, 3)  
(C) (3, 0) (D) (1, -3)
4. The volume of a cube of side 10 cm is \_\_\_\_\_  
(A)  $1000 \text{ cm}^3$  (B)  $100 \text{ cm}^3$   
(C)  $10,000 \text{ cm}^3$  (D)  $10 \text{ cm}^3$

(B) Solve the following sub-questions: [4]

1.

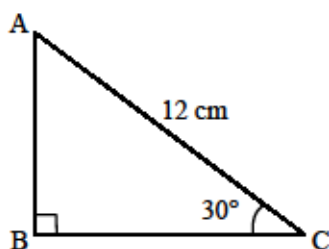

In  $\triangle ABC$ ,  $\angle B = 90^\circ$ ,  $\angle C = 30^\circ$ ,  $AC = 12 \text{ cm}$ , then find AB.



2.

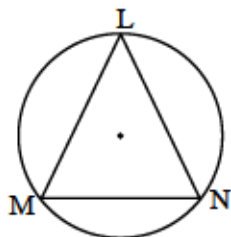

In the above figure,  $m(\text{arc } MN) = 70^\circ$ , find  $\angle MLN$ .

3. Find the value of  $\sin \theta \times \operatorname{cosec} \theta$ .
4. If radius of a circle is 4 cm and length of an arc is 10 cm, then find the area of the sector.

Q.2. (A) Complete the following activities and rewrite it (any two): [4]

1.

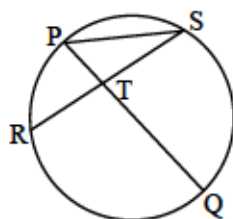

In the above figure, chord PQ and chord RS intersect at point T. Then complete the following activity to prove,

$$\angle STQ = \frac{1}{2} [m(\text{arc } SQ) + m(\text{arc } PR)]$$

Activity:

$$\begin{aligned} \angle STQ &= \angle SPQ + \boxed{\phantom{000}} && \dots [\text{Remote interior angles theorem of a triangle}] \\ &= \frac{1}{2} m(\text{arc } SQ) + \boxed{\phantom{000}} && \dots [\text{Inscribed angle theorem}] \\ &= \frac{1}{2} [\boxed{\phantom{000}} + \boxed{\phantom{000}}] \end{aligned}$$

2. If  $\sec \theta = \frac{25}{7}$ , complete the following activity to find the value of  $\tan \theta$ .

Activity:

We have,

$$1 + \tan^2 \theta = \sec^2 \theta$$

$$\therefore 1 + \tan^2 \theta = \boxed{\phantom{000}}$$

$$\therefore \tan^2 \theta = \frac{625}{49} - \boxed{\phantom{000}}$$

$$\therefore \tan^2 \theta = \frac{625 - 49}{49}$$

$$\therefore \tan^2 \theta = \frac{\boxed{\phantom{000}}}{49}$$

$$\therefore \tan \theta = \boxed{\phantom{000}}$$

3. Complete the following activity to find the volume of a cone if the radius of its base is 7 cm and its perpendicular height is 6 cm.

Activity:

Here, radius ( $r$ ) = 7 cm

height ( $h$ ) = 6 cm



∴ Volume of cone =  ...[Formula]

$$= \frac{1}{3} \times \frac{22}{7} \times \text{} \times 6$$

$$= \frac{1}{3} \times \frac{22}{7} \times \text{} \times 6$$

∴ Volume of cone =  cm<sup>3</sup>

(B) Solve the following sub-questions (any four):

[8]

1. Construct a tangent to a circle with centre P and radius 3.2 cm at any point M on it.

2.

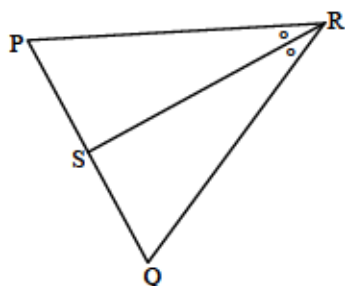

In  $\Delta PQR$ , seg RS bisects  $\angle PRQ$ . If  $PR = 15$ ,  $RQ = 20$ ,  $PS = 12$ , then find  $SQ$ .

3. Find the surface area of a sphere of diameter 14 cm.

4.

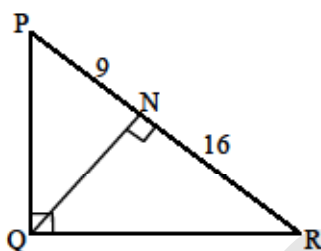

In the above figure,  $\angle PQR = 90^\circ$ , seg  $QN \perp$  seg  $PR$ ,  $PN = 9$ ,  $NR = 16$ , find  $QN$ .

5. Find the slope of the line passing through the points  $A(3, 3)$  and  $B(5, 7)$ .

Q.3. (A) Complete the following activities and rewrite it (any one):

[3]

1.

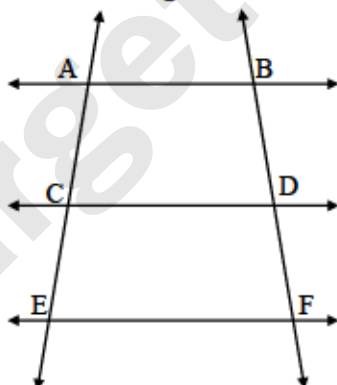

In the given figure,  $AB \parallel CD \parallel EF$ . If  $AC = 12$ ,  $CE = 9$ ,  $BD = 8$ , then complete the following activity to find  $DF$ .

Activity:

$AB \parallel CD \parallel EF$

∴  $\frac{AC}{\text{}}{DF}$

...[Property of three parallel lines and their transversal]

∴  $\frac{12}{\text{}}{DF}$



$$\therefore DF = \frac{8 \times 9}{\square}$$

$$\therefore DF = \square$$

2. A cylinder is having radius 7 cm and height 21 cm. Complete the following activity to calculate its volume and circumference of its base.

**Activity:**

Radius ( $r$ ) = 7 cm

Height ( $h$ ) = 21 cm

Volume of cylinder =  $\square$  ...[Formula]

$$= \frac{22}{7} \times 7 \times 7 \times \square$$

$$= 154 \times 21$$

$$= \square \text{ cm}^3$$

Circumference of base =  $\square$  ...[Formula]

$$= 2 \times \frac{22}{7} \times \square$$

$$= \square \text{ cm}$$

(B) Solve the following subquestions (any two):

[6]

1. Prove that, 'Opposite angles of a cyclic quadrilateral are supplementary'.
2. Draw a circle with centre P and radius 3.5 cm. Take point Q at a distance 8 cm from the centre. Construct tangents to the circle from point Q.
3. Show that points P(-2, 3), Q(1, 2), R(4, 1) are collinear.
4. If  $\Delta PQR \sim \Delta LMN$ ,  $9 \times A(\Delta PQR) = 16 \times A(\Delta LMN)$  and  $QR = 20$ , then find MN.

Q.4. Solve the following subquestions (any two):

[8]

1.  $\Delta ABC$  is an equilateral triangle. Point D is on seg BC such that  $BD = \frac{1}{5} BC$ . Then prove that

$$\frac{AD^2}{AB^2} = \frac{21}{25}$$

2.  $\Delta LMN \sim \Delta LQP$ . In  $\Delta LMN$ ,  $LM = 3.6$  cm,  $\angle L = 50^\circ$ ,  $LN = 4.2$  cm and  $\frac{LM}{LQ} = \frac{4}{7}$ .

Construct  $\Delta LQP$ .

3. To find the width of the river, a man observes the top of a tree, on the opposite bank making an angle of elevation of  $60^\circ$ . When he moves 24 meter backward from bank and observes the same top of the tree, his line of vision makes an angle of elevation of  $30^\circ$ . Find the height of the tree and width of the river. ( $\sqrt{3} = 1.73$ )

Q.5. Solve the following sub-questions (any one):

[3]

1. The diameter of circular garden is 13 meter. The distance between two gates of garden is 13 meter. An electric pole is to be erected on the circumference of the garden such that the difference between distance of the pole form each gate is 7 meter. Can such pole be erected? If yes, find the distance of the pole form each gate.
2. The line  $x - 6y + 11 = 0$  bisects the segment joining the points (8, -1) and (0, k), then find the value of k.



# BOARD QUESTION PAPER: MARCH 2022

## Mathematics - II

Time: 2 Hours

Max. Marks: 40

Note:

- i. All questions are compulsory.
- ii. Use of calculator is not allowed.
- iii. The numbers to the right of the questions indicate full marks.
- iv. In case of MCQs [Q. No. 1(A)] only the first attempt will be evaluated and will be given credit.
- v. For every MCQ, the correct alternative (A), (B), (C) or (D) with sub-question number is to be written as an answer.
- vi. Draw proper figures for answers wherever necessary.
- vii. The marks of construction should be clear. Do not erase them.
- viii. Diagram is essential for writing the proof of the theorem.

**Q.1. (A) For each of the following sub-questions four alternative answers are given. Choose the correct alternative and write its alphabet:** [4]

- i. If  $\triangle ABC \sim \triangle DEF$  and  $\angle A = 48^\circ$ , then  $\angle D =$  \_\_\_\_\_.  
(A)  $48^\circ$       (B)  $83^\circ$       (C)  $49^\circ$       (D)  $132^\circ$
- ii. AP is a tangent at A drawn to the circle with center O from an external point P.  $OP = 12$  cm and  $\angle OPA = 30^\circ$ , then the radius of a circle is \_\_\_\_\_.  
(A) 12 cm      (B)  $6\sqrt{3}$  cm      (C) 6 cm      (D)  $12\sqrt{3}$  cm
- iii. Seg AB is parallel to X-axis and co-ordinates of the point A are (1, 3), then the co-ordinates of the point B can be \_\_\_\_\_.  
(A) (-3, 1)      (B) (5, 1)      (C) (3, 0)      (D) (-5, 3)
- iv. The value of  $2\tan 45^\circ - 2\sin 30^\circ$  is \_\_\_\_\_.  
(A) 2      (B) 1      (C)  $\frac{1}{2}$       (D)  $\frac{3}{4}$

**(B) Solve the following sub-questions:** [4]

- i. In  $\triangle ABC$ ,  $\angle ABC = 90^\circ$ ,  $\angle BAC = \angle BCA = 45^\circ$ .

If  $AC = 9\sqrt{2}$ , then find the value of AB.

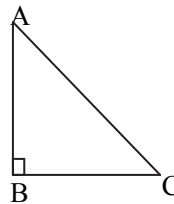

- ii. Chord AB and chord CD of a circle with centre O are congruent. If  $m(\text{arc AB}) = 120^\circ$ , then find the  $m(\text{arc CD})$ .
- iii. Find the Y-co-ordinate of the centroid of a triangle whose vertices are (4, -3), (7, 5) and (-2, 1).
- iv. If  $\sin\theta = \cos\theta$ , then what will be the measure of angle  $\theta$ ?

**Q.2. (A) Complete the following activities and rewrite it (any two):** [4]

- i. In the above figure, seg AC and seg BD intersect each other in point P. If  $\frac{AP}{CP} = \frac{BP}{DP}$ , then complete the following activity to prove  $\triangle ABP \sim \triangle CDP$ .

**Activity:** In  $\triangle APB$  and  $\triangle CDP$

$$\frac{AP}{CP} = \frac{BP}{DP} \dots\dots \square$$

$\therefore \angle APB \equiv \square$  ..... vertically opposite angles

$\therefore \square \sim \triangle CDP$ .....  $\square$  test of similarity.

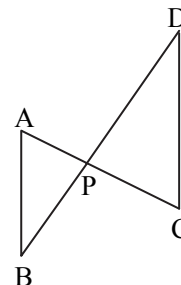



- ii. In the above figure, □ABCD is a rectangle. If AB = 5, AC = 13, then complete the following activity to find BC.

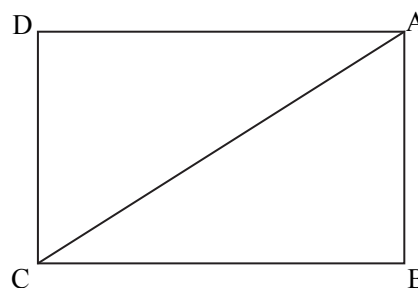

**Activity:**

ΔABC is □ triangle.

∴ By Pythagoras theorem  
 $AB^2 + BC^2 = AC^2$

∴  $25 + BC^2 = \square$  ∴  $BC^2 = \square$

∴  $BC = \square$

- iii. Complete the following activity to prove:  $\cot\theta + \tan\theta = \operatorname{cosec}\theta \times \sec\theta$

**Activity:**

L.H.S. =  $\cot\theta + \tan\theta$

$$= \frac{\cos\theta}{\sin\theta} + \frac{\square}{\cos\theta} = \frac{\square + \sin^2\theta}{\sin\theta \times \cos\theta}$$

$$= \frac{1}{\sin\theta \times \cos\theta} \dots \therefore \square = \frac{1}{\sin\theta} \times \frac{1}{\cos\theta}$$

$$= \square \times \sec\theta$$

∴ L.H.S. = R.H.S.

**(B) Solve the following sub-questions (any four):**

[8]

- i. If ΔABC ~ ΔPQR, AB : PQ = 4 : 5 and A(ΔPQR) = 125 cm<sup>2</sup>, then find A(ΔABC).

ii.

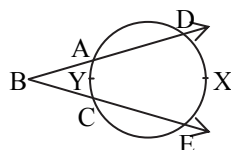

In the above figure,  $m(\text{arc } DXE) = 105^\circ$ ,  $m(\text{arc } AYC) = 47^\circ$ , then find the measure of ∠DBE.

- iii. Draw a circle of radius 3.2 cm and centre 'O'. Take any point P on it. Draw tangent to the circle through point P using the centre of the circle.

- iv. If  $\sin\theta = \frac{11}{61}$ , then find the value of  $\cos\theta$  using trigonometric identity.

- v. In ΔABC, AB = 9 cm, BC = 40 cm, AC = 41 cm. State whether ΔABC is a right-angled triangle or not? Write reason.

**Q.3. (A) Complete the following activities and rewrite it (any one):**

[3]

i.

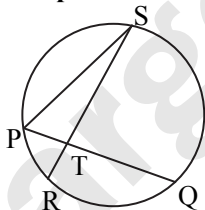

In the above figure, chord PQ and chord RS intersect each other at point T. If ∠STQ = 58° and ∠PSR = 24°, then complete the following activity to verify:  $\angle STQ = \frac{1}{2} [m(\text{arc } PR) + m(\text{arc } SQ)]$

**Activity:**

In ΔPTS,

$\angle SPQ = \angle STQ - \square$

∴ Exterior angle theorem

∴  $\angle SPQ = 34^\circ$

∴  $m(\text{arc } QS) = 2 \times \square^\circ = 68^\circ$

..... ∴  $\square$

Similarly  $m(\text{arc } PR) = 2\angle PSR = \square^\circ$

∴  $\frac{1}{2} [m(\text{arc } QS) + m(\text{arc } PR)] = \frac{1}{2} \times \square^\circ = 58^\circ$  ..... (I)



but  $\angle STQ = 58^\circ$

..... (II) given

$$\therefore \frac{1}{2} [m(\text{arc PR}) + m(\text{arc QS})] = \boxed{\angle \dots} \quad \text{..... from (I) and (II)}$$

- ii. Complete the following activity to find the co-ordinates of point P which divides seg AB in the ratio 3 : 1 where A(4, -3) and B(8, 5).

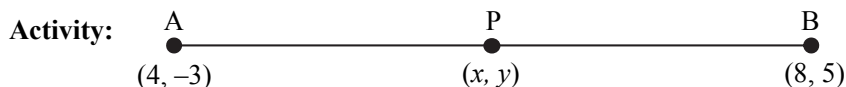

$\therefore$  By section formula,

$$x = \frac{mx_2 + nx_1}{m+n}, \quad y = \frac{\boxed{\phantom{00}}}{m+n}$$

$$\therefore x = \frac{3 \times 8 + 1 \times 4}{3+1}, \quad y = \frac{3 \times 5 + 1 \times (-3)}{3+1}$$

$$\therefore = \frac{\boxed{\phantom{00}} + 4}{4} = \frac{\boxed{\phantom{00}} - 3}{4}$$

$$\therefore x = \boxed{\phantom{00}} \quad \therefore y = \boxed{\phantom{00}}$$

**(B) Solve the following sub-questions (any two):**

- i. In  $\triangle ABC$ , seg  $XY \parallel$  side AC. If  $2AX = 3BX$  and  $XY = 9$ , then find the value of AC.

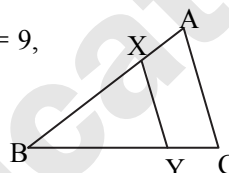

[6]

- ii. Prove that, "Opposite angles of cyclic quadrilateral are supplementary".  
 iii.  $\triangle ABC \sim \triangle PQR$ . In  $\triangle ABC$ ,  $AB = 5.4$  cm,  $BC = 4.2$  cm,  $AC = 6.0$  cm,  $AB : PQ = 3 : 2$ , then construct  $\triangle ABC$  and  $\triangle PQR$   
 iv. Show that:  $\frac{\tan A}{(1 + \tan^2 A)^2} + \frac{\cot A}{(1 + \cot^2 A)^2} = \sin A \times \cos A$ .

**Q.4. Solve the following sub-questions (any two):**

- i.  $\square ABCD$  is a parallelogram. Point P is the midpoint of side CD. Seg BP intersects diagonal AC at point X, then prove that:  
 $3AX = 2AC$

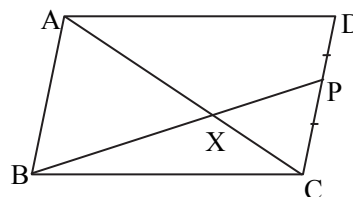

ii.

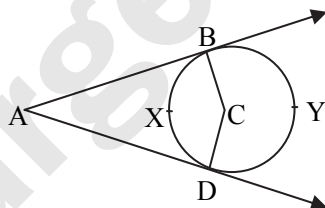

In the above figure, seg AB and seg AD are tangent segments drawn to a circle with centre C from exterior point A, then prove that:  $\angle A = \frac{1}{2} [m(\text{arc BYD}) - m(\text{arc BXD})]$

- iii. Find the co-ordinates of centroid of a triangle if points D(-7, 6), E(8, 5) and F(2, -2) are the mid-points of the sides of that triangle.

**Q.5. Solve the following sub-questions (any one):**

- i. If a and b are natural numbers and  $a > b$ . If  $(a^2 + b^2)$ ,  $(a^2 - b^2)$  and  $2ab$  are the sides of the triangle, then prove that the triangle is right angled.  
 Find out two Pythagorean triplets by taking suitable values of a and b.  
 ii. Construct two concentric circles with centre O with radii 3 cm and 5 cm. Construct tangent to a smaller circle from any point A on the larger circle. Measure and write the length of tangent segment. Calculate the length of tangent segment using Pythagoras theorem.

[3]



# BOARD QUESTION PAPER: JULY 2022

## Mathematics Part - II

Time: 2 Hours

Max. Marks: 40

Note:

- All questions are compulsory.
- Use of calculator is not allowed.
- The numbers to the right of the questions indicate full marks.
- In case of MCQs [Q. No. 1(A)] only the first attempt will be evaluated and will be given credit.
- For every MCQ, the correct alternative (A), (B), (C) or (D) with sub-question number is to be written as an answer.
- Draw proper figures for answers wherever necessary.
- The marks of construction should be clear. Do not erase them.
- Diagram is essential for writing the proof of the theorem.

**Q.1. (A) Four alternative answers are given for every sub-question. Select the correct alternative and write the alphabet of that answer:** [4]

- From the following points \_\_\_\_\_ point lies to the right side of the origin on X-axis.  
(A)  $(-2, 0)$  (B)  $(0, 2)$   
(C)  $(2, 3)$  (D)  $(2, 0)$
- $\Delta PQR \sim \Delta STU$  and  $A(\Delta PQR) : A(\Delta STU) = 64 : 81$ , then what is the ratio of corresponding sides?  
(A)  $8 : 9$  (B)  $64 : 81$   
(C)  $9 : 8$  (D)  $16 : 27$
- In a right angled triangle; if the sum of the squares of sides making right angle is 169, then what is the length of hypotenuse?  
(A) 15 (B) 13  
(C) 5 (D) 12
- If  $\tan \theta = \sqrt{3}$ , then the value of  $\theta$  is \_\_\_\_\_  
(A)  $60^\circ$  (B)  $30^\circ$   
(C)  $90^\circ$  (D)  $45^\circ$

**(B) Solve the following sub-questions:** [4]

- In the given figure, seg  $CB \perp$  seg  $AB$ , seg  $AD \perp$  seg  $AB$ .  
If  $BC = 4$ ,  $AD = 8$ ,  
then find  $\frac{A(\Delta ABC)}{A(\Delta ADB)}$ .

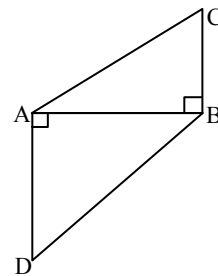

- Find the coordinates of the midpoint of the segment joining the points  $(22, 20)$  and  $(0, 16)$ .
- Two circles having radii 7 cm and 4 cm touch other internally. Find the distance between their centres.
- In  $\Delta ABC$ ,  $\angle B = 90^\circ$ ,  $\angle A = 30^\circ$ ,  $AC = 14$ , then find  $BC$ .

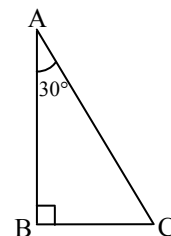



[4]

**Q.2. (A) Complete the following activities and rewrite it (any two):**

- i. In the above figure,  $\angle PQR$  is inscribed in the semicircle PQR.  
Complete the following activity to find measure of  $\angle PQR$ .

**Activity:**

$m(\text{arc PQR}) = 180^\circ$  ... (measure of semicircle)

$\therefore m(\text{arc PXR}) = \square$

$\therefore \angle PQR = \frac{1}{2} m(\text{arc } \square)$  ...

$= \frac{1}{2} \times 180^\circ$

$\therefore \angle PQR = \square$

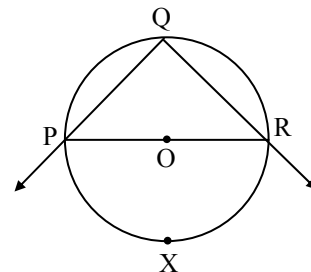

- ii. In  $\triangle ABC$ ,  $\angle B = 90^\circ$ ,  $\angle C = \theta^\circ$  then  
complete the activity to derive the trigonometric identity.

**Activity:**

$AB^2 + BC^2 = \square$  ... (Pythagoras theorem)

$\therefore \frac{AB^2}{AB^2} + \frac{BC^2}{AB^2} = \frac{AC^2}{AB^2}$  ... (dividing by  $AB^2$ )

$\therefore 1 + \frac{BC^2}{AB^2} = \frac{AC^2}{AB^2}$

But  $\frac{\square}{AB^2} = \cot^2 \theta$  and  $\frac{AC^2}{\square} = \text{cosec}^2 \theta$

$\therefore 1 + \square = \text{cosec}^2 \theta$

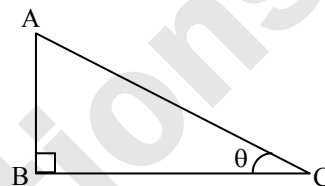

- iii. In  $\triangle PQR$ , if  $PN = 12$ ,  $NR = 8$ ,  $PM = 15$ ,  $MQ = 12$ , then complete the following activity to justify whether seg NM is parallel to side RQ or not.

**Activity:**

In  $\triangle PQR$ ,

$\frac{PN}{NR} = \frac{12}{\square} = \frac{3}{2}$  ... (i)

and  $\frac{PM}{MQ} = \frac{15}{12} = \frac{\square}{4}$  ... (ii)

$\therefore \frac{PN}{NR} \neq \frac{PM}{MQ}$  ... [from (i) and (ii)]

$\therefore$  By

seg NM is  to side RQ.

[Note : The activity has been modified.]

**(B) Solve the following sub-questions (Any four):**

[8]

- i. In the given figure,  
chord AC and chord DE intersect each other at point B.  
If  $\angle ABE = 108^\circ$  and  $m(\text{arc AE}) = 95^\circ$ ,  
Then find  $m(\text{arc DC})$ .

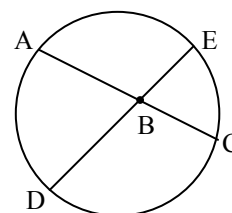

- ii. Find the distance between the points  $P(-1, 1)$  and  $Q(5, -7)$ .  
iii. Construct a tangent to a circle with centre P and radius 3.5 cm at any point M on it.  
iv. Find the length of diagonal of rectangle having sides 11 cm and 60 cm.  
v. If  $\sin \theta = \frac{7}{25}$ , then find values of  $\cos \theta$  and  $\tan \theta$ .

**Q.3. (A) Complete the following activities and rewrite it (any one):**

[3]

- i. In the above figure  
 $\angle QPR = 90^\circ$ , seg  $PM \perp$  seg  $QR$  and  $Q-M-R$ .  $PM = 10$ ,  
 $QM = 8$ . Complete the following activity to find the  
 value of  $QR$ .

**Activity:**

In  $\Delta PQR$ ,  $\angle QPR = 90^\circ$  and  
 seg  $PM \perp$  seg  $QR$

$$\therefore PM^2 = \square \times MR$$

$$\therefore (\square)^2 = 8 \times MR$$

$$\therefore \frac{100}{8} = MR$$

$$\therefore \square = MR$$

Now  $QR = QM + MR$

$$\therefore QR = 8 + \square$$

$$\therefore QR = \square$$

- ii. In the above figure, in  $\Delta ABC$  seg  $XY \parallel$  side  $AC$ ,  $A-X-B$ ,  $B-Y-C$   
 If  $2AX = 3BX$  and  $XY = 9$ ,  
 then complete the following activity to find value of  $AC$ .

**Activity:**

$2AX = 3BX$

$$\therefore \frac{AX}{BX} = \frac{\square}{\square}$$

$$\therefore \frac{AX+BX}{BX} = \frac{3+2}{A(\Delta PQR)}$$

$$\therefore \frac{AB}{BX} = \frac{5}{2}$$

$\Delta ABC \sim \Delta BYX$

$$\therefore \frac{BA}{BX} = \frac{AC}{\square}$$

$$\therefore \frac{BA}{BX} = \frac{AC}{\square}$$

$$\therefore AC = \square$$

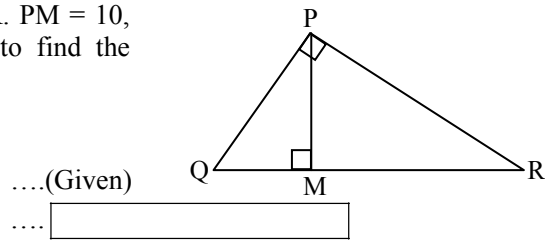

....(Given)

....

....( $\because$  Q-M-R)

....(Given)

....(Componendo)

....(i)

....( test of similarity)

....(c.s.s.t)

....[from (i)]

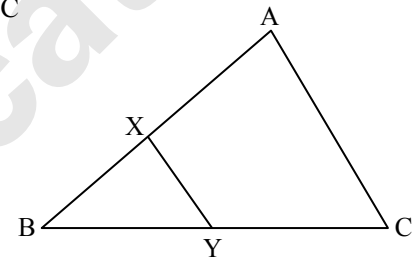
**(B) Solve the following sub-questions (any two):**

[6]

- Prove that  $\sec \theta + \tan \theta = \frac{\cos \theta}{1 - \sin \theta}$ .
- Find the coordinates of centroid of the triangle whose vertices are  $(4, 7)$ ,  $(8, 4)$ ,  $(7, 11)$ .
- Prove that "Opposite angles of a cyclic quadrilateral are supplementary".
- Draw a circle with centre  $O$  and radius  $3.5$  cm. take a point  $P$  at a distance  $7.5$  cm from the centre. Draw tangents to the circle from point  $P$ .

**Q.4. Solve the following sub-questions (any two):**

[8]

- i. In  $\Delta ABC$ , point  $X$  is any point on side  $BC$ .  
 seg  $XM \parallel$  seg  $AB$  and seg  $XN \parallel$  seg  $AC$ .  
 Extend seg  $MN$  such that it intersects extended  
 side  $CB$  in point  $T$ .  
 Then prove that  $TX^2 = TB \times TC$ .

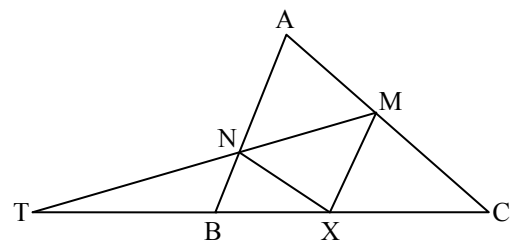



- ii. Draw triangle ABC, right angle at B such that AB = 3 cm, BC = 4 cm. Now construct  $\Delta PBQ$  similar to  $\Delta ABC$  each of whose sides are  $\frac{7}{4}$  times the corresponding sides of  $\Delta ABC$ .
- iii. In the given figure, points A, P, B, R, C, Q are on the circle. After joining the given points as shown in the figure it forms a hexagon, then prove that  $\angle APB + \angle BRC = 360^\circ - \angle AQC$ .

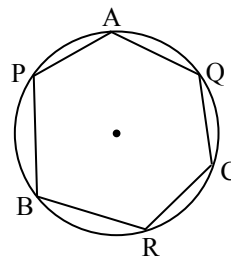

**Q.5. Solve the following sub-questions (Any one):**

- i.  $\Delta ABC$  and  $\Delta PQR$  are equilateral triangles with altitudes  $2\sqrt{3}$  and  $4\sqrt{3}$  respectively, then:
  - a. Find the length of side AB and side PQ
  - b. Find  $\frac{A(\Delta ABC)}{A(\Delta PQR)}$
  - c. Find the ratio of perimeter of  $\Delta ABC$  to the perimeter of  $\Delta PQR$ .
- ii. In a circle with centre O, PA and PB are tangents from an external point P. E is the point on the circle such that O-E-P. Tangent drawn at E intersects PA and PB in point C and D respectively. If PA = 10, then write the answers to the following questions:
  - a. Draw the suitable figure using given information.
  - b. Write the relation between seg PA and seg PB
  - c. Find the perimeter of  $\Delta PCD$ .

[3]



# BOARD QUESTION PAPER: MARCH 2020

## Mathematics Part - II

Time: 2 Hours

Max. Marks: 40

**Notes:**

- i. All questions are compulsory.
- ii. Use of calculator is not allowed.
- iii. The numbers to the right of the questions indicate full marks.
- iv. In case of MCQ's [Q. No. 1(A)] only the first attempt will be evaluated and will be given credit.
- v. For every MCQ, the correct alternative (A), (B), (C) or (D) in front of sub-question number is to be written as an answer.
- vi. Draw proper figures for answers wherever necessary.
- vii. The marks of construction should be clear and distinct. Do not erase them.
- viii. Diagram is essential for writing the proof of the theorem.

**Q.1. A. Four alternative answers are given for every sub-question. Select the *correct* alternative and write the alphabet of that answer:** [4]

- i. Out of the following which is the Pythagorean triplet?  
(A) (1, 5, 10) (B) (3, 4, 5) (C) (2, 2, 2) (D) (5, 5, 2)
- ii. Two circles of radii 5.5 cm and 3.3 cm respectively touch each other externally. What is the distance between their centres?  
(A) 4.4 cm (B) 2.2 cm (C) 8.8 cm (D) 8.9 cm
- iii. Distance of point (-3, 4) from the origin is \_\_\_\_\_.  
(A) 7 (B) 1 (C) -5 (D) 5
- iv. Find the volume of a cube of side 3 cm:  
(A) 27 cm<sup>3</sup> (B) 9 cm<sup>3</sup> (C) 81 cm<sup>3</sup> (D) 3 cm<sup>3</sup>

**B. Solve the following questions:** [4]

- i. The ratio of corresponding sides of similar triangles is 3 : 5, then find the ratio of their areas.
- ii. Find the diagonal of a square whose side is 10 cm.
- iii. □ABCD is cyclic. If  $\angle B = 110^\circ$ , then find measure of  $\angle D$ .
- iv. Find the slope of the line passing through the points A(2, 3) and B(4, 7).

**Q.2. A. Complete and write the following activities (Any two):** [4]

i.

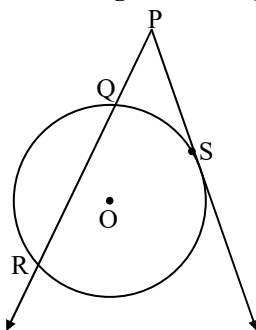

In the figure given above, 'O' is the centre of the circle, seg PS is a tangent segment and S is the point of contact. Line PR is a secant.

If  $PQ = 3.6$ ,  $QR = 6.4$ , find PS.

**Solution:**

$$PS^2 = PQ \times \square$$

...(tangent secant segments theorem)

$$= PQ \times (PQ \times \square)$$



$$= 3.6 \times (3.6 + 6.4)$$

$$= 3.6 \times \square$$

$$= 36$$

$$\therefore PS = \square$$

...(by taking square roots)

ii. If  $\sec \theta = \frac{25}{7}$ , find the value of  $\tan \theta$ .

**Solution:**

$$1 + \tan^2 \theta = \sec^2 \theta$$

$$\therefore 1 + \tan^2 \theta = \left(\frac{25}{7}\right)^2$$

$$\therefore \tan^2 \theta = \frac{625}{49} - \square$$

$$= \frac{625 - 49}{49}$$

$$= \frac{\square}{49}$$

$$\therefore \tan \theta = \frac{\square}{7}$$

...(by taking square roots)

iii.

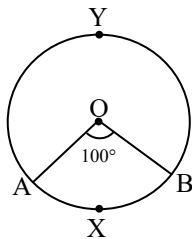

In the figure given above, O is the centre of the circle. Using given information complete the following table:

Type of arc	Name of the arc	Measure of the arc
Minor arc	<input type="text"/>	<input type="text"/>
Major arc	<input type="text"/>	<input type="text"/>

**B. Solve the following sub-questions (Any four):**

[8]

i.

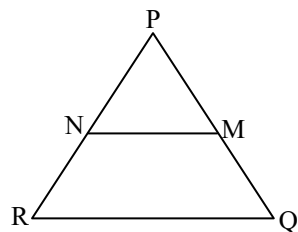

In  $\Delta PQR$ ,  $NM \parallel RQ$ . If  $PM = 15$ ,  $MQ = 10$ ,  $NR = 8$ , then find  $PN$ .

ii.

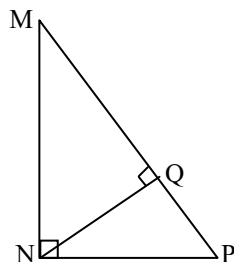

In  $\Delta MNP$ ,  $\angle MNP = 90^\circ$ ,  $\text{seg } NQ \perp \text{seg } MP$ . If  $MQ = 9$ ,  $QP = 4$ , then find  $NQ$ .



iii.

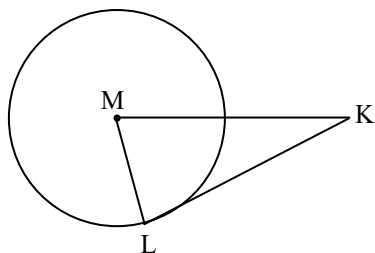

In the figure given above, M is the centre of the circle and seg KL is a tangent segment. L is a point of contact. If  $MK = 12$ ,  $KL = 6\sqrt{3}$ , then find the radius of the circle.

iv. Find the co-ordinates of midpoint of the segment joining the points (22, 20) and (0, 16).

v. A person is standing at a distance of 80 metres from a Church and looking at its top. The angle of elevation is of  $45^\circ$ . Find the height of the Church.

Q.3. A. Complete and write the following activities (Any one):

[3]

i.

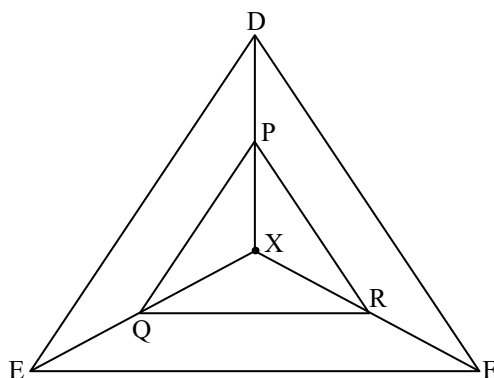

In the given figure, X is any point in the interior of the triangle. Point X is joined to the vertices of triangle. seg PQ  $\parallel$  seg DE, seg QR  $\parallel$  seg EF. Complete the activity and prove that seg PR  $\parallel$  seg DF.

**Proof:**

In  $\triangle XDE$ ,  
PQ  $\parallel$  DE ... (Given)

$$\therefore \frac{XP}{PD} = \frac{QE}{QE} \quad \dots \text{(Basic proportionality theorem)...(i)}$$

In  $\triangle XEF$ ,  
QR  $\parallel$  EF ... (Given)

$$\therefore \frac{XQ}{QE} = \frac{XR}{RF} \quad \dots \text{( )... (ii)}$$

$$\therefore \frac{XP}{PD} = \frac{XR}{RF} \quad \dots \text{[From (i) and (ii)]}$$

$\therefore$  seg PR  $\parallel$  seg DF ... (By converse of basic proportionality theorem)

ii. If A(6, 1), B(8, 2), C(9, 4) and D(7, 3) are the vertices of  $\square ABCD$ , show that  $\square ABCD$  is a parallelogram.**Solution:**

$$\text{Slope of line } = \frac{y_2 - y_1}{x_2 - x_1}$$

$$\therefore \text{Slope of line AB} = \frac{2-1}{8-6} = \frac{1}{2} \quad \dots \text{(i)}$$

$$\therefore \text{Slope of line BC} = \frac{4-2}{9-8} = 2 \quad \dots \text{(ii)}$$

$$\therefore \text{Slope of line CD} = \frac{3-4}{7-9} = \frac{1}{2} \quad \dots \text{(iii)}$$



- $\therefore$  Slope of line DA =  $\frac{3-1}{7-6} = \square$  ... (iv)
- $\therefore$  Slope of line AB =  $\square$  ... [From (i) and (iii)]
- $\therefore$  line AB  $\parallel$  line CD
- $\therefore$  Slope of line BC =  $\square$  ... [From (ii) and (iv)]
- $\therefore$  line BC  $\parallel$  line DA

Both the pairs of opposite sides of the quadrilateral are parallel.

$\therefore$   $\square$ ABCD is a parallelogram.

**B. Solve the following sub-questions (Any two):**

[6]

- i. If  $\Delta$ PQR, point S is the mid-point of side QR. If PQ = 11, PR = 17, PS = 13, find QR.
- ii. Prove that, tangent segments drawn from an external point to the circle are congruent.
- iii. Draw a circle with radius 4.1 cm. Construct tangents to the circle from a point at a distance 7.3 cm from the centre.
- iv. A metal cuboid of measures 16 cm  $\times$  11 cm  $\times$  10 cm was melted to make coins. How many coins were made, if the thickness and diameter of each coin was 2 mm and 2 cm respectively? ( $\pi = 3.14$ )

**Q.4. Solve the following sub-questions (Any two):**

[8]

- i. In  $\Delta$ ABC, PQ is a line segment intersecting AB at P and AC at Q such that seg PQ  $\parallel$  seg BC. If PQ divides  $\Delta$ ABC into two equal parts having equal areas, find  $\frac{BP}{AB}$ .
- ii. Draw a circle of radius 2.7 cm and draw a chord PQ of length 4.5 cm. Draw tangents at points P and Q without using centre.

iii.

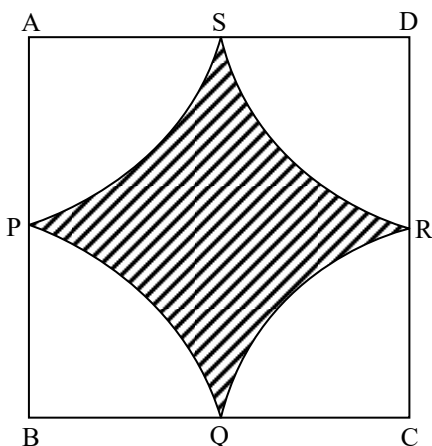

In the figure given above  $\square$ ABCD is a square of side 50 m. Points P, Q, R, S are midpoints of side AB, side BC, side CD, side AD respectively. Find area of shaded region.

**Q.5. Solve the following sub-questions (Any one):**

[3]

- i. Circles with centres A, B and C touch each other externally. If AB = 3 cm, BC = 3 cm, CA = 4 cm, then find the radii of each circle.
- ii. If  $\sin \theta + \sin^2 \theta = 1$   
show that:  $\cos^2 \theta + \cos^4 \theta = 1$

**BOARD QUESTION PAPER: JULY 2020****Maths - II****Time: 2 Hours****Max. Marks: 40****Notes:**

- i. All questions are compulsory.
- ii. Use of calculator is not allowed.
- iii. The numbers to the right of the questions indicate full marks.
- iv. In case of MCQ's [Q. No. 1(A)] only the first attempt will be evaluated and will be given credit.
- v. For every MCQ, the correct alternative (A), (B), (C) or (D) with sub-question number is to be written as an answer.
- vi. Draw proper figures for answers wherever necessary.
- vii. The marks of construction should be clear. Do not erase them.
- viii. Diagram is essential for writing the proof of the theorem.

**Q.1. (A) For each of the following sub-question four alternative answers are given. Choose the correct alternative and write its alphabet:**

**[4]**

1.  $\triangle ABC \sim \triangle PQR$  and  $\angle A = 45^\circ$ ,  $\angle Q = 87^\circ$ , then  $\angle C =$  \_\_\_\_\_.  
(A)  $45^\circ$  (B)  $87^\circ$  (C)  $48^\circ$  (D)  $90^\circ$
2.  $\angle PRQ$  is inscribed in the arc  $PRQ$  of a circle with centre 'O'.  
If  $\angle PRQ = 75^\circ$ , then  $m(\text{arc } PRQ) =$  \_\_\_\_\_.  
(A)  $75^\circ$  (B)  $150^\circ$  (C)  $285^\circ$  (D)  $210^\circ$
3. A line makes an angle of  $60^\circ$  with the positive direction of X-axis, so the slope of a line is \_\_\_\_\_.  
(A)  $\frac{1}{2}$  (B)  $\frac{\sqrt{3}}{2}$  (C)  $\sqrt{3}$  (D)  $\frac{1}{\sqrt{3}}$
4. Radius of a sector of a circle is 5 cm and length of arc is 10 cm, then the area of a sector is \_\_\_\_\_.  
(A)  $50 \text{ cm}^2$  (B)  $25 \text{ cm}^2$  (C)  $25 \text{ m}^2$  (D)  $10 \text{ cm}^2$

**(B) Solve the following sub-questions:**

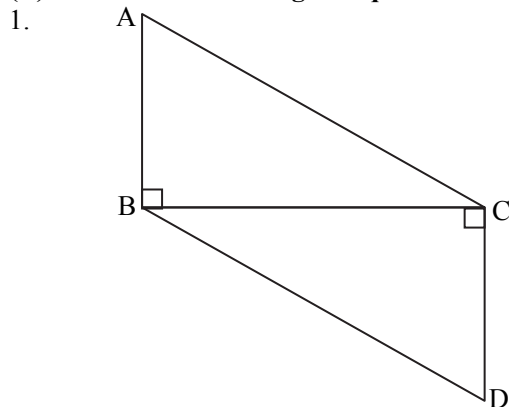
**[4]**

In the above figure, seg  $AB \perp$  seg  $BC$  and seg  $DC \perp$  seg  $BC$ .

If  $AB = 3 \text{ cm}$  and  $CD = 4 \text{ cm}$ , then find  $\frac{A(\triangle ABC)}{A(\triangle DCB)}$ .

2. In cyclic  $\square ABCD$ ,  $\angle B = 75^\circ$ , then find  $\angle D$ .
3. Point A, B, C are collinear. If slope of line AB is  $-\frac{1}{2}$ , then find the slope of line BC.
4. If  $3 \sin \theta = 4 \cos \theta$ , then find the value of  $\tan \theta$ .



Q.2. (A) Complete the following activities and rewrite it (Any two):

[4]

1.

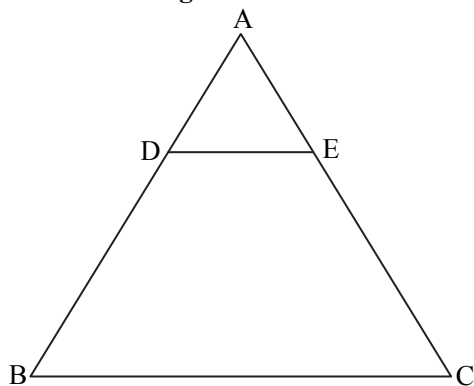

In  $\triangle ABC$ , seg  $DE \parallel$  side  $BC$ . If  $AD = 6$  cm,  $DB = 9$  cm,  $EC = 7.5$  cm, then complete the following activity to find  $AE$ .

**Activity:** In  $\triangle ABC$ , seg  $DE \parallel$  side  $BC$  ..... (given)

$$\therefore \frac{AD}{DB} = \frac{AE}{EC} \dots\dots \square$$

$$\therefore \frac{6}{9} = \frac{AE}{\square}$$

$$\therefore AE = \frac{6 \times 7.5}{\square}$$

$$\therefore AE = \square$$

2.

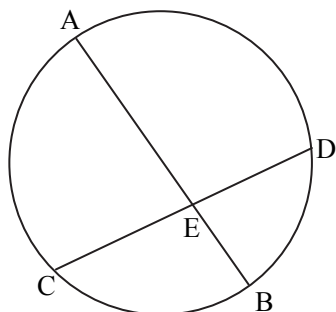

In the above figure, chord  $AB$  and chord  $CD$  intersect each other at point  $E$ . If  $AE = 15$ ,  $EB = 6$ ,  $CE = 12$ , then complete the activity to find  $ED$ .

**Activity:**

Chord  $AB$  and chord  $CD$  intersect each other at point  $E$  ..... (given)

$$\therefore CE \times ED = AE \times EB \dots\dots \square$$

$$\therefore \square \times ED = 15 \times 6$$

$$\therefore ED = \frac{\square}{12}$$

$$\therefore ED = \square$$

3. If  $C(3, 5)$  and  $D(-2, -3)$ , then complete the following activity to find the distance between points  $C$  and  $D$ .

**Activity:**

Let  $C(3, 5) \equiv (x_1, y_1)$ ,  $D(-2, -3) \equiv (x_2, y_2)$

$$CD = \sqrt{(x_2 - \square)^2 + (y_2 - y_1)^2} \dots\dots \text{(formula)}$$

$$\therefore CD = \sqrt{(-2 - \square)^2 + (-3 - 5)^2}$$



$$\therefore CD = \sqrt{\square + 64}$$

$$\therefore CD = \sqrt{\square}$$

**B. Solve the following sub-questions (Any four):****[8]**

- $\triangle ABC \sim \triangle PQR$ ,  $A(\triangle ABC) = 81 \text{ cm}^2$ ,  $A(\triangle PQR) = 121 \text{ cm}^2$ .  
If  $BC = 6.3 \text{ cm}$ , then find  $QR$ .
- In  $\triangle PQR$ ,  $\angle P = 60^\circ$ ,  $\angle Q = 90^\circ$  and  $QR = 6\sqrt{3} \text{ cm}$ , then find the values of  $PR$  and  $PQ$ .
- Find the slope of a line passing through the points  $A(2, 5)$  and  $B(4, -1)$ .
- Draw a circle with centre 'O' and radius 3.2 cm. Draw a tangent to the circle at any point P on it.
- Find the surface area of a sphere of radius 7 cm.

**Q.3. A. Complete the following activities and rewrite it (Any one):****[3]**

1.

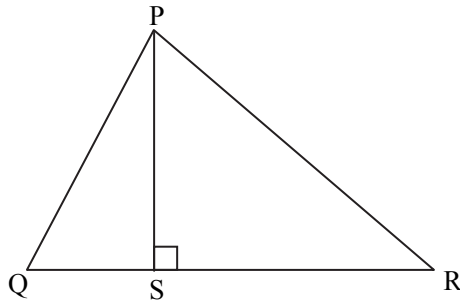

In  $\triangle PQR$ , seg  $PS \perp$  side  $QR$ , then complete the activity to prove  $PQ^2 + RS^2 = PR^2 + QS^2$ .

**Activity:**

In  $\triangle PSQ$ ,  $\angle PSQ = 90^\circ$

$$\therefore PS^2 + QS^2 = PQ^2 \dots\dots \text{(Pythagoras theorem)}$$

$$\therefore PS^2 = PQ^2 - \square \dots\dots \text{(I)}$$

Similarly,

In  $\triangle PSR$ ,  $\angle PSR = 90^\circ$

$$\therefore PS^2 + \square = PR^2 \dots\dots \text{(Pythagoras theorem)}$$

$$\therefore PS^2 = PR^2 - \square \dots\dots \text{(II)}$$

$$\therefore PQ^2 - \square = \square - RS^2 \dots\dots \text{from (I) and (II)}$$

$$\therefore PQ^2 + \square = PR^2 + QS^2$$

- Measure of arc of a circle is  $36^\circ$  and its length is 176 cm. Then complete the following activity to find the radius of circle.

**Activity:**

Here, measure of arc  $= \theta = 36^\circ$

Length of arc  $= l = 176 \text{ cm}$

$$\therefore \text{Length of arc } (l) = \frac{\theta}{360} \times \square \dots\dots \text{(formula)}$$

$$\therefore \square = \frac{36}{360} \times 2 \times \frac{22}{7} \times r$$

$$\therefore 176 = \frac{1}{\square} \times \frac{44}{7} \times r$$

$$\therefore r = \frac{176 \times \square}{44}$$

$$\therefore r = \square \times 70$$

Radius of circle (r) =  $\square$  cm



**B. Solve the following sub-questions (Any two):**

[6]

1. Prove that, “The ratio of the intercepts made on a transversal by three parallel lines is equal to the ratio of the corresponding intercepts made on any other transversal by the same parallel lines.”
2. Draw a circle with centre ‘O’ and radius 3.4 cm. Draw a chord MN of length 5.7 cm in it. Construct tangents at points M and N to the circle.
3. Prove that:  

$$\frac{1}{\sec\theta - \tan\theta} = \sec\theta + \tan\theta.$$
4. Radii of the top and base of frustum are 14 cm and 8 cm respectively. Its height is 8 cm. Find its curved surface area. ( $\pi = 3.14$ )

**Q.4. Solve the following sub-questions (Any two):**

[8]

1.

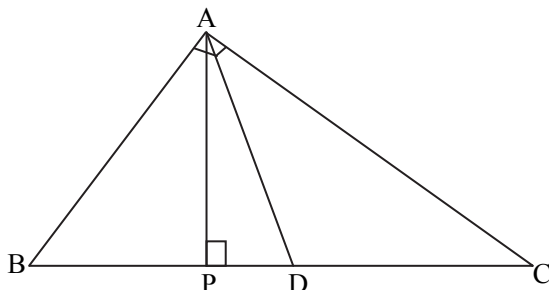

In  $\triangle ABC$ ,  $\angle BAC = 90^\circ$ , seg  $AP \perp$  side  $BC$ ,  $B-P-C$ . Point  $D$  is the mid-point of side  $BC$ , then prove that  $2AD^2 = BD^2 + CD^2$ .

2.

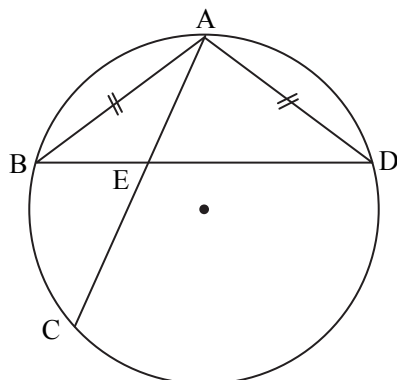

In the above figure, chord  $AB \cong$  chord  $AD$ . Chord  $AC$  and chord  $BD$  intersect each other at point  $E$ . Then prove that:  
 $AB^2 = AE \times AC$ .

3. A straight road leads to the foot of the tower of height 48 m. From the top of the tower the angles of depression of two cars standing on the road are  $30^\circ$  and  $60^\circ$  respectively. Find the distance between the two cars. ( $\sqrt{3} = 1.73$ )

**Q.5. Solve the following sub-questions (Any one):**

[3]

- i. Let  $M$  be a point of contact of two internally touching circles. Let line  $AMB$  be their common tangent. The chord  $CD$  of the bigger circle touches the smaller circle at point  $N$ . The chord  $CM$  and chord  $DM$  of bigger circle intersect the smaller circle at point  $P$  and  $R$  respectively.
  - a. From the above information draw the suitable figure.
  - b. Draw seg  $NR$  and seg  $NM$  and write the two pairs of congruent angles in smaller circle considering tangent and chord.
  - c. By using the property which is used in (b) write the two pairs of congruent angles in the bigger circle.
- ii. Draw a circle with centre ‘O’ and radius 3 cm. Draw a tangent segment  $PA$  having length  $\sqrt{40}$  cm from an exterior point  $P$ .

**BOARD QUESTION PAPER: July 2019****Maths Part - II****Time: 2 Hours****Max. Marks: 40****Note:**

- i. All questions are compulsory.
- ii. Use of calculator is not allowed.
- iii. Figures to the right of questions indicate full marks.
- iv. Draw proper figures for answers wherever necessary.
- v. The marks of construction should be clear and distinct. Do not erase them.
- vi. While writing any proof, drawing relevant figure is necessary. Also the proof should be consistent with the figure.

**1. (A) Solve the following questions (Any four):****[4]**

- i. Point M is the mid-point of segment AB. If  $AB = 8.6$  cm, then find AM.
- ii. Write the equations of  $x$ -axis and  $y$ -axis.
- iii.

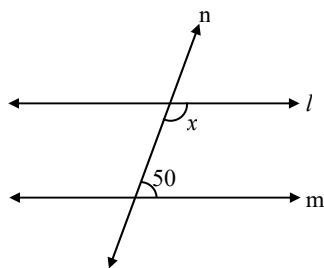

In the above figure, line  $l \parallel$  line  $m$  and line  $n$  is a transversal. Using the given information find the value of  $x$ .

- iv. If  $\sin \theta = \frac{1}{2}$ , then find the value of  $\theta$ .
- v. If the side of a cube is 5 cm, then find its volume.
- vi. In  $\Delta DEF$ , if  $\angle E = 90^\circ$ , then find the value of  $\angle D + \angle F$ .

**(B) Solve the following questions (Any two):****[4]**

- i. Draw seg  $AB = 6.8$  cm and draw perpendicular bisector of it.
- ii. If  $\Delta ABC \sim \Delta DEF$ , then write the corresponding congruent angles and also write the ratio of corresponding sides.
- iii. Perpendicular height of a cone is 12 cm and its slant height is 13 cm. Find the radius of the base of cone.

**2. (A) Choose the correct alternative:****[4]**

- i. In right-angled triangle PQR, if hypotenuse  $PR = 12$  and  $PQ = 6$ , then what is the measure of  $\angle P$ ?  
(A)  $30^\circ$                       (B)  $60^\circ$                       (C)  $90^\circ$                       (D)  $45^\circ$
- ii. If  $\Delta ABC \sim \Delta PQR$  and  $4A(\Delta ABC) = 25A(\Delta PQR)$ , then  $AB : PQ = ?$   
(A)  $4 : 25$                       (B)  $2 : 5$                       (C)  $5 : 2$                       (D)  $25 : 4$



- iii. If the points, A, B, C are non-collinear points, then how many circles can be drawn which passes through points A, B and C ?  
 (A) two (B) three (C) one (D) infinite

- iv.  $\sin \theta \times \operatorname{cosec} \theta = ?$   
 (A)  $\sqrt{2}$  (B)  $\frac{1}{2}$  (C) 0 (D) 1

**(B) Solve the following questions (Any two):**

[4]

- i. Construct a tangent to a circle with centre O and radius 3.5 cm at a point P on it.
- ii. Find the slope of the line passing through the points A(4, 7) and B(2, 3).
- iii. If the length of an arc of sector of a circle is 20 cm and if radius is 7 cm, find the area of the sector.

**3. (A) Complete the following activities (Any two):**

[4]

i.

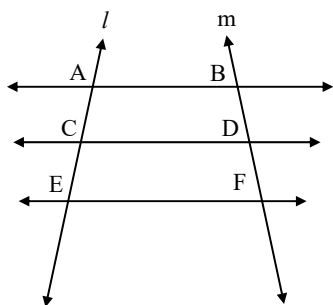

In the above figure, line AB  $\parallel$  line CD  $\parallel$  line EF, line  $l$  and line  $m$  are its transversals. If AC = 6, CE = 9. BD = 8, then complete the following activity to find DF.

**Activity:**

$$\frac{AC}{\square} = \frac{\square}{DF} \text{ (Property of three parallel lines and their transversal)}$$

$\therefore \frac{6}{9} = \frac{\square}{DF}$

$\therefore DF = \square$

ii.

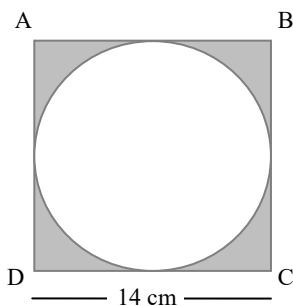

A circle is inscribed in square ABCD of side 14 cm. Complete the following activity to find the area of shaded portion.

**Activity:**

$$\begin{aligned} \text{Area of square ABCD} &= \square \\ &= 14^2 \\ &= 196 \text{ cm}^2 \end{aligned}$$



$$\begin{aligned} \text{Area of circle} &= \pi r^2 \\ &= \frac{22}{7} \times 7^2 \\ &= \square \text{ cm}^2 \end{aligned}$$

$$\begin{aligned} \text{Area of shaded portion} &= \text{Area of square ABCD} - \text{Area of circle} \\ &= 196 - \square \\ &= \square \text{ cm}^2 \end{aligned}$$

- iii. In the following figure, O is the centre of the circle.  $\angle ABC$  is inscribed in arc ABC and  $\angle ABC = 65^\circ$ . Complete the following activity to find the measure of  $\angle AOC$ .

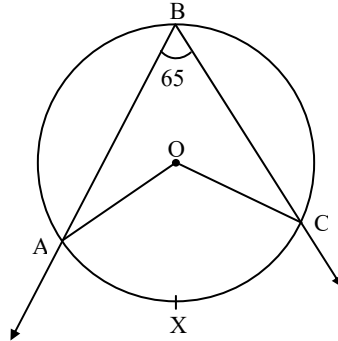

$$\angle ABC = \frac{1}{2} m \square \text{ (Inscribed angle theorem)}$$

$$\square \times 2 = m(\text{arc AXC})$$

$$m(\text{arc AXC}) = \square$$

$$\angle AOC = m(\text{arc AXC}) \text{ (Definition of measure of an arc)}$$

$$\angle AOC = \square$$

**(B) Solve the following questions (Any two):**

[4]

- Find the side and perimeter of a square whose diagonal is  $13\sqrt{2}$  cm.
- Find the co-ordinates of the centroid of the  $\Delta PQR$ , whose vertices are  $P(3, -5)$ ,  $Q(4, 3)$  and  $R(11, -4)$
- If  $\cos \theta = \frac{5}{13}$ , then find  $\sin \theta$ .

**4. Solve the following questions (Any three):**

[9]

- Verify that the points  $A(-2, 2)$ ,  $B(2, 2)$  and  $C(2, 7)$  are the vertices of right-angled triangle.
- Prove that:  $\sqrt{\frac{1-\sin \theta}{1+\sin \theta}} = \sec \theta - \tan \theta$
- In  $\Delta ABC$ , seg AP is a median. If  $BC = 18$ ,  $AB^2 + AC^2 = 260$ , then find the length of AP.
- $\Delta ABC \sim \Delta LMN$ . In  $\Delta ABC$ ,  $AB = 5.5$  cm,  $BC = 6$  cm,  $CA = 4.5$  cm. If  $MN = 4.8$  cm, then construct  $\Delta ABC$  and  $\Delta LMN$ .

**5. Solve the following questions (Any one):**

[4]

i.

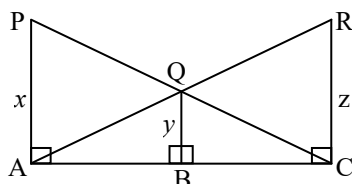



In the above figure, seg PA, seg QB and RC are perpendicular to seg AC. From the information given in the figure, prove that:  $\frac{1}{x} + \frac{1}{z} = \frac{1}{y}$ .

ii.

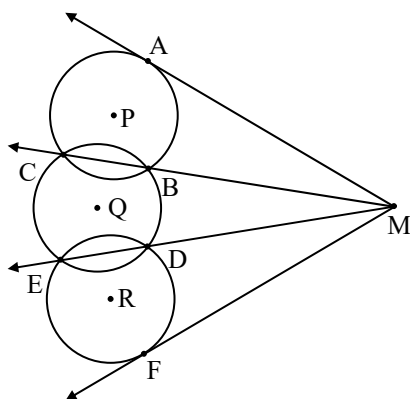

In the above figure, the circles with P, Q and R intersect at points B, C, D and E as shown. Lines CB and ED intersect in point M. Lines drawn from point M touch the circles at points A and F. Prove that  $MA = MF$ .

6. Solve the following questions (Any one):

[3]

i.

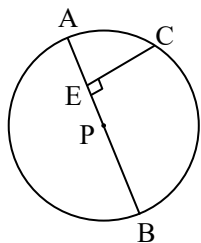

In the above figure, seg AB is a diameter of a circle with centre P. C is any point on the circle. seg  $CE \perp$  seg AB. Prove that CE is the geometric mean of AE and EB. Write the proof with the help of following steps:

- Draw ray CE. It intersects the circle at D.
- Show that  $CE = ED$ .
- Write the result using theorem of intersection of chords inside a circle.
- Using  $CE = ED$ , complete the proof.

ii.

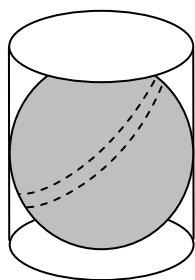

In the above figure, a sphere is placed in a cylinder. It touches the top, bottom and the curved surface of the cylinder. If radius of the base of cylinder is 'r', write the answer of the following questions.

- What is the height of the cylinder in terms of 'r'?
- What is the ratio of the curved surface area of the cylinder and the surface area of the sphere?
- What is the ratio of volumes of the cylinder and of the sphere?



# BOARD QUESTION PAPER: MARCH 2019

## MATHS (PART - II)

Time: 2 Hours

Max. Marks: 40

**Note:**

- i. All questions are compulsory.
- ii. Use of calculator is not allowed.
- iii. Figures to the right of questions indicate full marks.
- iv. Draw proper figures for answers wherever necessary.
- v. The marks of construction should be clear and distinct. Do not erase them.
- vi. While writing any proof, drawing relevant figure is necessary. Also the proof should be consistent with the figure.

1. (A) Solve the following questions (Any four): [4]

- i. If  $\triangle ABC \sim \triangle PQR$  and  $\angle A = 60^\circ$ , then  $\angle P = ?$
- ii. In right-angled  $\triangle ABC$ , if  $\angle B = 90^\circ$ ,  $AB = 6$ ,  $BC = 8$ , then find  $AC$ .
- iii. Write the length of largest chord of a circle with radius 3.2 cm.
- iv. From the given number line, find  $d(A, B)$ :

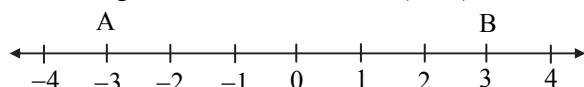

- v. Find the value of  $\sin 30^\circ + \cos 60^\circ$ .
- vi. Find the area of a circle of radius 7 cm.

(B) Solve the following questions (Any two): [4]

- i. Draw seg  $AB$  of length 5.7 cm and bisect it.
- ii. In right-angled triangle  $PQR$ , if  $\angle P = 60^\circ$ ,  $\angle R = 30^\circ$  and  $PR = 12$ , then find the values of  $PQ$  and  $QR$ .
- iii. In a right circular cone, if perpendicular height is 12 cm and radius is 5 cm, then find its slant height.

2. (A) Choose the correct alternative: [4]

- i.  $\triangle ABC$  and  $\triangle DEF$  are equilateral triangles. If  $A(\triangle ABC) : A(\triangle DEF) = 1 : 2$  and  $AB = 4$ , then what is the length of  $DE$ ?  
 (A)  $2\sqrt{2}$       (B) 4      (C) 8      (D)  $4\sqrt{2}$
- ii. Out of the following which is a Pythagorean triplet?  
 (A) (5, 12, 14)    (B) (3, 4, 2)      (C) (8, 15, 17)    (D) (5, 5, 2)
- iii.  $\angle ACB$  is inscribed in arc  $ACB$  of a circle with centre  $O$ . If  $\angle ACB = 65^\circ$ , find  $m(\text{arc } ACB)$  :  
 (A)  $130^\circ$       (B)  $295^\circ$       (C)  $230^\circ$       (D)  $65^\circ$
- iv.  $1 + \tan^2 \theta = ?$   
 (A)  $\sin^2 \theta$       (B)  $\sec^2 \theta$       (C)  $\operatorname{cosec}^2 \theta$     (D)  $\cot^2 \theta$

(B) Solve the following questions (Any two): [4]

- i. Construct tangent to a circle with centre  $A$  and radius 3.4 cm at any point  $P$  on it.
- ii. Find slope of a line passing through the points  $A(3, 1)$  and  $B(5, 3)$ .
- iii. Find the surface area of a sphere of radius 3.5 cm.



## 3. (A) Complete the following activities (Any two):

i.

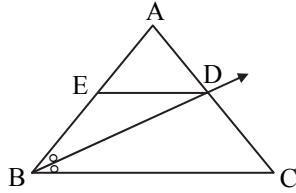
In  $\triangle ABC$ , ray  $BD$  bisects  $\angle ABC$ .If  $A-D-C$ ,  $A-E-B$  and  $\text{seg } ED \parallel \text{side } BC$ , then prove that:  $\frac{AB}{BC} = \frac{AE}{EB}$ .**Proof:**In  $\triangle ABC$ , ray  $BD$  is bisector of  $\angle ABC$ .

$$\therefore \frac{AB}{BC} = \frac{AD}{DC} \quad \dots \text{(i) (By angle bisector theorem)}$$

In  $\triangle ABC$ ,  $\text{seg } DE \parallel \text{side } BC$ 

$$\therefore \frac{AE}{EB} = \frac{AD}{DC} \quad \dots \text{(ii) } \boxed{\phantom{000}}$$

$$\therefore \frac{AB}{BC} = \frac{AE}{EB} \quad \dots \text{[From (i) and (ii)]}$$

ii.

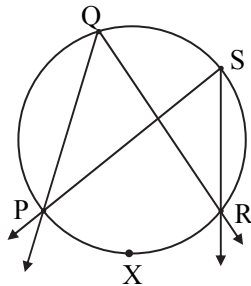

Prove that, angles inscribed in the same arc are congruent.

**Given:**  $\angle PQR$  and  $\angle PSR$  are inscribed in the same arc.  
Arc  $PXR$  is intercepted by the angles.**To prove:**  $\angle PQR \cong \angle PSR$ **Proof:**

$$m\angle PQR = \frac{1}{2} m(\text{arc } PXR) \quad \dots \text{(i) } \boxed{\phantom{000}}$$

$$m\angle \boxed{\phantom{000}} = \frac{1}{2} m(\text{arc } PXR) \quad \dots \text{(ii) } \boxed{\phantom{000}}$$

$$\therefore m\angle \boxed{\phantom{000}} = m\angle PSR \quad \dots \text{[From (i) and (ii)]}$$

$$\therefore \angle PQR \cong \angle PSR \quad \dots \text{(Angles equal in measure are congruent)}$$

iii. How many solid cylinders of radius 6 cm and height 12 cm can be made by melting a solid sphere of radius 18 cm?

**Activity:** Radius of the sphere,  $r = 18$  cmFor cylinder, radius  $R = 6$  cm, height  $H = 12$  cm

$$\therefore \text{Number of cylinders can be made} = \frac{\text{Volume of the sphere}}{\boxed{\phantom{000}}}$$

$$= \frac{4}{3} \pi r^3$$

$$= \frac{4}{3} \times 18 \times 18 \times 18$$

$$= \boxed{\phantom{000}}$$



**(B) Solve the following questions (Any two):**

[4]

i.

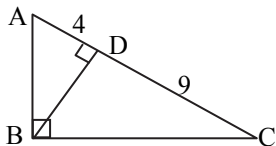

In right-angled  $\triangle ABC$ ,  $BD \perp AC$ .

If  $AD = 4$ ,  $DC = 9$ , then find  $BD$ .

ii. Verify whether the following points are collinear or not:

$A(1, -3)$ ,  $B(2, -5)$ ,  $C(-4, 7)$ .

iii. If  $\sec \theta = \frac{25}{7}$ , then find the value of  $\tan \theta$ .

**4. Solve the following questions (Any three):**

[9]

i. In  $\triangle PQR$ , seg  $PM$  is a median,  $PM = 9$  and  $PQ^2 + PR^2 = 290$ . Find the length of  $QR$ .

ii.

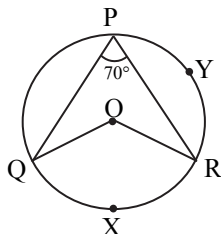

In the given figure,  $O$  is centre of circle.  $\angle QPR = 70^\circ$  and  $m(\text{arc } PYR) = 160^\circ$ , then find the value of each of the following:

(a)  $m(\text{arc } QXR)$

(b)  $\angle QOR$

(c)  $\angle PQR$

iii. Draw a circle with radius 4.2 cm. Construct tangents to the circle from a point at a distance of 7 cm from the centre.

iv. When an observer at a distance of 12 m from a tree looks at the top of the tree, the angle of elevation is  $60^\circ$ . What is the height of the tree? ( $\sqrt{3} = 1.73$ )

**5. Solve the following questions (Any one):**

[4]

i.

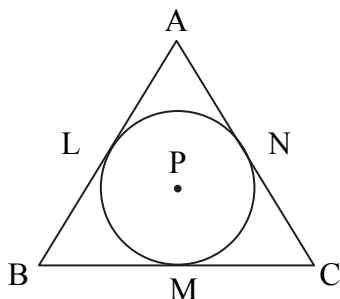

A circle with centre  $P$  is inscribed in the  $\triangle ABC$ . Side  $AB$ , side  $BC$  and side  $AC$  touch the circle at points  $L$ ,  $M$  and  $N$  respectively. Radius of the circle is  $r$ .

Prove that:  $A(\triangle ABC) = \frac{1}{2} (AB + BC + AC) \times r$ .

ii.

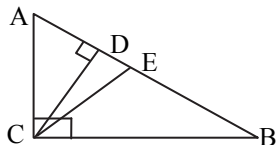

In  $\triangle ABC$ ,  $\angle ACB = 90^\circ$ . seg  $CD \perp$  side  $AB$  and seg  $CE$  is angle bisector of  $\angle ACB$ .

Prove that:  $\frac{AD}{BD} = \frac{AE^2}{BE^2}$ .



6. Solve the following questions (Any one):

[3]

- i. Show that the points  $(2, 0)$ ,  $(-2, 0)$  and  $(0, 2)$  are the vertices of a triangle. Also state with reason the type of the triangle.
- ii.

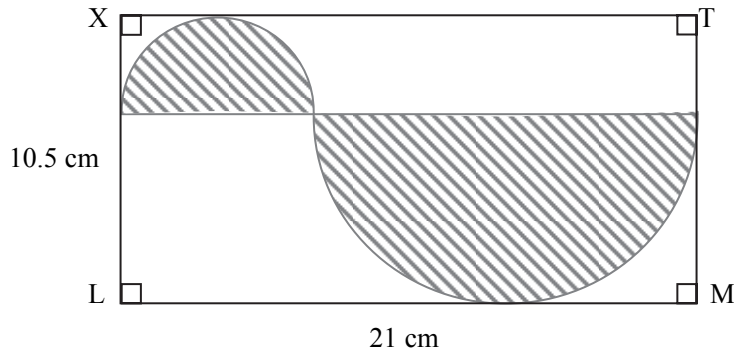

In the above figure,  $\square XLMT$  is a rectangle.  $LM = 21$  cm,  $XL = 10.5$  cm. Diameter of the smaller semicircle is half the diameter of the larger semicircle. Find the area of non-shaded region.