

# MATHEMATICS

## QUESTION BANK

*for*

## CLASS – X (TERM-II)

**CHAPTER WISE COVERAGE IN THE FORM  
MCQ WORKSHEETS AND PRACTICE QUESTIONS**

Prepared by

***M. S. KUMARSWAMY, TGT(MATHS)***

***M. Sc. Gold Medallist (Elect.), B. Ed.***

**Kendriya Vidyalaya GaCHIBOWLI**

ISAMPAL  
DEPUTY COMMISSIONER



केन्द्रीय विद्यालय संगठन, क्षेत्रीय कार्यालय,  
के. कामराज मार्ग, बेंगलूर-560 042  
KENDRIYA VIDYALAYA SANGATHAN  
REGIONAL OFFICE  
K. KAMARAJA ROAD, BANGALORE- 560042

F. DO-DC./2013-KVS(BGR)

Dated:05.09.2013

Dear Shri M.S.Kumarswamy,

It has been brought to my notice the good work done by you with regard to making question bank and worksheets for classes VI to X in Mathematics. I am pleased to look at your good work. Mathematics is one discipline which unfortunately and wrongly perceived as a phobia. May be lack of motivation from teachers and inadequate study habits of students is responsible for this state of affairs. Your work in this regard assumes a great significance. I hope your own students as well as students of other Vidyalayas will benefit by your venture. You may mail the material to all the Kendriya Vidyalayas of the region for their benefit. Keep up the good work.

**May God bless!**

Yours sincerely,

(Isampal)

Shri M.S.Kumarswamy  
TGT (Maths)  
Kendriya Vidyalaya  
Donimalai

Copy to: the principals, Kendriya Vidyalayas, Bangalore Region with instructions to make use of the materials prepared by Mr. M.S.Kumarswamy being forwarded separately.

**DEDICATED**  
**TO**  
**MY FATHER**  
**LATE SHRI. M. S. MALLAYYA**

# CLASS X : CHAPTER - 4 QUADRATIC EQUATIONS

## IMPORTANT FORMULAS & CONCEPTS

### POLYNOMIALS

An algebraic expression of the form  $p(x) = a_0 + a_1x + a_2x^2 + a_3x^3 + \dots + a_nx^n$ , where  $a \neq 0$ , is called a polynomial in variable  $x$  of degree  $n$ .

Here,  $a_0, a_1, a_2, a_3, \dots, a_n$  are real numbers and each power of  $x$  is a non-negative integer.

e.g.  $3x^2 - 5x + 2$  is a polynomial of degree 2.

$3\sqrt{x} + 2$  is not a polynomial.

➤ If  $p(x)$  is a polynomial in  $x$ , the highest power of  $x$  in  $p(x)$  is called **the degree of the polynomial**  $p(x)$ . For example,  $4x + 2$  is a polynomial in the variable  $x$  of degree 1,  $2y^2 - 3y + 4$  is a polynomial in the variable  $y$  of degree 2,

- ❖ A polynomial of degree 0 is called a constant polynomial.
- ❖ A polynomial  $p(x) = ax + b$  of degree 1 is called a linear polynomial.
- ❖ A polynomial  $p(x) = ax^2 + bx + c$  of degree 2 is called a quadratic polynomial.
- ❖ A polynomial  $p(x) = ax^3 + bx^2 + cx + d$  of degree 3 is called a cubic polynomial.
- ❖ A polynomial  $p(x) = ax^4 + bx^3 + cx^2 + dx + e$  of degree 4 is called a bi-quadratic polynomial.

### QUADRATIC EQUATION

A polynomial  $p(x) = ax^2 + bx + c$  of degree 2 is called a quadratic polynomial, then  $p(x) = 0$  is known as quadratic equation.

e.g.  $2x^2 - 3x + 2 = 0$ ,  $x^2 + 5x + 6 = 0$  are quadratic equations.

### METHODS TO FIND THE SOLUTION OF QUADRATIC EQUATIONS

Three methods to find the solution of quadratic equation:

1. Factorisation method
2. Method of completing the square
3. Quadratic formula method

### FACTORISATION METHOD

Steps to find the solution of given quadratic equation by factorisation

- Firstly, write the given quadratic equation in standard form  $ax^2 + bx + c = 0$ .
- Find two numbers  $\alpha$  and  $\beta$  such that sum of  $\alpha$  and  $\beta$  is equal to  $b$  and product of  $\alpha$  and  $\beta$  is equal to  $ac$ .
- Write the middle term  $bx$  as  $\alpha x + \beta x$  and factorise it by splitting the middle term and let factors are  $(x + p)$  and  $(x + q)$  i.e.  $ax^2 + bx + c = 0 \Rightarrow (x + p)(x + q) = 0$
- Now equate each factor to zero and find the values of  $x$ .
- These values of  $x$  are the required roots/solutions of the given quadratic equation.

### METHOD OF COMPLETING THE SQUARE

Steps to find the solution of given quadratic equation by Method of completing the square:

- Firstly, write the given quadratic equation in standard form  $ax^2 + bx + c = 0$ .
- Make coefficient of  $x^2$  unity by dividing all by  $a$  then we get

$$x^2 + \frac{b}{a}x + \frac{c}{a} = 0$$

- Shift the constant on RHS and add square of half of the coefficient of x i.e.  $\left(\frac{b}{2a}\right)^2$  on both sides.

$$x^2 + \frac{b}{a}x = -\frac{c}{a} \Rightarrow x^2 + 2\left(\frac{b}{2a}\right)x + \left(\frac{b}{2a}\right)^2 = -\frac{c}{a} + \left(\frac{b}{2a}\right)^2$$

- Write LHS as the perfect square of a binomial expression and simplify RHS.

$$\left(x + \frac{b}{2a}\right)^2 = \frac{b^2 - 4ac}{4a^2}$$

- Take square root on both sides

$$x + \frac{b}{2a} = \pm \sqrt{\frac{b^2 - 4ac}{4a^2}}$$

- Find the value of x by shifting the constant term on RHS i.e.  $x = \pm \sqrt{\frac{b^2 - 4ac}{4a^2}} - \frac{b}{2a}$

### QUADRATIC FORMULA METHOD

Steps to find the solution of given quadratic equation by quadratic formula method:

- Firstly, write the given quadratic equation in standard form  $ax^2 + bx + c = 0$ .
- Write the values of a, b and c by comparing the given equation with standard form.
- Find discriminant  $D = b^2 - 4ac$ . If value of D is negative, then is no real solution i.e. solution does not exist. If value of  $D \geq 0$ , then solution exists follow the next step.
- Put the value of a, b and D in quadratic formula  $x = \frac{-b \pm \sqrt{D}}{2a}$  and get the required roots/solutions.

### NATURE OF ROOTS

The roots of the quadratic equation  $ax^2 + bx + c = 0$  by quadratic formula are given by

$$x = \frac{-b \pm \sqrt{b^2 - 4ac}}{2a} = \frac{-b \pm \sqrt{D}}{2a}$$

where  $D = b^2 - 4ac$  is called discriminant. The nature of roots depends upon the value of discriminant D. There are three cases –

#### Case – I

When  $D > 0$  i.e.  $b^2 - 4ac > 0$ , then the quadratic equation has two distinct roots.

$$\text{i.e. } x = \frac{-b + \sqrt{D}}{2a} \text{ and } \frac{-b - \sqrt{D}}{2a}$$

#### Case – II

When  $D = 0$ , then the quadratic equation has two equal real roots.

$$\text{i.e. } x = \frac{-b}{2a} \text{ and } \frac{-b}{2a}$$

#### Case – III

When  $D < 0$  then there is no real roots exist.

**MCQ WORKSHEET-I**  
**CLASS X: CHAPTER – 4**  
**QUADRATIC EQUATIONS**

1. The roots of the equation  $x^2 + 7x + 10 = 0$  are  
(a) 2 and 5      (b) -2 and 5      (c) -2 and -5      (d) 2 and -5
  2. If  $\alpha, \beta$  are the roots of the quadratic equation  $x^2 + x + 1 = 0$ , then  $\frac{1}{\alpha} + \frac{1}{\beta}$   
(a) 0      (b) 1      (c) -1      (d) none of these
  3. If the equation  $x^2 + 4x + k = 0$  has real and distinct roots then  
(a)  $k < 4$       (b)  $k > 4$       (c)  $k \leq 4$       (d)  $k \geq 4$
  4. If the equation  $x^2 - ax + 1 = 0$  has two distinct roots then  
(a)  $|a| = 2$       (b)  $|a| < 2$       (c)  $|a| > 2$       (d) none of these
  5. If the equation  $9x^2 + 6kx + 4 = 0$  has equal roots then the roots are both equal to  
(a)  $\pm \frac{2}{3}$       (b)  $\pm \frac{3}{2}$       (c) 0      (d)  $\pm 3$
  6. If the equation  $(a^2 + b^2)x^2 - 2b(a + c)x + b^2 + c^2 = 0$  has equal roots then  
(a)  $2b = a + c$       (b)  $b^2 = ac$       (c)  $b = \frac{2ac}{a + c}$       (d)  $b = ac$
  7. If the equation  $x^2 - bx + 1 = 0$  has two distinct roots then  
(a)  $-3 < b < 3$       (b)  $-2 < b < 2$       (c)  $b > 2$       (d)  $b < -2$
  8. If  $x = 1$  is a common root of the equations  $ax^2 + ax + 3 = 0$  and  $x^2 + x + b = 0$  then  $ab =$   
(a) 6      (b) 3      (c) -3      (d)  $\frac{7}{2}$
  9. If  $p$  and  $q$  are the roots of the equation  $x^2 - px + q = 0$ , then  
(a)  $p = 1, q = -2$       (b)  $p = -2, q = 0$       (c)  $b = 0, q = 1$       (d)  $p = -2, q = 1$
  10. If the equation  $ax^2 + bx + c = 0$  has equal roots then  $c =$   
(a)  $\frac{-b}{2a}$       (b)  $\frac{b}{2a}$       (c)  $\frac{-b^2}{4a}$       (d)  $\frac{b^2}{4a}$
  11. If the equation  $ax^2 + 2x + a = 0$  has two distinct roots if  
(a)  $a = \pm 1$       (b)  $a = 0$       (c)  $a = 0, 1$       (d)  $a = -1, 0$
  12. The possible value of  $k$  for which the equation  $x^2 + kx + 64 = 0$  and  $x^2 - 8x + k = 0$  will both have real roots, is  
(a) 4      (b) 8      (c) 12      (d) 16
- .....

**MCQ WORKSHEET-II**  
**CLASS X: CHAPTER – 4**  
**QUADRATIC EQUATIONS**

1. The value of  $\sqrt{6+\sqrt{6+\sqrt{6+\dots}}}$  is  
(a) 4            (b) 3            (c) -2            (d)  $\frac{7}{2}$
  2. If 2 is the root of the equation  $x^2 + bx + 12 = 0$  and the equation  $x^2 + bx + q = 0$  has equal roots then q =  
(a) 8            (b) 16            (c) -8            (d) -16
  3. If the equation  $(a^2 + b^2)x^2 - 2(ac + bd)x + c^2 + d^2 = 0$  has equal roots then  
(a)  $ab = cd$     (b)  $ad = bc$     (c)  $ad = \sqrt{bc}$     (d)  $ab = \sqrt{cd}$
  4. If a and b can take values 1, 2, 3, 4. Then the number of the equations of the form  $ax^2 + bx + c = 0$  having real roots is  
(a) 6            (b) 7            (c) 10            (d) 12
  5. The number of quadratic equations having real roots and which do not change by squaring their roots is  
(a) 4            (b) 3            (c) 2            (d) 1
  6. If one of the roots of the quadratic equation  $(k^2 + 4)x^2 + 13x + 4k$  is reciprocal of the other then k =  
(a) 2            (b) 1            (c) -1            (d) -2
  7. If  $\alpha, \beta$  are the roots of the quadratic equation  $4x^2 + 3x + 7 = 0$ , then  $\frac{1}{\alpha} + \frac{1}{\beta}$   
(a)  $\frac{7}{3}$             (b)  $-\frac{7}{3}$             (c)  $\frac{3}{7}$             (d)  $-\frac{3}{7}$
  8. If  $\alpha, \beta$  are the roots of the quadratic equation  $x^2 - p(x + 1) - c = 0$ , then  $(\alpha + 1)(\beta + 1) =$   
(a)  $c - 1$         (b)  $1 - c$         (c)  $c$             (d)  $1 + c$
  9. Find the values of k for which the quadratic equation  $2x^2 + kx + 3 = 0$  has real equal roots.  
(a)  $\pm 2\sqrt{6}$       (b)  $2\sqrt{6}$         (c) 0            (d)  $\pm 2$
  10. Find the values of k for which the quadratic equation  $kx(x - 3) + 9 = 0$  has real equal roots.  
(a)  $k = 0$  or  $k = 4$     (b)  $k = 1$  or  $k = 4$     (c)  $k = -3$  or  $k = 3$     (d)  $k = -4$  or  $k = 4$
  11. Find the values of k for which the quadratic equation  $4x^2 - 3kx + 1 = 0$  has real and equal roots.  
(a)  $\pm \frac{4}{3}$             (b)  $\pm \frac{2}{3}$             (c)  $\pm 2$             (d) none of these
  12. Find the values of k for which the quadratic equation  $(k - 12)x^2 + 2(k - 12)x + 2 = 0$  has real and equal roots.  
(a)  $k = 0$  or  $k = 14$     (b)  $k = 12$  or  $k = 24$     (c)  $k = 14$  or  $k = 12$     (d)  $k = 1$  or  $k = 12$
- .....

**MCQ WORKSHEET-III**  
**CLASS X: CHAPTER – 4**  
**QUADRATIC EQUATIONS**

1. The value of k for which equation  $9x^2 + 8kx + 8 = 0$  has equal roots is:  
(a) only 3                      (b) only -3      (c)  $\pm 3$                       (d) 9
  2. Which of the following is not a quadratic equation?  
(a)  $x - \frac{3}{x} = 4$                       (b)  $3x - \frac{5}{x} = x^2$                       (c)  $x + \frac{1}{x} = 3$       (d)  $x^2 - 3 = 4x^2 - 4x$
  3. Which of the following is a solution of the quadratic equation  $2x^2 + x - 6 = 0$ ?  
(a)  $x = 2$                       (b)  $x = -12$                       (c)  $x = \frac{3}{2}$                       (d)  $x = -3$
  4. The value of k for which  $x = -2$  is a root of the quadratic equation  $kx^2 + x - 6 = 0$   
(a) -1                      (b) -2                      (c) 2                      (d)  $-\frac{3}{2}$
  5. The value of p so that the quadratic equation  $x^2 + 5px + 16 = 0$  has no real root, is  
(a)  $p > 8$                       (b)  $p < 5$                       (c)  $-\frac{8}{5} < x < \frac{8}{5}$                       (d)  $-\frac{8}{5} \leq x < 0$
  6. If  $px^2 + 3qx + q = 0$  has two roots  $x = -1$  and  $x = -2$ , the value of  $q - p$  is  
(a) -1                      (b) -2                      (c) 1                      (d) 2
  7. The common root of the quadratic equation  $x^2 - 3x + 2 = 0$  and  $2x^2 - 5x + 2 = 0$  is:  
(a)  $x = 2$                       (b)  $x = -2$                       (c)  $x = \frac{1}{2}$                       (d)  $x = 1$
  8. If  $x^2 - 5x + 1 = 0$ , the value of  $\left(x + \frac{1}{x}\right)$  is:  
(a) -5                      (b) -2                      (c) 5                      (d) 3
  9. If  $a - 3 = \frac{10}{a}$ , the value of a are  
(a) -5, 2                      (b) 5, -2                      (c) 5, 2                      (d) 5, 0
  10. If the roots of the quadratic equation  $kx^2 + (a + b)x + ab = 0$  are  $(-1, -b)$ , the value of k is:  
(a) -1                      (b) -2                      (c) 1                      (d) 2
  11. The quadratic equation with real coefficient whose one root is  $2 + \sqrt{3}$  is:  
(a)  $x^2 - 2x + 1 = 0$       (b)  $x^2 - 4x + 1 = 0$       (c)  $x^2 - 4x + 3 = 0$       (d)  $x^2 - 4x + 4 = 0$
  12. If the difference of roots of the quadratic equation  $x^2 + kx + 12 = 0$  is 1, the positive value of k is:  
(a) -7                      (b) 7                      (c) 4                      (d) 8
- .....



**MCQ WORKSHEET-IV**  
**CLASS X: CHAPTER – 4**  
**QUADRATIC EQUATIONS**

1. Find the values of k for which the quadratic equation  $k^2x^2 - 2(k - 1)x + 4 = 0$  has real and equal roots.  
(a)  $k = 0$  or  $k = \frac{1}{3}$     (b)  $k = 1$  or  $k = \frac{1}{3}$     (c)  $k = -1$  or  $k = \frac{1}{3}$     (d)  $k = -3$  or  $k = \frac{1}{3}$
  2. If  $-4$  is a root of the equation  $x^2 + px - 4 = 0$  and the equation  $x^2 + px + q = 0$  has equal roots, find the value of p and q.  
(a)  $p = 3, q = 9$     (b)  $p = 9, q = 3$     (c)  $p = 3, q = \frac{4}{9}$     (d)  $p = 3, q = \frac{9}{4}$
  3. If the roots of the equation  $(a - b)x^2 + (b - c)x + (c - a) = 0$  are equal, then  $b + c =$   
(a)  $2a$     (b)  $2bc$     (c)  $2c$     (d) none of these
  4. Find the positive value of k for which the equations  $x^2 + kx + 64 = 0$  and  $x^2 - 8x + k = 0$  will have real roots.  
(a) 8    (b) 16    (c)  $-8$     (d)  $-16$
  5. Find the positive value of k for which the equation  $kx^2 - 6x - 2 = 0$  has real roots  
(a)  $k \leq \frac{-9}{2}$     (b)  $k \geq \frac{-9}{2}$     (c)  $k > \frac{-9}{2}$     (d)  $k < \frac{-9}{2}$
  6. Find the positive value of k for which the equation  $3x^2 + 2x + k = 0$  has real roots  
(a)  $k \geq \frac{1}{3}$     (b)  $k \leq \frac{1}{3}$     (c)  $k > \frac{1}{3}$     (d)  $k < \frac{1}{3}$
  7. Find the positive value of k for which the equation  $2x^2 + kx + 2 = 0$  has real roots  
(a)  $k \geq 4$     (b)  $k \leq -4$     (c) both (a) and (c)    (d) none of these.
  8. The sum of a number and its reciprocal is  $\frac{10}{3}$ . Find the number.  
(a) 3    (b)  $\frac{1}{3}$     (c) both (a) and (c)    (d) none of these
  9. Divide 12 into two parts such that the sum of their squares is 74.  
(a) 7 and 5    (b) 8 and 4    (c) 10 and 2    (d) none of these
  10. The sum of the squares of two consecutive natural numbers is 421. Find the numbers.  
(a) 14 and 5    (b) 14 and 15    (c) 10 and 5    (d) none of these
  11. The sum of two numbers is 15 and the sum of their reciprocals is  $\frac{3}{10}$ . Find the numbers.  
(a) 14 and 5    (b) 14 and 15    (c) 10 and 5    (d) none of these
  12. Divide 12 into two parts such that their product is 32.  
(a) 7 and 5    (b) 8 and 4    (c) 10 and 2    (d) none of these
- .....

**PRACTICE QUESTIONS**  
**CLASS X : CHAPTER - 4**  
**QUADRATIC EQUATIONS**  
**FACTORISATION METHOD**

Solve the following quadratic equations:

1.  $x^2 + 11x + 30 = 0$

2.  $x^2 + 18x + 32 = 0$

3.  $x^2 + 7x - 18 = 0$

4.  $x^2 + 5x - 6 = 0$

5.  $y^2 - 4y + 3 = 0$

6.  $x^2 - 21x + 108 = 0$

7.  $x^2 - 11x - 80 = 0$

8.  $x^2 - x - 156 = 0$

9.  $z^2 - 32z - 105 = 0$

10.  $40 + 3x - x^2 = 0$

11.  $6 - x - x^2 = 0$

12.  $7x^2 + 49x + 84 = 0$

13.  $m^2 + 17mn - 84n^2 = 0$

14.  $5x^2 + 16x + 3 = 0$

15.  $6x^2 + 17x + 12 = 0$

16.  $9x^2 + 18x + 8 = 0$

17.  $14x^2 + 9x + 1 = 0$

18.  $2x^2 + 3x - 90 = 0$

19.  $2x^2 + 11x - 21 = 0$

20.  $3x^2 - 14x + 8 = 0$

21.  $18x^2 + 3x - 10 = 0$

22.  $15x^2 + 2x - 8 = 0$

23.  $6x^2 + 11x - 10 = 0$

24.  $30x^2 + 7x - 15 = 0$

25.  $24x^2 - 41x + 12 = 0$

26.  $2x^2 - 7x - 15 = 0$

27.  $6x^2 + 11x - 10 = 0$

28.  $10x^2 - 9x - 7 = 0$

29.  $5x^2 - 16x - 21 = 0$

30.  $2x^2 - x - 21 = 0$

31.  $15x^2 - x - 28 = 0$

32.  $8a^2 - 27ab + 9b^2 = 0$

33.  $5x^2 + 33xy - 14y^2 = 0$

34.  $3x^3 - x^2 - 10x = 0$

35.  $x^2 + 9x + 18 = 0$

36.  $x^2 + 5x - 24 = 0$

37.  $x^2 - 4x - 21 = 0$

38.  $6x^2 + 7x - 3 = 0$

39.  $2x^2 - 7x - 39 = 0$

40.  $9x^2 - 22x + 8 = 0$

41.  $6x^2 + 40 = 31x$

42.  $36x^2 - 12ax + (a^2 - b^2) = 0$

43.  $8x^2 - 22x - 21 = 0$

44.  $2x^2 - x + \frac{1}{8} = 0$

45.  $4\sqrt{3}x^2 + 5x - 2\sqrt{3} = 0$

**PRACTICE QUESTIONS**  
**CLASS X : CHAPTER - 4**  
**QUADRATIC EQUATIONS**  
**FACTORISATION METHOD**

Solve the following by Factorisation method:

1.  $\sqrt{2}x^2 + 7x + 5\sqrt{2} = 0$

2.  $2x - \frac{3}{x} = 1$

3.  $\frac{4}{x} - 3 = \frac{5}{2x+3}, x \neq 0, \frac{-3}{2}$

4.  $\frac{x}{x+1} + \frac{x+1}{x} = \frac{34}{15}, x \neq -1 \text{ and } x \neq 0$

5.  $\frac{x+3}{x+2} = \frac{3x-7}{2x-3}$

6.  $\frac{x-1}{x-2} + \frac{x-3}{x-4} = 3\frac{1}{3} (x \neq 2, 4)$

7.  $\frac{1}{a+b+x} = \frac{1}{a} + \frac{1}{b} + \frac{1}{x}, [x \neq 0, -(a+b)]$

8.  $2\left(\frac{2x-1}{x+3}\right) - 3\left(\frac{x+3}{2x-1}\right) = 5, x \neq -3, \frac{1}{2}$

9.  $5^{(x+1)} + 5^{(2-x)} = 5^3 + 1$

10.  $5x - \frac{35}{x} = 18, x \neq 0$

11.  $2^{2x} - 3 \cdot 2^{(x+2)} + 32 = 0$

12.  $4^{(x+1)} + 4^{(1-x)} = 10$

13.  $3^{(x+2)} + 3^{-x} = 10$

14.  $10x - \frac{1}{x} = 3$

15.  $\frac{2}{x^2} - \frac{5}{x} + 2 = 0$

16.  $\sqrt{3}x^2 + 11x + 6\sqrt{3} = 0$

17.  $4\sqrt{3}x^2 + 5x - 2\sqrt{3} = 0$

18.  $3\sqrt{7}x^2 + 4x - \sqrt{7} = 0$

19.  $\sqrt{7}x^2 - 6x - 13\sqrt{7} = 0$

20.  $4\sqrt{6}x^2 - 13x - 2\sqrt{6} = 0$

21.  $x^2 - (1 + \sqrt{2})x + \sqrt{2} = 0$
22.  $\left(\frac{4x-3}{2x+1}\right) - 10\left(\frac{2x+1}{4x-3}\right) = 3, \left(x \neq \frac{-1}{2}, \frac{3}{4}\right)$
23.  $\left(\frac{x}{x+1}\right)^2 - 5\left(\frac{x}{x+1}\right) + 6 = 0, (x \neq -1)$
24.  $2\left(\frac{2x-1}{x+3}\right) - 3\left(\frac{x+3}{2x-1}\right) = 5, \left(x \neq -3, \frac{1}{2}\right)$
25.  $2\left(\frac{x-1}{x+3}\right) - 7\left(\frac{x+3}{x-1}\right) = 5, (x \neq -3, 1)$
26.  $\frac{a}{x-b} + \frac{b}{x-a} = 2, (x \neq a, b)$
27.  $\frac{a}{ax-1} + \frac{b}{bx-1} = a+b, \left(x \neq \frac{1}{a}, \frac{1}{b}\right)$
28.  $\frac{x+3}{x-2} - \frac{1-x}{x} = \frac{17}{4}, (x \neq 0, 2)$
29.  $\frac{2x}{x-4} + \frac{2x-5}{x-3} = \frac{25}{3}, (x \neq 4, 3)$
30.  $\frac{1}{x-3} - \frac{1}{x+5} = \frac{1}{6}, (x \neq 3, -5)$
31.  $\frac{1}{x-2} + \frac{2}{x-1} = \frac{6}{x}, (x \neq 2, 1)$
32.  $\frac{1}{x+4} - \frac{1}{x-7} = \frac{11}{30}, (x \neq -4, 7)$
33.  $\frac{1}{x-2} + \frac{1}{x-4} = \frac{4}{3}, (x \neq 2, 4)$
34.  $\frac{x-3}{x+3} - \frac{x+3}{x-3} = 6\frac{6}{7}, (x \neq -3, 3)$
35.  $\frac{2x}{x-3} + \frac{1}{2x+3} + \frac{3x+9}{(x-3)(2x+3)} = 0$
36.  $x = \frac{1}{2 - \frac{1}{2 - \frac{1}{2-x}}}, x \neq 2$
37.  $4x^2 - 2(a^2 + b^2)x + a^2b^2 = 0$
38.  $9x^2 - 9(a+b)x + (2a^2 + 5ab + 2b^2) = 0$
39.  $4x^2 - 4a^2x + (a^4 - b^4) = 0$

$$40. x^2 + \left( \frac{a+b}{a} + \frac{a}{a+b} \right) x + 1 = 0$$

$$41. x^2 + x - (a+1)(a+2) = 0$$

$$42. x^2 + 3x - (a^2 + a - 2) = 0$$

$$43. a^2 b^2 x^2 + b^2 x - a^2 x - 1 = 0$$

$$44. x + \frac{1}{x} = 25 \frac{1}{25}$$

$$45. (x-3)(x-4) = \frac{34}{(33)^2}$$

$$46. x^2 + \left( a + \frac{1}{a} \right) x + 1 = 0$$

$$47. (a+b)^2 x^2 - 4abx - (a-b)^2 = 0$$

$$48. 7x + \frac{3}{x} = 35 \frac{3}{5}$$

$$49. \frac{x-a}{x-b} + \frac{x-b}{x-a} = \frac{a}{b} + \frac{b}{a}$$

$$50. (x-5)(x-6) = \frac{25}{(24)^2}$$

.....

**PRACTICE QUESTIONS**  
**CLASS X : CHAPTER - 4**  
**QUADRATIC EQUATIONS**  
**METHOD OF COMPLETING THE SQUARE**

Solve the following quadratic equation (if they exist) by the method of completing the square:

1.  $8x^2 - 22x - 21 = 0$
2.  $2x^2 - x + \frac{1}{8} = 0$
3.  $4\sqrt{3}x^2 + 5x - 2\sqrt{3} = 0$
4.  $\sqrt{2}x^2 + 7x + 5\sqrt{2} = 0$
5.  $9x^2 - 15x + 6 = 0$
6.  $2x^2 - 5x + 3 = 0$
7.  $4x^2 + 3x + 5 = 0$
8.  $5x^2 - 6x - 2 = 0$
9.  $4x^2 + 4bx - (a^2 - b^2) = 0$
10.  $a^2x^2 - 3abx + 2b^2 = 0$
11.  $x^2 - (\sqrt{3} + 1)x + \sqrt{3} = 0$
12.  $x^2 - 4ax + 4a^2 - b^2 = 0$
13.  $x^2 - (\sqrt{2} + 1)x + \sqrt{2} = 0$
14.  $\sqrt{3}x^2 + 10x + 7\sqrt{3} = 0$
15.  $\sqrt{2}x^2 - 3x - 2\sqrt{2} = 0$
16.  $4x^2 + 4\sqrt{3}x + 3 = 0$
17.  $2x^2 + x + 4 = 0$
18.  $2x^2 + x - 4 = 0$
19.  $3x^2 + 11x + 10 = 0$
20.  $2x^2 - 7x + 3 = 0$
21.  $5x^2 - 19x + 17 = 0$
22.  $2x^2 + x - 6 = 0$
23.  $2x^2 - 9x + 7 = 0$
24.  $6x^2 + 7x - 10 = 0$
25.  $x^2 - 4\sqrt{2}x + 6 = 0$

**PRACTICE QUESTIONS**  
**CLASS X : CHAPTER - 4**  
**QUADRATIC EQUATIONS**  
**METHOD OF QUADRATIC FORMULA**

Show that each of the following equations has real roots, and solve each by using the quadratic formula:

1.  $9x^2 + 7x - 2 = 0$

2.  $x^2 + 6x + 6 = 0$

3.  $2x^2 + 5\sqrt{3}x + 6 = 0$

4.  $36x^2 - 12ax + (a^2 - b^2) = 0$

5.  $a^2b^2x^2 - (4b^4 - 3a^4)x - 12a^2b^2 = 0$

6.  $(a+b)^2x^2 - 4abx - (a-b)^2 = 0$

7.  $4x^2 - 2(a^2 + b^2)x + a^2b^2 = 0$

8.  $9x^2 - 9(a+b)x + (2a^2 + 5ab + 2b^2) = 0$

9.  $4x^2 - 4a^2x + (a^4 - b^4) = 0$

10.  $\sqrt{3}x^2 + 11x + 6\sqrt{3} = 0$

11.  $4\sqrt{3}x^2 + 5x - 2\sqrt{3} = 0$

12.  $3\sqrt{7}x^2 + 4x - \sqrt{7} = 0$

13.  $\sqrt{7}x^2 - 6x - 13\sqrt{7} = 0$

14.  $4\sqrt{6}x^2 - 13x - 2\sqrt{6} = 0$

15.  $x^2 - (1 + \sqrt{2})x + \sqrt{2} = 0$

16.  $2x^2 + 5\sqrt{3}x + 6 = 0$

17.  $x^2 - 2x + 1 = 0$

18.  $3x^2 + 2\sqrt{5}x - 5 = 0$

19.  $3a^2x^2 + 8abx + 4b^2 = 0, a \neq 0$

20.  $2x^2 - 2\sqrt{6}x + 3 = 0$

21.  $3x^2 - 2x + 2 = 0$

22.  $\sqrt{3}x^2 + 10x - 8\sqrt{3} = 0$

23.  $x^2 + x + 2 = 0$

24.  $16x^2 = 24x + 1$

25.  $25x^2 + 20x + 7 = 0$

26.  $6x^2 + x - 2 = 0$

27.  $x^2 + 5x + 5 = 0$

28.  $p^2x^2 + (p^2 - q^2)x - q^2 = 0$

29.  $abx^2 + (b^2 - ac)x - bc = 0$

30.  $x^2 - 2ax + (a^2 - b^2) = 0$

31.  $12abx^2 - (9a^2 - 8b^2)x - 6ab = 0$

32.  $24x^2 - 41x + 12 = 0$

33.  $2x^2 - 7x - 15 = 0$

34.  $6x^2 + 11x - 10 = 0$

35.  $10x^2 - 9x - 7 = 0$

36.  $x^2 - x - 156 = 0$

37.  $z^2 - 32z - 105 = 0$

38.  $40 + 3x - x^2 = 0$

39.  $6 - x - x^2 = 0$

40.  $7x^2 + 49x + 84 = 0$

**PRACTICE QUESTIONS**  
**CLASS X : CHAPTER - 4**  
**QUADRATIC EQUATIONS**  
**NATURE OF ROOTS**

1. Find the value of  $k$  for which the quadratic equation  $2x^2 + kx + 3 = 0$  has two real equal roots.
2. Find the value of  $k$  for which the quadratic equation  $kx(x - 3) + 9 = 0$  has two real equal roots.
3. Find the value of  $k$  for which the quadratic equation  $4x^2 - 3kx + 1 = 0$  has two real equal roots..
4. If  $-4$  is a root of the equation  $x^2 + px - 4 = 0$  and the equation  $x^2 + px + q = 0$  has equal roots, find the value of  $p$  and  $q$ .
5. If  $-5$  is a root of the equation  $2x^2 + px - 15 = 0$  and the equation  $p(x^2 + x) + k = 0$  has equal roots, find the value of  $k$ .
6. Find the value of  $k$  for which the quadratic equation  $(k - 12)x^2 + 2(k - 12)x + 2 = 0$  has two real equal roots..
7. Find the value of  $k$  for which the quadratic equation  $k^2x^2 - 2(k - 1)x + 4 = 0$  has two real equal roots..
8. If the roots of the equation  $(a - b)x^2 + (b - c)x + (c - a) = 0$  are equal, prove that  $b + c = 2a$ .
9. Prove that both the roots of the equation  $(x - a)(x - b) + (x - b)(x - c) + (x - c)(x - a) = 0$  are real but they are equal only when  $a = b = c$ .
10. Find the positive value of  $k$  for which the equation  $x^2 + kx + 64 = 0$  and  $x^2 - 8x + k = 0$  will have real roots.
11. Find the value of  $k$  for which the quadratic equation  $kx^2 - 6x - 2 = 0$  has two real roots.
12. Find the value of  $k$  for which the quadratic equation  $3x^2 + 2x + k = 0$  has two real roots.
13. Find the value of  $k$  for which the quadratic equation  $2x^2 + kx + 2 = 0$  has two real roots.
14. Show that the equation  $3x^2 + 7x + 8 = 0$  is not true for any real value of  $x$ .
15. Show that the equation  $2(a^2 + b^2)x^2 + 2(a + b)x + 1 = 0$  has no real roots, when  $a \neq b$ .
16. Find the value of  $k$  for which the quadratic equation  $kx^2 + 2x + 1 = 0$  has two real and distinct roots.
17. Find the value of  $p$  for which the quadratic equation  $2x^2 + px + 8 = 0$  has two real and distinct roots.
18. If the equation  $(1 + m^2)x^2 + 2mcx + (c^2 - a^2) = 0$  has equal roots, prove that  $c^2 = a^2(1 + m^2)$ .



19. If the roots of the equation  $(c^2 - ab)x^2 - 2(a^2 - bc)x + (b^2 - ac) = 0$  are real and equal, show that either  $a = 0$  or  $(a^3 + b^3 + c^3) = 3abc$ .
20. Find the value of  $k$  for which the quadratic equation  $9x^2 + 8kx + 16 = 0$  has two real equal roots.
21. Find the value of  $k$  for which the quadratic equation  $(k + 4)x^2 + (k+1)x + 1 = 0$  has two real equal roots.
22. Prove that the equation  $x^2(a^2 + b^2) + 2x(ac + bd) + (c^2 + d^2) = 0$  has no real root, if  $ad \neq bc$ .
23. If the roots of the equation  $x^2 + 2cx + ab = 0$  are real unequal, prove that the equation  $x^2 - 2(a + b) + a^2 + b^2 + 2c^2 = 0$  has no real roots.
24. Find the positive values of  $k$  for which the equation  $x^2 + kx + 64 = 0$  and  $x^2 - 8x + k = 0$  will both have real roots.
25. Find the value of  $k$  for which the quadratic equation  $(k + 4)x^2 + (k + 1)x + 1 = 0$  has equal roots.
26. Find the value of  $k$  for which the quadratic equation  $x^2 - 2(k + 1)x + k^2 = 0$  has real and equal roots.
27. Find the value of  $k$  for which the quadratic equation  $k^2x^2 - 2(2k - 1)x + 4 = 0$  has real and equal roots.
28. Find the value of  $k$  for which the quadratic equation  $(k + 1)x^2 - 2(k - 1)x + 1 = 0$  has real and equal roots.
29. Find the value of  $k$  for which the quadratic equation  $(4 - k)x^2 + (2k + 4)x + (8k + 1) = 0$  has real and equal roots.
30. Find the value of  $k$  for which the quadratic equation  $(2k + 1)x^2 + 2(k + 3)x + (k + 5) = 0$  has real and equal roots.
- .....

**PRACTICE QUESTIONS**  
**CLASS X : CHAPTER - 4**  
**QUADRATIC EQUATIONS**  
**WORD PROBLEMS CATEGORY WISE**

**I. NUMBER BASED QUESTIONS**

**DIRECT QUESTIONS**

1. The difference of two numbers is 5 and the difference of their reciprocals is  $\frac{1}{10}$ . Find the numbers.
2. Find two consecutive odd positive integers, sum of whose squares is 290.
3. The difference of the squares of two numbers is 45. The squares of the smaller number are 4 times the larger number. Find the numbers.
4. The sum of the squares of the two positive integers is 208. If the square of the larger number is 18 times the smaller number, find the numbers.
5. The denominator of a fraction is 3 more than its numerator. The sum of the fraction and its reciprocal is  $2\frac{9}{10}$ . Find the fraction.
6. The denominator of a fraction is one more than twice the numerator. The sum of the fraction and its reciprocal is  $2\frac{16}{21}$ . Find the fraction.
7. Two numbers differ by 3 and their product is 504. Find the numbers.
8. Find three consecutive positive integers such that the sum of the square of the first and the product of the other two is 154.
9. The sum of two numbers is 16 and the sum of their reciprocals is  $\frac{1}{3}$ . Find the numbers.
10. The sum of two numbers is 18 and the sum of their reciprocals is  $\frac{1}{4}$ . Find the numbers.
11. The sum of two numbers is 25 and the sum of their reciprocals is  $\frac{3}{10}$ . Find the numbers.
12. The sum of two numbers is 15 and the sum of their reciprocals is  $\frac{3}{10}$ . Find the numbers.
13. The sum of a number and its reciprocal is  $3\frac{41}{80}$ . Find the numbers.
14. The sum of the squares of three consecutive positive integers is 50. Find the integers.
15. Find two natural numbers, the sum of whose squares is 25 times their sum and also equal to 50 times their difference.

**TWO-DIGIT PROBLEMS**

1. A two digit number is such that the product of its digits is 12. When 36 is added to the number, the digits are reversed. Find the number.
2. A two digit number is such that the product of its digits is 8. When 54 is subtracted from the number, the digits are reversed. Find the number.
3. A two digit number is four times the sum and twice the product of its digits. Find the number
4. A two digit number is such that the product of its digits is 14. When 45 is added to the number, the digits interchange their places. Find the number.

5. A two digit number is such that the product of its digits is 18. When 63 is subtracted from the number, the digits interchange their places. Find the number.
6. A two digit number is four times the sum and three times the product of its digits. Find the number
7. A two digit number is such that the product of its digits is 8. When 18 is subtracted from the number, the digits are reversed. Find the number.
8. A two digit number is 4 times the sum of its digits and twice the product of its digits. Find the number.
9. A two digit number is 5 times the sum of its digits and is also equal to 5 more than twice the product of its digits. Find the number.
10. A two digit number is such that the product of its digits is 35. When 18 is added to the number, the digits interchange their places. Find the number.

## **II. AGE RELATED QUESTIONS**

1. The sum of ages of a father and his son is 45 years. Five years ago, the product of their ages in years was 124. Find their present ages.
2. Seven years ago Varun's age was five times the square of Swati's age. Three years hence Swati's age will be two fifth of Varun's age. Find their present ages.
3. The product of Rohit's age five years ago with his age 9 years later is 15 in years. Find his present age.
4. The product of Archana's age five years ago with her age 8 years later is 30 in years. Find her present age.
5. The sum of the ages of a man and his son is 45 years. Five years ago, the product of their ages in years was four times the man's age at that time. Find their present ages.
6. The sum of the ages of a boy and his brother is 25 years and the product of their ages in years is 126. Find their ages.
7. The sum of the ages of a boy and his brother is 12 years and the sum of the square of their ages is 74 in years. Find their ages.
8. A boy is one year older than his friend. If the sum of the square of their ages is 421, find their ages.
9. The difference of the ages of a boy and his brother is 3 and the product of their ages in years is 504. Find their ages.
10. The sum of the ages of a boy and his brother is 57 years and the product of their ages in years is 782. Find their ages.

## **III. SPEED, DISTANCE AND TIME RELATED QUESTIONS**

1. A motor boat whose speed is 18 km/hr in still water takes 1 hour more to go 24 upstream than to return to the same point. Find the speed of the stream.
2. A motorboat whose speed is 9km/hr in still water, goes 15 km downstream and comes back in a total time of 3 hours 45 minutes. Find the speed of the stream.
3. A passenger train takes 2 hours less for a journey of 300 km if its speed is increased by 5 km/hr from its usual speed. Find its usual speed.
4. In a flight for 3000 km, an aircraft was slowed down due to bad weather. Its average speed for the trip was reduced by 100 km/hr and consequently time of flight increased by one hour. Find the original duration of flight.
5. A plane left 30 minutes later than the schedule time and in order to reach its destination 1500 km away in time it has to increase its speed by 250 km/hr from its usual speed. Find its usual speed.
6. An express train takes 1 hour less than a passenger train to travel 132 km between Mysore and Bangalore (without taking into consideration the time they stop at intermediate stations). If the

average speed of the express train is 11km/h more than that of the passenger train, find the average speed of the two trains.

7. A train travels 360 km at a uniform speed. If the speed had been 5 km/h more, it would have taken 1 hour less for the same journey. Find the speed of the train.
8. In a flight for 6000 km, an aircraft was slowed down due to bad weather. Its average speed for the trip was reduced by 400 km/hr and consequently time of flight increased by 30 minutes. Find the original duration of flight.
9. The time taken by a man to cover 300 km on a scooter was  $1\frac{1}{2}$  hours more than the time taken by him during the return journey. If the speed in returning be 10 km/hr more than the speed in going, find its speed in each direction.
10. A motorboat whose speed is 15 km/hr in still water, goes 30 km downstream and comes back in a total time of 4 hours 30 minutes. Find the speed of the stream.
11. The speed of a boat in still water is 8 km/hr. It can go 15 km upstream and 22 km downstream in 5 hours. Find the speed of the stream.
12. A motor boat goes 10 km upstream and returns back to the starting point in 55 minutes. If the speed of the motor boat in still water is 22 km/hr, find the speed of the current.
13. A sailor can row a boat 8 km downstream and return back to the starting point in 1 hour 40 minutes. If the speed of the stream is 2 km/hr, find the speed of the boat in still water.
14. A train covers a distance of 90 km at a uniform speed. Had the speed been 15 km/hr more, it would have taken 30 minutes less for the journey. Find the original speed of the train.
15. The distance between Mumbai and Pune is 192 km. Travelling by the Deccan Queen, it takes 48 minutes less than another train. Calculate the speed of the Deccan Queen if the speeds of the two trains differ by 20 km/hr.
16. An aeroplane left 30 minutes later than its scheduled time and in order to reach its destination 1500 km away in time, it had to increase its speed by 250 km/hr from its usual speed. Determine its usual speed.

#### **IV. GEOMETRICAL FIGURES RELATED QUESTIONS**

1. The sum of the areas of two squares is 640 m<sup>2</sup>. If the difference in their perimeters be 64 m, find the sides of the two squares.
2. The hypotenuse of a right triangle is  $3\sqrt{10}$  cm. If the smaller side is tripled and the longer sides doubled, new hypotenuse will be  $9\sqrt{5}$  cm. How long are the sides of the triangle?
3. A pole has to be erected at a point on the boundary of a circular park of diameter 13 metres in such a way that the differences of its distances from two diametrically opposite fixed gates A and B on the boundary is 7 metres. Is it possible to do so? If yes, at what distances from the two gates should the pole be erected?
4. The sum of the areas of two squares is 468 m<sup>2</sup>. If the difference of their perimeters is 24 m, find the sides of the two squares.
5. The hypotenuse of a right triangle is  $3\sqrt{5}$  cm. If the smaller side is tripled and the longer sides doubled, new hypotenuse will be 15 cm. How long are the sides of the triangle?
6. The hypotenuse of right-angled triangle is 6 m more than twice the shortest side. If the third side is 2 m less than the hypotenuse, find the sides of the triangle.
7. The hypotenuse of a right triangle is 25 cm. The difference between the lengths of the other two sides of the triangle is 5 cm. Find the lengths of these sides.
8. The diagonal of a rectangular field is 60 m more than the shortest side. If the longer side is 30 m more than the shorter side, find the sides of the field.
9. The perimeter of a right triangle is 60 cm. Its hypotenuse is 25 cm. Find the area of the triangle.
10. The side of a square exceeds the side of the another square by 4 cm and the sum of the areas of the two squares is 400 cm<sup>2</sup>. Find the dimensions of the squares.

11. The length of the rectangle exceeds its breadth by 8 cm and the area of the rectangle is  $240 \text{ cm}^2$ . Find the dimensions of the rectangle.
12. A chess board contains 64 squares and the area of each square is  $6.25 \text{ cm}^2$ . A border round the board is 2 cm wide. Find the length of the side of the chess board.
13. A rectangular field is 25 m long and 16 m broad. There is a path of equal width all around inside it. If the area of the path is  $148 \text{ m}^2$ , find the width of the path.
14. The length of a rectangle is thrice as long as the side of a square. The side of the square is 4 cm more than the breadth of the rectangle. Their areas being equal, find their dimensions.
15. A farmer prepares a rectangular vegetable garden of area  $180 \text{ m}^2$ . With 39 m of barbed wire, he can fence the three sides of the garden, leaving one of the longer sides unfenced. Find the dimensions of the garden.
16. A rectangular field is 16 m long and 10 m broad. There is a path of equal width all around inside it. If the area of the path is  $120 \text{ m}^2$ , find the width of the path.
17. The area of right triangle is  $600 \text{ cm}^2$ . If the base of the triangle exceeds the altitude by 10 cm, find the dimensions of the triangle.
18. The area of right triangle is  $96 \text{ m}^2$ . If the base of the triangle three times the altitude, find the dimensions of the triangle.
19. The length of the hypotenuse of a right triangle exceeds the length of the base by 2 cm and exceeds twice the length of the altitude by 1 cm. Find the length of each side of the triangle.
20. The hypotenuse of a right triangle is 1 m less than twice the shortest side. If the third side is 1 m more than the shortest side, find the sides of the triangle.

## **V. TIME AND WORK RELATED QUESTIONS**

1. Two water taps together can fill a tank in  $9\frac{3}{8}$  hours. The tap of larger diameter takes 10 hours less than the smaller one to fill the tank separately. Find the time in which each tap can separately fill the tank.
2. A takes 6 days less than the time taken by B to finish a piece of work. If both A and B together can finish it in 4 days, find the time taken by B to finish the work.
3. Two pipes running together can fill a cistern in  $3\frac{1}{13}$  hours. If one pipe takes 3 minutes more than the other to fill the cistern. Find the time in which each pipe can separately fill the cistern.
4. A takes 10 days less than the time taken by B to finish a piece of work. If both A and B together can finish it in 12 days, find the time taken by B to finish the work.
5. If two pipes function simultaneously, a reservoir will be filled in 12 hours. One pipe fills the reservoir 10 hours faster than the other. How many hours will the second pipe take to fill the reservoir?

## **VI. REASONING BASED QUESTIONS**

1. In a class test, the sum of Ranjitha's marks in mathematics and English is 40. Had she got 3 marks more in mathematics and 4 marks less in English, the product of the marks would have been 360. Find her marks in two subjects separately.
2. Out of a number of saras birds, one-fourth of the number are moving about in lots,  $\frac{1}{9}$ th coupled with  $\frac{1}{4}$ th as well as 7 times the square root of the number move on a hill, 56 birds remain in vakula trees. What is the total number of trees?

3. A teacher attempting to arrange the students for mass drill in the form of a solid square found that 24 students were left. When he increased the size of the square by 1 student, he found that he was short of 25 students. Find the number of students.
4. A rectangular park is to be designed whose breadth is 3 m less than its length. Its area is to be 4 square metres more than the area of a park that has already been made in the shape of an isosceles triangle with its base as the breadth of the rectangular park and of altitude 12 m (see Fig. 4.3). Find its length and breadth.
5. John and Jivanti together have 45 marbles. Both of them lost 5 marbles each, and the product of the number of marble they now have is 124. We would like to find out how many marbles they had to start with.
6. In a class test, the sum of Shefali's marks in Mathematics and English is 30. Had she got 2 marks more in Mathematics and 3 marks less in English, the product of their marks would have been 210. Find her marks in the two subjects.
7. 300 apples are distributed equally among a certain number of students. Had there been 10 more students, each would have received one apple less. Find the number of students.
8. A man buys a number of pens for Rs. 80. If he has bought 4 more pens for the same amount, each pen would have cost him Re. 1 less. How many pens did he buy?
9. One-fourth of a herd of camels was seen in the forest. Twice the square root of the herd had gone to mountains and the remaining 15 camels were seen on the bank of a river. Find the total number of camels.
10. Out of a group of swans,  $\frac{7}{2}$  times the square root of the number are playing on the shore of a tank. The two remaining ones are playing with amorous fight in the water. What is the total number of swans?
11. In a class test, the sum of the marks obtained by P in mathematics and science is 28. Had he got 3 more marks in mathematics and 4 marks less in science, the product of marks obtained in the two subjects would have been 180. Find the marks obtained by him in the two subjects separately.
12. Rs 250 was divided equally among a certain number of children. If there were 25 more children, each would have received 50 paise less. Find the number of children.
13. A peacock is sitting on the top of a pillar, which is 9m high. From a point 27 m away from the bottom of the pillar, a snake is coming to its hole at the base of the pillar. Seeing the snake the peacock pounces on it. If their speeds are equal at what distance from the whole is the snake caught?
14. A shopkeeper buys a number of books for Rs. 80. If he had bought 4 more books for the same amount, each book would have cost Rs. 1 less. How many books did he buy?
15. If the list price of a toy is reduced by Rs. 2, a person can buy 2 toys more for Rs. 360. Find the original price of the toy.



**CLASS X : CHAPTER - 5**  
**ARITHMETIC PROGRESSION (AP)**

**IMPORTANT FORMULAS & CONCEPTS**

**SEQUENCE**

An arrangement of numbers in a definite order according to some rule is called a sequence. In other words, a pattern of numbers in which succeeding terms are obtained from the preceding term by adding/subtracting a fixed number or by multiplying with/dividing by a fixed number, is called sequence or list of numbers.

e.g. 1,2,3,4,5

A sequence is said to be finite or infinite accordingly it has finite or infinite number of terms. The various numbers occurring in a sequence are called its terms.

**ARITHMETIC PROGRESSION ( AP ).**

An **arithmetic progression** is a list of numbers in which each term is obtained by adding a fixed number to the preceding term except the first term.

This fixed number is called the common difference of the AP. It can be positive, negative or zero.

Let us denote the first term of an AP by  $a_1$ , second term by  $a_2$ , . . . ,  $n$ th term by  $a_n$  and the common difference by  $d$ . Then the AP becomes  $a_1, a_2, a_3, . . . , a_n$ .

So,  $a_2 - a_1 = a_3 - a_2 = . . . = a_n - a_{n-1} = d$ .

The general form of an arithmetic progression is given by

$$a, a + d, a + 2d, a + 3d, . . .$$

where  $a$  is the first term and  $d$  the common difference.

**$n$ th Term of an AP**

Let  $a_1, a_2, a_3, . . .$  be an AP whose first term  $a_1$  is  $a$  and the common difference is  $d$ .

Then,

the **second term**  $a_2 = a + d = a + (2 - 1) d$

the **third term**  $a_3 = a_2 + d = (a + d) + d = a + 2d = a + (3 - 1) d$

the **fourth term**  $a_4 = a_3 + d = (a + 2d) + d = a + 3d = a + (4 - 1) d$

.....  
.....

Looking at the pattern, we can say that the  **$n$ th term**  $a_n = a + (n - 1) d$ .

So, **the  $n$ th term  $a_n$  of the AP with first term  $a$  and common difference  $d$  is given by**

$$a_n = a + (n - 1) d.$$

$a_n$  is also called the **general term of the AP**. If there are  $m$  terms in the AP, then  $a_m$  represents the **last term which is sometimes also denoted by  $l$** .

**$n$ th Term from the end of an AP**

Let the last term of an AP be ' $l$ ' and the common difference of an AP is ' $d$ ' then the  $n$ th term from the end of an AP is given by

$$l_n = l - (n - 1) d.$$

### Sum of First $n$ Terms of an AP

The sum of the first  $n$  terms of an AP is given by

$$S_n = \frac{n}{2}[2a + (n-1)d]$$

where  $a$  = first term,  $d$  = common difference and  $n$  = number of terms.

Also, it can be written as

$$S_n = \frac{n}{2}[a + a_n]$$

where  $a_n$  =  $n$ th terms

or

$$S_n = \frac{n}{2}[a + l]$$

where  $l$  = last term

This form of the result is useful when the first and the last terms of an AP are given and the common difference is not given..

$$\text{Sum of first } n \text{ positive integers is given by } S_n = \frac{n(n+1)}{2}$$

#### **Problems based on finding $a_n$ if $S_n$ is given.**

Find the  $n$ th term of the AP, follow the steps:

- Consider the given sum of first  $n$  terms as  $S_n$ .
- Find the value of  $S_1$  and  $S_2$  by substituting the value of  $n$  as 1 and 2.
- The value of  $S_1$  is  $a_1$  i.e.  $a$  = first term and  $S_2 - S_1 = a_2$
- Find the value of  $a_2 - a_1 = d$ , common difference.
- By using the value of  $a$  and  $d$ , Write AP.

#### **Problems based on finding $S_n$ if $a_n$ is given.**

Find the sum of  $n$  term of an AP, follow the steps:

- Consider the  $n$ th term of an AP as  $a_n$ .
- Find the value of  $a_1$  and  $a_2$  by substituting the value of  $n$  as 1 and 2.
- The value of  $a_1$  is  $a$  = first term.
- Find the value of  $a_2 - a_1 = d$ , common difference.
- By using the value of  $a$  and  $d$ , Write AP.
- By using  $S_n$  formula, simplify the expression after substituting the value of  $a$  and  $d$ .

#### **Arithmetic Mean**

If  $a$ ,  $b$  and  $c$  are in AP, then ' $b$ ' is known as arithmetic mean between ' $a$ ' and ' $c$ '

$$b = \frac{a+c}{2} \text{ i.e. AM between 'a' and 'c' is } \frac{a+c}{2}.$$



**MCQ WORKSHEET-I**  
**CLASS X: CHAPTER – 5**  
**ARITHMETIC PROGRESSION**

1. If  $p - 1$ ,  $p + 3$ ,  $3p - 1$  are in AP, then  $p$  is equal to  
(a) 4 (b) -4 (c) 2 (d) -2
2. The sum of all terms of the arithmetic progression having ten terms except for the first term is 99 and except for the sixth term 89. Find the third term of the progression if the sum of the first term and the fifth term is equal to 10  
(a) 15 (b) 5 (c) 8 (d) 10
3. If in any decreasing arithmetic progression, sum of all its terms, except the first term is equal to -36, the sum of all its terms, except for the last term is zero and the difference of the tenth and the sixth term is equal to -16, then first term of the series is  
(a) 15 (b) 14 (c) 16 (d) 17
4. If the third term of an AP is 12 and the seventh term is 24, then the 10th term is  
(a) 33 (b) 34 (c) 35 (d) 36
5. The first term of an arithmetic progression is unity and the common difference is 4. Which of the following will be a term of this AP ?  
(a) 4551 (b) 10091 (c) 7881 (d) 13531
6. A number 15 is divided into three parts which are in AP and sum of their squares is 83. The smallest part is  
(a) 2 (b) 5 (c) 3 (d) 6
7. How many terms of an AP must be taken for their sum to be equal to 120 if its third term is 9 and the difference between the seventh and second term is 20 ?  
(a) 7 (b) 8 (c) 9 (d) 6
8. 9th term of an AP is 499 and 499th term is 9. The term which is equal to zero is  
(a) 507th (b) 508th (c) 509th (d) 510th
9. The sum of all two digit numbers which when divided by 4 yield unity as remainder is  
(a) 1012 (b) 1201 (c) 1212 (d) 1210
10. An AP consist of 31 terms if its 16th term is  $m$ , then sum of all the terms of this AP is  
(a)  $16m$  (b)  $47m$  (c)  $31m$  (d)  $52m$
11. If a clock strikes once at one O'clock, twice at two O'clock, thrice at 3 O'clock and so on and again once at one O'clock and so on, then how many times will the bell be struck in the course of 2 days ?  
(a) 156 (b) 312 (c) 78 (d) 288
12. In a certain AP, 5 times the 5th term is equal to 8 times the 8th term, then its 13th term is equal to  
(a) 5 (b) 1 (c) 0 (d) 13

**MCQ WORKSHEET-II**  
**CLASS X: CHAPTER – 5**  
**ARITHMETIC PROGRESSION**

1. The sum of 5 numbers in AP is 30 and sum of their squares is 220. Which of the following is the third term ?  
(a) 5      (b) 6      (c) 7      (d) 8
2. If a, b, c, d, e and f are in AP, then  $e - c$  is equal to  
(a)  $2(c - a)$       (b)  $2(f - d)$       (c)  $2(d - c)$       (d)  $d - c$
3. The sum of n terms of the series 2, 5, 8, 11,..... is 60100, then n is  
(a) 100      (b) 150      (c) 200      (d) 250
4. The value of the expression  $1 - 6 + 2 - 7 + 3 - 8 + \dots$  to 100 terms  
(a) -225      (b) -250      (c) -300      (d) -350
5. Four numbers are inserted between the numbers 4 and 39 such that an AP results. Find the biggest of these four numbers  
(a) 30      (b) 31      (c) 32      (d) 33
6. The sum of the first ten terms of an AP is four times the sum of the first five terms, then the ratio of the first term to the common difference is  
(a)  $1/2$       (b) 2      (c)  $1/4$       (d) 4
7. Two persons Anil and Happy joined D. W. Associates. Anil and Happy started with an initial salary of Rs. 50000 and Rs. 64000 respectively with annual increment of Rs.2500 and Rs. 2000 each respectively. In which year will Anil start earning more salary than Happy ?  
(a) 28th      (b) 29th      (c) 30th      (d) 27th
8. A man receives Rs. 60 for the first week and Rs. 3 more each week than the preceding week. How much does he earn by the 20th week ?  
(a) Rs. 1760      (b) Rs. 1770      (c) Rs. 1780      (d) Rs. 1790
9. Find 10th term whose 5th term is 24 and difference between 7th term and 10th term is 15  
(a) 34      (b) 39      (c) 44      (d) 49
10. Find the sum of first n terms of odd natural number.  
(a)  $n^2$       (b)  $n^2 - 1$       (c)  $n^2 + 1$       (d)  $2n - 1$
11. Common difference of an A.P. is -2 and first term is 80. Find the sum if last term is 10.  
(a) 1600      (b) 1620      (c) 1650      (d) 1700
12. Find the sum of first 30 terms of an A. P. whose  $n^{\text{th}}$  term is  $2 + 1/2n$   
(a) 292.5      (b) 290.5      (c) 192.5      (d) none of these
13. Find 15<sup>th</sup> term of -10, -5, 0, 5, -----  
(a) 55      (b) 60      (c) 65      (d) none of these
14. If the numbers a, b, c, d, e form an AP, then the value of  $a - 4b + 6c - 4d + e$  is  
(a) 1      (b) 2      (c) 0      (d) none of these

**MCQ WORKSHEET-III**  
**CLASS X: CHAPTER – 5**  
**ARITHMETIC PROGRESSION**

1. 7th term of an AP is 40. The sum of its first 13th terms is  
(a) 500    (b) 510    (c) 520    (d) 530
  
2. The sum of the first four terms of an AP is 28 and sum of the first eight terms of the same AP is 88. Sum of first 16 terms of the AP is  
(a) 346    (b) 340    (c) 304    (d) 268
  
3. Which term of the AP 4, 9, 14, 19, ..... is 109?  
(a) 14th    (b) 18th    (c) 22nd    (d) 16th
  
4. How many terms are there in the arithmetic series  $1 + 3 + 5 + \dots + 73 + 75$ ?  
(a) 28    (b) 30    (c) 36    (d) 38
  
5.  $51 + 52 + 53 + 54 + \dots + 100 = ?$   
(a) 3775    (b) 4025    (c) 4275    (d) 5050
  
6. How many natural numbers between 1 and 1000 are divisible by 5?  
(a) 197    (b) 198    (c) 199    (d) 200
  
7. If a,  $a - 2$  and  $3a$  are in AP, then the value of a is  
(a)  $-3$     (b)  $-2$     (c) 3    (d) 2
  
8. How many terms are there in the AP 7, 10, 13, ....., 151?  
(a) 50    (b) 55    (c) 45    (d) 49
  
9. The 4th term of an AP is 14 and its 12th term is 70. What is its first term?  
(a)  $-10$     (b)  $-7$     (c) 7    (d) 10
  
10. The first term of an AP is 6 and the common difference is 5. What will be its 11th term?  
(a) 56    (b) 41    (c) 46    (d) none of these
  
11. Which term of the AP 72, 63, 54, ..... is 0?  
(a) 8th    (b) 9th    (c) 11th    (d) 12th
  
12. The 8th term of an AP is 17 and its 14th term is  $-29$ . The common difference of the AP is  
(a)  $-2$     (b) 3    (c) 2    (d) 5
  
13. Which term of the AP 2,  $-1$ ,  $-4$ ,  $-7$ , ..... is  $-40$ ?  
(a) 8th    (b) 15th    (c) 11th    (d) 23rd
  
14. Which term of the AP 20, 17, 14, ..... is the first negative term?  
(a) 8th    (b) 6th    (c) 9th    (d) 7th
  
15. The first, second and last terms of an AP are respectively 4, 7 and 31. How many terms are there in the given AP?  
(a) 10    (b) 12    (c) 8    (d) 13

**MCQ WORKSHEET-IV**  
**CLASS X: CHAPTER – 5**  
**ARITHMETIC PROGRESSION**

1. The common difference of the A. P. whose general term  $a_n = 2n + 1$  is  
(a) 1      (b) 2      (c) - 2      (d) - 1
2. The number of terms in the A.P. 2, 5, 8, ..... , 59 is  
(a) 12      (b) 19      (c) 20      (d) 25
3. The first positive term of the A.P. -11, -8, -5,.... Is  
(a) 1      (b) 3      (c) - 2      (d) - 4
4. The 4<sup>th</sup> term from the end of the A.P. 2, 5, 8, .....,35 is  
(a) 29      (b) 26      (c) 23      (d) 20
5. The 11<sup>th</sup> and 13<sup>th</sup> terms of an A.P. are 35 and 41 respectively its common difference is  
(a) 38      (b) 32      (c) 6      (d) 3
6. The next term of the A.P.  $\sqrt{8}, \sqrt{18}, \sqrt{32}, \dots$  is  
(a)  $5\sqrt{2}$       (b)  $5\sqrt{3}$       (c)  $3\sqrt{3}$       (d)  $4\sqrt{3}$
7. If for an A.P.  $a_5 = a_{10} = 5a$ , then  $a_{15}$  is  
(a) 71      (b) 72      (c) 76      (d) 81
8. Which of the following is not an A.P.?  
(a) 1, 4, 7, ....      (b) 3, 7, 12, 18, .....  
(c) 11, 14, 17, 20, .....      (d) -5, -2, 1, 4,...
9. The sum of first 20 odd natural numbers is  
(a) 281      (b) 285      (c) 400      (d) 421
10. The sum of first 20 natural numbers is  
(a) 110      (b) 170      (c) 190      (d) 210
11. The sum of first 10 multiples of 7 is  
(a) 315      (b) 371      (c) 385      (d) 406
12. If the sum of the A.P. 3, 7, 11, .... Is 210, the number of terms is  
(a) 10      (b) 12      (c) 15      (d) 22
13. Write the next term of the AP  $\sqrt{8}, \sqrt{18}, \sqrt{32}, \dots$   
(a)  $\sqrt{50}$       (b)  $\sqrt{64}$       (c)  $\sqrt{36}$       (d)  $\sqrt{72}$
14. Which term of the AP 21, 18, 15, ..... is zero?  
(a) 8th      (b) 6th      (c) 9th      (d) 7th
15. The sum of first 100 multiples of 5 is  
(a) 50500      (b) 25250      (c) 500      (d) none of these

16. The sum of first 100 multiples of 9 is  
(a) 90900 (b) 25250 (c) 45450 (d) none of these
17. The sum of first 100 multiples of 6 is  
(a) 60600 (b) 30300 (c) 15150 (d) none of these
18. The sum of first 100 multiples of 4 is  
(a) 40400 (b) 20200 (c) 10100 (d) none of these
19. The sum of first 100 multiples of 3 is  
(a) 30300 (b) 15150 (c) 300 (d) none of these
20. The sum of first 100 multiples of 8 is  
(a) 20200 (b) 80800 (c) 40400 (d) none of these
- .....

**PRACTICE QUESTIONS**  
**CLASS X : CHAPTER – 5**  
**ARITHMETIC PROGRESSIONS**  
**“nth term of A.P.”**

- Q1.** Determine the AP whose 3<sup>rd</sup> term is 5 and the 7<sup>th</sup> term is 9.
- Q2.** The 8<sup>th</sup> term of an AP is 37 and its 12<sup>th</sup> term is 57. Find the AP.
- Q3.** The 7<sup>th</sup> term of an AP is – 4 and its 13<sup>th</sup> term is – 16. Find the AP.
- Q4.** If the 10<sup>th</sup> term of an AP is 52 and the 17<sup>th</sup> term is 20 more than the 13<sup>th</sup> term, find the AP.
- Q5.** If the 8<sup>th</sup> term of an AP is 31 and its 15<sup>th</sup> term is 16 more than the 11<sup>th</sup> term, find the AP.
- Q6.** Check whether 51 is a term of the AP 5, 8, 11, 14, .....?
- Q7.** The 6<sup>th</sup> term of an AP is – 10 and its 10<sup>th</sup> term is – 26. Determine the 15<sup>th</sup> term of the AP.
- Q8.** The sum of 4<sup>th</sup> term and 8<sup>th</sup> term of an AP is 24 and the sum of 6<sup>th</sup> and 10<sup>th</sup> terms is 44. Find the AP.
- Q9.** The sum of 5<sup>th</sup> term and 9<sup>th</sup> term of an AP is 72 and the sum of 7<sup>th</sup> and 12<sup>th</sup> terms is 97. Find the AP.
- Q10.** Find the 105<sup>th</sup> term of the A.P.  $4, 4\frac{1}{2}, 5, 5\frac{1}{2}, 6, \dots$
- Q11.** Find 25<sup>th</sup> term of the AP  $5, 4\frac{1}{2}, 4, 3\frac{1}{2}, 3, \dots$
- Q12.** Find the 37<sup>th</sup> term of the AP  $6, 7\frac{3}{4}, 9\frac{1}{2}, 11\frac{3}{4}, \dots$
- Q13.** Find 9<sup>th</sup> term of the AP  $\frac{3}{4}, \frac{5}{4}, \frac{7}{4}, \frac{9}{4}, \dots$
- Q14.** An AP consists of 50 terms of which 3<sup>rd</sup> term is 12 and the last term is 106. Find the 29<sup>th</sup> term.
- Q15.** Determine the AP whose third term is 16 and the 7<sup>th</sup> term exceeds the 5<sup>th</sup> term by 12.
- Q16.** The 17<sup>th</sup> term of an AP exceeds its 10<sup>th</sup> term by 7. Find the common difference.
- Q17.** If the nth term of an AP is  $(5n - 2)$ , find its first term and common difference. Also find its 19<sup>th</sup> term.
- Q18.** If the nth term of an AP is  $(4n - 10)$ , find its first term and common difference. Also find its 16<sup>th</sup> term.
- Q19.** If  $2x, x + 10, 3x + 2$  are in A.P., find the value of x.

- Q20.** If  $x + 1$ ,  $3x$  and  $4x + 2$  are in AP, find the value of  $x$ .
- Q21.** Find the value of  $x$  for which  $(8x + 4)$ ,  $(6x - 2)$  and  $(2x + 7)$  are in AP.
- Q22.** Find the value of  $x$  for which  $(5x + 2)$ ,  $(4x - 1)$  and  $(x + 2)$  are in AP.
- Q23.** Find the value of  $m$  so that  $m + 2$ ,  $4m - 6$  and  $3m - 2$  are three consecutive terms of an AP.
- Q24.** Find the 20th term from the last term of the AP : 3, 8, 13, . . . , 253.
- Q25.** Find the 11th term from the last term (towards the first term) of the AP : 10, 7, 4, . . . , - 62.
- Q26.** Find the 10th term from the last term of the AP : 4, 9, 14, . . . , 254.
- Q27.** Find the 6<sup>th</sup> term from the end of the AP 17, 14, 11, . . . . . (-40).
- Q28.** Find the 8<sup>th</sup> term from the end of the AP 7, 10, 13, . . . . . 184.
- Q29.** Find the 10th term from the last term of the AP : 8, 10, 12, . . . , 126.
- Q30.** Find the 31st term of an AP whose 11th term is 38 and the 16th term is 73.
- Q31.** If the 3rd and the 9th terms of an AP are 4 and -8 respectively, which term of this AP is zero?
- Q32.** Two APs have the same common difference. The difference between their 100th terms is 100, what is the difference between their 1000th terms?
- Q33.** For what value of  $n$ , are the  $n$ th terms of two APs: 63, 65, 67, . . . and 3, 10, 17, . . . equal?
- Q34.** For what value of  $n$ , are the  $n$ th terms of two APs: 13, 19, 25, . . . and 69, 68, 67, . . . equal?
- Q35.** The 8<sup>th</sup> term of an AP is zero. Prove that its 38<sup>th</sup> term is triple its 18<sup>th</sup> term.
- Q36.** The 4<sup>th</sup> term of an AP is 0. Prove that its 25<sup>th</sup> term is triple its 11<sup>th</sup> term.
- Q37.** If the  $m$ th term of an AP be  $\frac{1}{n}$  and its  $n$ th term be  $\frac{1}{m}$ , then show that its  $(mn)$ th term is 1.
- Q38.** If  $m$  times the  $m$ th term of an AP is equal to  $n$  times the  $n$ th term and  $m \neq n$ , show that its  $(m + n)$ th term is 0.
- Q39.** If the  $p$ th term of an AP is  $q$  and  $q$ th term of an AP is  $p$ , prove that its  $n$ th is  $(p + q - n)$ .
- Q40.** If the  $p$ th,  $q$ th and  $r$ th terms of an AP is  $a$ ,  $b$ ,  $c$  respectively, then show that  $a(q - r) + b(r - p) + c(p - q) = 0$ .
- Q41.** If the  $p$ th,  $q$ th and  $r$ th terms of an AP is  $a$ ,  $b$ ,  $c$  respectively, then show that  $p(b - c) + q(c - a) + r(a - b) = 0$ .
- Q42.** If the  $n$ th term of a progression be a linear expression in  $n$ , then prove that this progression is an AP.
- Q43.** The sum of three numbers in AP is 21 and their product is 231. Find the numbers.

- Q44.** The sum of three numbers in AP is 27 and their product is 405. Find the numbers.
- Q45.** The sum of three numbers in AP is 15 and their product is 80. Find the numbers.
- Q46.** Find three numbers in AP whose sum is 3 and product is – 35.
- Q47.** Divide 24 in three parts such that they are in AP and their product is 440.
- Q48.** The sum of three consecutive terms of an AP is 21 and the sum of the squares of these terms is 165. Find the terms.
- Q49.** Find four numbers in AP whose sum is 20 and the sum of whose squares is 120.
- Q50.** Find four numbers in AP whose sum is 28 and the sum of whose squares is 216.
- Q51.** Find four numbers in AP whose sum is 50 and in which the greatest number is 4 times the least.
- Q52.** The angles of a quadrilateral are in AP whose common difference is  $10^0$ . Find the angles.
- Q53.** Show that  $(a - b)^2$ ,  $(a^2 + b^2)$  and  $(a + b)^2$  are in AP.
- Q54.** If 10<sup>th</sup> times the 10<sup>th</sup> term of an AP is equal to 15 times the 15<sup>th</sup> term, show that its 25<sup>th</sup> term is 0.
- Q55.** If 5 times the 5<sup>th</sup> term of an AP is equal to 8 times its 8<sup>th</sup> term, show that the 13<sup>th</sup> term is 0.
- Q56.** How many terms are there in the AP 7, 11, 15, ..... , 139?
- Q57.** How many terms are there in A.P. 7,11,15,.....139?
- Q58.** How many terms are there in the AP 6, 10, 14, 18, ..... 174.
- Q59.** How many three-digit numbers are divisible by 7?
- Q60.** How many multiples of 7 between 50 and 500?
- Q61.** How many multiples of 4 lie between 10 and 250?
- Q62.** How many terms are there in the AP 41, 38, 35, ..... , 8.
- Q63.** Which term of the AP : 3, 8, 13, 18, . . . ,is 78?
- Q64.** Which term of the A.P. 5, 13, 21, ..... is 181?
- Q65.** Which term of the A.P. 5, 9, 13, 17,..... is 81?
- Q66.** Which term of the AP 3, 8, 13, 18,..... will be 55 more than its 20<sup>th</sup> term?
- Q67.** Which term of the AP 8, 14, 20, 26,.... will be 72 more than its 41<sup>st</sup> term?
- Q68.** Which term of the AP 9, 12, 15, 18,.... will be 39 more than its 36<sup>th</sup> term?



- Q69.** Which term of the AP 3, 15, 27, 39,.... will be 120 more than its 21<sup>st</sup> term?
- Q70.** Which term of the AP 24, 21, 18, 15, .... Is first negative term?
- Q71.** Which term of the AP 3, 8, 13, 18, ..... is 88?
- Q72.** Which term of the AP 72, 68, 64, 60, ..... is 0?
- Q73.** Which term of the AP : 3, 15, 27, 39, . . . will be 132 more than its 54th term?
- Q74.** Which term of the AP  $\frac{5}{6}, 1, 1\frac{1}{6}, 1\frac{1}{3}, \dots$  is 3 ?
- Q75.** A sum of Rs. 1000 is invested at 8% simple interest per year. Calculate the interest at the end of each year. Does this interest form an AP? If so, find the interest at the end of 30 years.
- Q76.** In a flower bed, there are 23 rose plants in the first row, 21 in the second, 19 in the third, and so on. There are 5 rose plants in the last row. How many rows are there in the flower bed?
- Q77.** The sum of the 4th and 8th terms of an AP is 24 and the sum of the 6th and 10th terms is 44. Find the first three terms of the AP.
- Q78.** Manish saved Rs. 50 in the first week of the year and then increased his weekly savings by Rs. 17.50 each week. In what week will his weekly savings be Rs. 207.50?
- Q79.** Subba Rao started work in 1995 at an annual salary of Rs 5000 and received an increment of Rs 200 each year. In which year did his income reach Rs 7000?
- Q80.** Ramkali saved Rs 5 in the first week of a year and then increased her weekly savings by Rs 1.75. If in the  $n$ th week, her weekly savings become Rs 20.75, find  $n$ .
- .....

**PRACTICE QUESTIONS**  
**CLASS X : CHAPTER – 5**  
**ARITHMETIC PROGRESSIONS**  
**“SUM OF n TERMS OF AN A.P.”**

1. Find the sum of first 24 terms of the AP 5, 8, 11, 14,.....
2. Find the sum:  $25 + 28 + 31 + \dots + 100$ .
3. Find the sum of first 21 terms of the AP whose 2<sup>nd</sup> term is 8 and 4<sup>th</sup> term is 14.
4. If the nth term of an AP is  $(2n + 1)$ , find the sum of first n terms of the AP.
5. Find the sum of first 25 terms of an AP whose nth term is given by  $(7 - 3n)$ .
6. Find the sum of all two-digit odd positive numbers.
7. Find the sum of all natural number between 100 and 500 which are divisible by 8.
8. Find the sum of all three digit natural numbers which are multiples of 7.
9. How many terms of the AP 3, 5, 7, 9,... must be added to get the sum 120?
10. If the sum of first n, 2n and 3n terms of an AP be  $S_1$ ,  $S_2$  and  $S_3$  respectively, then prove that  $S_3 = 3(S_2 - S_1)$ .
11. If the sum of the first m terms of an AP be n and the sum of first n terms be m then show that the sum of its first  $(m + n)$  terms is  $-(m + n)$ .
12. If the sum of the first p terms of an AP is the same as the sum of first q terms (where  $p \neq q$ ) then show that the sum of its first  $(p + q)$  terms is 0.
13. If the pth term of an AP is  $\frac{1}{q}$  and its qth term is  $\frac{1}{p}$ , show that the sum of its first pq terms is  $\frac{1}{2}(p + q)$ .
14. Find the sum of all natural numbers less than 100 which are divisible by 6.
15. Find the sum of all natural number between 100 and 500 which are divisible by 7.
16. Find the sum of all multiples of 9 lying between 300 and 700.
17. Find the sum of all three digit natural numbers which are divisible by 13.
18. Find the sum of 51 terms of the AP whose second term is 2 and the 4<sup>th</sup> term is 8.
19. The sum of n terms of an AP is  $(5n^2 - 3n)$ . Find the AP and hence find its 10<sup>th</sup> term.

20. The first and last terms of an AP are 4 and 81 respectively. If the common difference is 7, how many terms are there in the AP and what is their sum?
21. If the sum of first 7 terms of AP is 49 and that of first 17 terms is 289, find the sum of first n terms.
22. Find the sum of the first 100 even natural numbers which are divisible by 5.
23. Find the sum of the following:  $\left(1 - \frac{1}{n}\right) + \left(1 - \frac{2}{n}\right) + \left(1 - \frac{3}{n}\right) \dots\dots\dots$  upto n terms.
24. If the 5<sup>th</sup> and 12<sup>th</sup> terms of an AP are  $-4$  and  $-18$  respectively, find the sum of first 20 terms of the AP.
25. The sum of n terms of an AP is  $\left(\frac{5n^2}{2} + \frac{3n}{2}\right)$ . Find its 20<sup>th</sup> term
26. The sum of n terms of an AP is  $\left(\frac{3n^2}{2} + \frac{5n}{2}\right)$ . Find its 25<sup>th</sup> term
27. Find the number of terms of the AP 18, 15, 12, ..... so that their sum is 45. Explain the double answer.
28. Find the number of terms of the AP 64, 60, 56, ..... so that their sum is 544. Explain the double answer.
29. Find the number of terms of the AP 17, 15, 13, ..... so that their sum is 72. Explain the double answer.
30. Find the number of terms of the AP 63, 60, 57, ..... so that their sum is 693. Explain the double answer.
31. The sum of first 9 terms of an AP is 81 and the sum of its first 20 terms is 400. Find the first term and the common difference of the AP.
32. If the nth term of an AP is  $(4n + 1)$ , find the sum of the first 15 terms of this AP. Also find the sum of is n terms.
33. The sum of the first n terms of an AP is given by  $S_n = (2n^2 + 5n)$ . Find the nth term of the AP.
34. If the sum of the first n terms of an AP is given by  $S_n = (3n^2 - n)$ , find its 20<sup>th</sup> term.
35. If the sum of the first n terms of an AP is given by  $S_n = (3n^2 + 2n)$ , find its 25<sup>th</sup> term.
36. How many terms of the AP 21, 18, 15,..... Must be added to get the sum 0?
37. Find the sum of first 24 terms whose nth term is given by  $a_n = 3 + 2n$ .
38. How many terms of the AP  $-6, \frac{-11}{2}, -5, \dots\dots\dots$  are needed to give the sum  $-25$ ? Explain the double answer.
- ~~39. Find the sum of first 24 terms of the list of numbers whose nth term is given by  $a_n = 3 + 2n$~~

40. How many terms of the AP : 24, 21, 18, . . . must be taken so that their sum is 78?
41. Find the sum of the first 40 positive integers divisible by 6.
42. Find the sum of all the two digit numbers which are divisible by 4.
43. Find the sum of all two digits natural numbers greater than 50 which, when divided by 7 leave remainder of 4.
44. If the sum of first 7 terms of an AP is 49 and that of 17 terms is 289 , find the sum of first n terms
45. If the sum of first n terms of an A.P. is given by  $S_n = 3n^2 + 5n$ , find the nth term of the A.P.
46. The sum of first 8 terms of an AP is 100 and the sum of its first 19 terms is 551. Find the AP.
47. How many terms are there in A.P. whose first terms and 6<sup>th</sup> term are -12 and 8 respectively and sum of all its terms is 120?
48. 200 logs are stacked in the following manner: 20 logs in the bottom row, 19 in the next row, 18 in the row next to it and so on. In how may rows are the 200 logs placed and how many logs are in the top row?
49. A man repays a loan of Rs. 3250 by paying Rs. 20 in the first month and then increase the payment by Rs. 15 every month. How long will it take him to clear the loan?
50. Raghav buys a shop for Rs. 1,20,000. He pays half of the amount in cash and agrees to pay the balance in 12 annual installments of Rs. 5000 each. If the rate of interest is 12% and he pays with the installment the interest due on the unpaid amount, find the total cost of the shop.
51. A sum of Rs. 280 is to be used to give four cash prizes to students of a school for their overall academic performance. If each prize is Rs. 20 less than its preceding prize, find the value of each of the prizes.
52. A sum of Rs 700 is to be used to give seven cash prizes to students of a school for their overall academic performance. If each prize is Rs 20 less than its preceding prize, find the value of each of the prizes.
53. A contract on construction job specifies a penalty for delay of completion beyond a certain date as follows: Rs 200 for the first day, Rs 250 for the second day, Rs 300 for the third day, etc., the penalty for each succeeding day being Rs 50 more than for the preceding day. How much money the contractor has to pay as penalty, if he has delayed the work by 30 days?
54. A manufacturer of TV sets produced 600 sets in the third year and 700 sets in the seventh year. Assuming that the production increases uniformly by a fixed number every year, find : (i) the production in the 1st year (ii) the production in the 10th year (iii) the total production in first 7 years
55. How many terms of the AP : 9, 17, 25, . . . must be taken to give a sum of 636?
56. The first term of an AP is 5, the last term is 45 and the sum is 400. Find the number of terms and the common difference.

57. The first and the last terms of an AP are 17 and 350 respectively. If the common difference is 9, how many terms are there and what is their sum?
58. Find the sum of first 22 terms of an AP in which  $d = 7$  and 22nd term is 149.
59. Find the sum of first 51 terms of an AP whose second and third terms are 14 and 18 respectively.
60. If the sum of first 7 terms of an AP is 49 and that of 17 terms is 289, find the sum of first  $n$  terms.
61. Show that  $a_1, a_2, \dots, a_n, \dots$  form an AP where  $a_n$  is defined as below : (i)  $a_n = 3 + 4n$  (ii)  $a_n = 9 - 5n$  Also find the sum of the first 15 terms in each case.
62. If the sum of the first  $n$  terms of an AP is  $4n - n^2$ , what is the first term (that is  $S_1$ )? What is the sum of first two terms? What is the second term? Similarly, find the 3rd, the 10th and the  $n$ th terms.
63. Find the sum of the first 15 multiples of 8.
64. Find the sum of the odd numbers between 0 and 50.
65. In a school, students thought of planting trees in and around the school to reduce air pollution. It was decided that the number of trees, that each section of each class will plant, will be the same as the class, in which they are studying, e.g., a section of Class I will plant 1 tree, a section of Class II will plant 2 trees and so on till Class XII. There are three sections of each class. How many trees will be planted by the students?
66. A spiral is made up of successive semicircles, with centres alternately at A and B, starting with centre at A, of radii 0.5 cm, 1.0 cm, 1.5 cm, 2.0 cm, . . . What is the total length of such a spiral made up of thirteen consecutive semicircles? (Take  $\pi = 22/7$ )

**CLASS X : CHAPTER - 9**  
**SOME APPLICATIONS TO TRIGONOMETRY**

**IMPORTANT FORMULAS & CONCEPTS**

**ANGLE OF ELEVATION**

In the below figure, the line AC drawn from the eye of the student to the top of the minar is called the *line of sight*. The student is looking at the top of the minar. The angle BAC, so formed by the line of sight with the horizontal, is called the *angle of elevation* of the top of the minar from the eye of the student. Thus, the **line of sight** is the line drawn from the eye of an observer to the point in the object viewed by the observer.

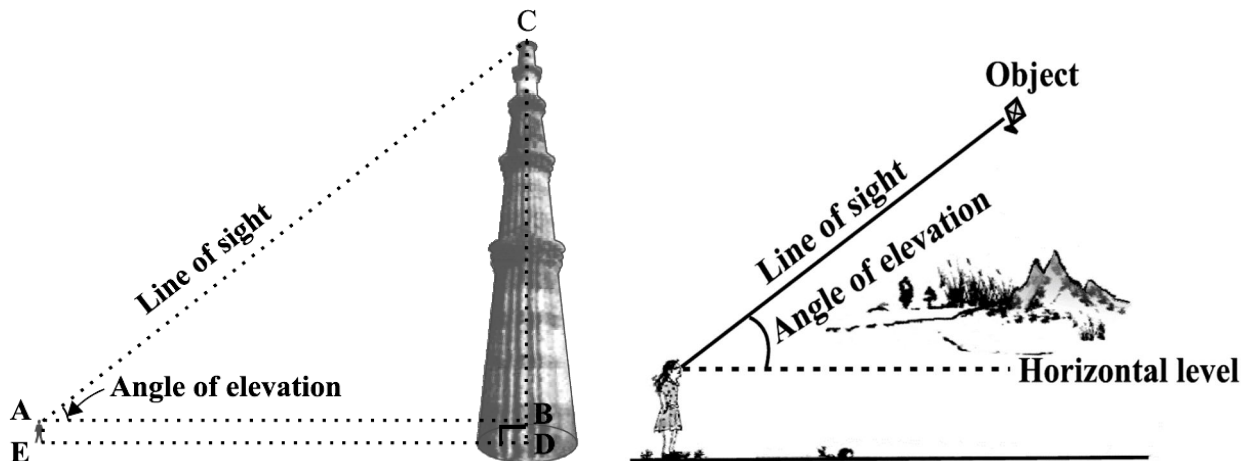

The **angle of elevation** of the point viewed is the angle formed by the line of sight with the horizontal when the point being viewed is above the horizontal level, i.e., the case when we raise our head to look at the object

**ANGLE OF DEPRESSION**

In the below figure, the girl sitting on the balcony is *looking down* at a flower pot placed on a stair of the temple. In this case, the line of sight is *below* the horizontal level. The angle so formed by the line of sight with the horizontal is called the *angle of depression*. Thus, the **angle of depression** of a point on the object being viewed is the angle formed by the line of sight with the horizontal when the point is below the horizontal level, i.e., the case when we lower our head to look at the point being viewed

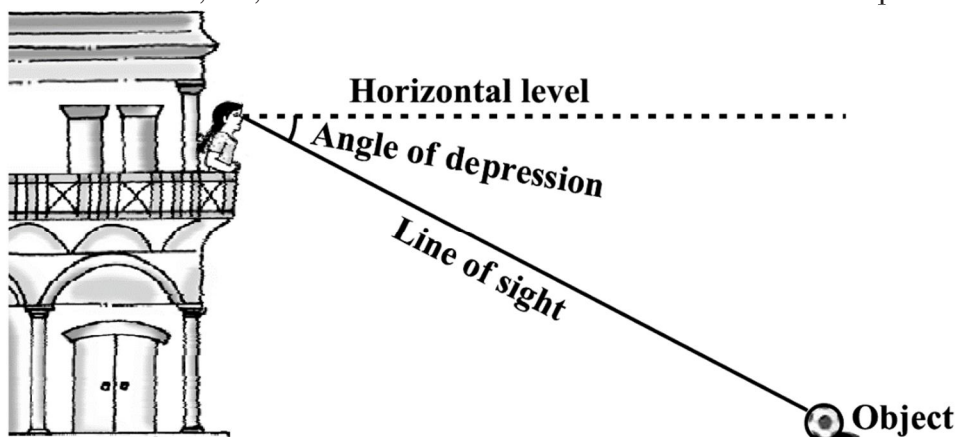

**Trigonometric Ratios (T - Ratios) of an acute angle of a right triangle**

In XOY-plane, let a revolving line OP starting from OX, trace out  $\angle XOP = \theta$ . From P (x, y) draw PM  $\perp$  OX.

In right angled triangle OMP. OM = x (Adjacent side); PM = y (opposite side); OP = r (hypotenuse).

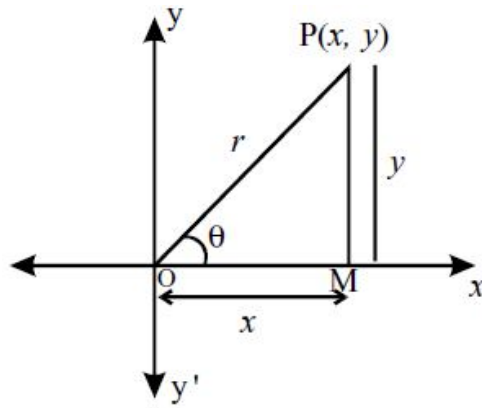

$$\sin \theta = \frac{\text{Opposite Side}}{\text{Hypotenuse}} = \frac{y}{r}, \quad \cos \theta = \frac{\text{Adjacent Side}}{\text{Hypotenuse}} = \frac{x}{r}, \quad \tan \theta = \frac{\text{Opposite Side}}{\text{Adjacent Side}} = \frac{y}{x}$$

$$\operatorname{cosec} \theta = \frac{\text{Hypotenuse}}{\text{Opposite Side}} = \frac{r}{y}, \quad \sec \theta = \frac{\text{Hypotenuse}}{\text{Adjacent Side}} = \frac{r}{x}, \quad \cot \theta = \frac{\text{Adjacent Side}}{\text{Opposite Side}} = \frac{x}{y}$$

### Reciprocal Relations

$$\operatorname{cosec} \theta = \frac{1}{\sin \theta}, \quad \sec \theta = \frac{1}{\cos \theta} \quad \text{and} \quad \cot \theta = \frac{1}{\tan \theta}$$

### Quotient Relations

$$\tan \theta = \frac{\sin \theta}{\cos \theta} \quad \text{and} \quad \cot \theta = \frac{\cos \theta}{\sin \theta}$$

### Trigonometric ratios of Complementary angles.

$$\begin{aligned} \sin(90 - \theta) &= \cos \theta & \cos(90 - \theta) &= \sin \theta \\ \tan(90 - \theta) &= \cot \theta & \cot(90 - \theta) &= \tan \theta \\ \sec(90 - \theta) &= \operatorname{cosec} \theta & \operatorname{cosec}(90 - \theta) &= \sec \theta. \end{aligned}$$

### Trigonometric ratios for angle of measure.

$0^\circ, 30^\circ, 45^\circ, 60^\circ$  and  $90^\circ$  in tabular form.

$\angle A$	$0^\circ$	$30^\circ$	$45^\circ$	$60^\circ$	$90^\circ$
<b>sinA</b>	0	$\frac{1}{2}$	$\frac{1}{\sqrt{2}}$	$\frac{\sqrt{3}}{2}$	1
<b>cosA</b>	1	$\frac{\sqrt{3}}{2}$	$\frac{1}{\sqrt{2}}$	$\frac{1}{2}$	0
<b>tanA</b>	0	$\frac{1}{\sqrt{3}}$	1	$\sqrt{3}$	Not defined
<b>cosecA</b>	Not defined	2	$\sqrt{2}$	$\frac{2}{\sqrt{3}}$	1
<b>secA</b>	1	$\frac{2}{\sqrt{3}}$	$\sqrt{2}$	2	Not defined
<b>cotA</b>	Not defined	$\sqrt{3}$	1	$\frac{1}{\sqrt{3}}$	0

**MCQ WORKSHEET-I**  
**CLASS X: CHAPTER – 9**  
**SOME APPLICATIONS TO TRIGONOMETRY**

1. The angle of elevation of the top of a tower from a point on the ground, which is 20m away from the foot of the tower is  $60^\circ$ . Find the height of the tower.  
 (a)  $10\sqrt{3}$  m      (b)  $30\sqrt{3}$  m      (c)  $20\sqrt{3}$  m      (d) none of these
2. The height of a tower is 10m. What is the length of its shadow when Sun's altitude is  $45^\circ$ ?  
 (a) 10 m      (b) 30 m      (c) 20 m      (d) none of these
3. The angle of elevation of a ladder leaning against a wall is  $60^\circ$  and the foot of the ladder is 9.5 m away from the wall. Find the length of the ladder.  
 (a) 10 m      (b) 19 m      (c) 20 m      (d) none of these
4. If the ratio of the height of a tower and the length of its shadow is  $\sqrt{3} : 1$ , what is the angle of elevation of the Sun?  
 (a)  $30^\circ$       (b)  $60^\circ$       (c)  $45^\circ$       (d) none of these
5. What is the angle of elevation of the Sun when the length of the shadow of a vertical pole is equal to its height?  
 (a)  $30^\circ$       (b)  $60^\circ$       (c)  $45^\circ$       (d) none of these
6. From a point on the ground, 20 m away from the foot of a vertical tower, the angle of elevation of the top of the tower is  $60^\circ$ , what is the height of the tower?  
 (a)  $10\sqrt{3}$  m      (b)  $30\sqrt{3}$  m      (c)  $20\sqrt{3}$  m      (d) none of these
7. If the angles of elevation of the top of a tower from two points at a distance of 4 m and 9 m from the base of the tower and in the same straight line with it are complementary, find the height of the tower.  
 (a) 10 m      (b) 6 m      (c) 8 m      (d) none of these
8. In the below fig. what are the angles of depression from the observing positions D and E of the object A?  
 (a)  $30^\circ, 45^\circ$       (b)  $60^\circ, 45^\circ$       (c)  $45^\circ, 60^\circ$       (d) none of these

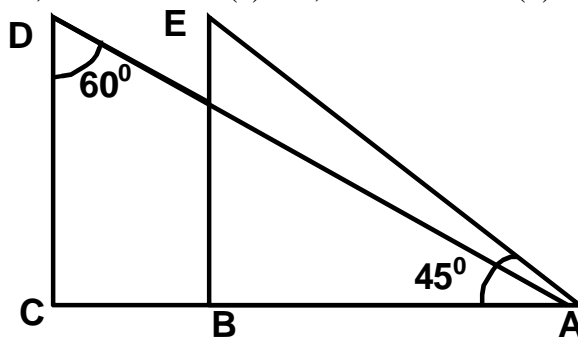

9. The ratio of the length of a rod and its shadow is  $1 : \sqrt{3}$ . The angle of elevation of the sun is  
 (a)  $30^\circ$       (b)  $60^\circ$       (c)  $45^\circ$       (d) none of these
10. If the angle of elevation of a tower from a distance of 100m from its foot is  $60^\circ$ , then the height of the tower is  
 (a)  $100\sqrt{3}$  m      (b)  $\frac{200}{\sqrt{3}}$  m      (c)  $50\sqrt{3}$  m      (d)  $\frac{100}{\sqrt{3}}$  m



**MCQ WORKSHEET-II**  
**CLASS X: CHAPTER – 9**  
**SOME APPLICATIONS TO TRIGONOMETRY**

1. If the altitude of the sun is at  $60^\circ$ , then the height of the vertical tower that will cast a shadow of length 30m is  
(a)  $30\sqrt{3}$  m      (b) 15 m      (c)  $\frac{30}{\sqrt{3}}$  m      (d)  $15\sqrt{2}$  m
2. A tower subtends an angle of  $30^\circ$  at a point on the same level as its foot. At a second point 'h' metres above the first, the depression of the foot of the tower is  $60^\circ$ . The height of the tower is  
(a)  $\frac{h}{2}$  m      (b)  $\frac{h}{3}$  m      (c)  $\sqrt{3}h$  m      (d)  $\frac{h}{\sqrt{3}}$  m
3. A tower is  $100\sqrt{3}$  m high. Find the angle of elevation if its top from a point 100 m away from its foot.  
(a)  $30^\circ$       (b)  $60^\circ$       (c)  $45^\circ$       (d) none of these
4. The angle of elevation of the top of a tower from a point on the ground, which is 30m away from the foot of the tower is  $30^\circ$ . Find the height of the tower.  
(a)  $10\sqrt{3}$  m      (b)  $30\sqrt{3}$  m      (c)  $20\sqrt{3}$  m      (d) none of these
5. The string of a kite is 100m long and it makes an angle of  $60^\circ$  with the horizontal. Find the height of the kite, assuming that there is no slack in the string.  
(a)  $100\sqrt{3}$  m      (b)  $\frac{200}{\sqrt{3}}$  m      (c)  $50\sqrt{3}$  m      (d)  $\frac{100}{\sqrt{3}}$  m
6. A kite is flying at a height of 60m above the ground. The inclination of the string with the ground is  $60^\circ$ . Find the length of the string, assuming that there is no slack in the string.  
(a)  $40\sqrt{3}$  m      (b)  $30\sqrt{3}$  m      (c)  $20\sqrt{3}$  m      (d) none of these
7. A circus artist is climbing a 20m long rope, which is tightly stretched and tied from the top of a vertical pole to the ground. Find the height of the pole if the angle made by the rope with the ground level is  $30^\circ$ .  
(a) 10 m      (b) 30 m      (c) 20 m      (d) none of these
8. A tower is 50m high, Its shadow is 'x' metres shorter when the sun's altitude is  $45^\circ$  than when it is  $30^\circ$ . Find the value of 'x'  
(a)  $100\sqrt{3}$  m      (b)  $\frac{200}{\sqrt{3}}$  m      (c)  $50\sqrt{3}$  m      (d) none of these
9. Find the angular elevation of the sun when the shadow of a 10m long pole is  $10\sqrt{3}$  m.  
(a)  $30^\circ$       (b)  $60^\circ$       (c)  $45^\circ$       (d) none of these
10. A vertical pole stands on the level ground. From a point on the ground 25m away from the foot of the pole, the angle of elevation of its top is found to be  $60^\circ$ . Find the height of the pole.  
(a)  $25\sqrt{3}$  m      (b)  $\frac{25}{\sqrt{3}}$  m      (c)  $50\sqrt{3}$  m      (d) none of these

**MCQ WORKSHEET-III**  
**CLASS X: CHAPTER – 9**  
**SOME APPLICATIONS TO TRIGONOMETRY**

1. A kite is flying at a height of 75m above the ground. The inclination of the string with the ground is  $60^\circ$ . Find the length of the string, assuming that there is no slack in the string.  
(a)  $40\sqrt{3}$  m      (b)  $30\sqrt{3}$  m      (c)  $50\sqrt{3}$  m      (d) none of these
2. The angle of elevation of the top of a tree from a point A on the ground is  $60^\circ$ . On walking 20m away from its base, to a point B, the angle of elevation changes to  $30^\circ$ . Find the height of the tree.  
(a)  $10\sqrt{3}$  m      (b)  $30\sqrt{3}$  m      (c)  $20\sqrt{3}$  m      (d) none of these
3. A 1.5m tall boy stands at a distance of 2m from lamp post and casts a shadow of 4.5m on the ground. Find the height of the lamp post.  
(a) 3 m      (b) 2.5 m      (c) 5 m      (d) none of these
4. The height of the tower is 100m. When the angle of elevation of the sun changes from  $30^\circ$  to  $45^\circ$ , the shadow of the tower becomes 'x' meters less. The value of 'x' is  
(a)  $100\sqrt{3}$  m      (b) 100 m      (c)  $100(\sqrt{3} - 1)$  m      (d)  $\frac{100}{\sqrt{3}}$
5. The tops of two poles of height 20m and 14m are connected by a wire. If the wire makes an angle of  $30^\circ$  with horizontal, then the length of the wire is  
(a) 12 m      (b) 10 m      (c) 8 m      (d) 6 m
6. If the angles of elevation of a tower from two points distant a and b ( $a > b$ ) from its foot and in the same straight line from it are  $30^\circ$  and  $60^\circ$ , then the height of the tower is  
(a)  $\sqrt{a+b}$  m      (b)  $\sqrt{a-b}$  m      (c)  $\sqrt{ab}$  m      (d)  $\sqrt{\frac{a}{b}}$  m
7. The angles of elevation of the top of a tower from two points at a distance of 'a' m and 'b' m from the base of the tower and in the same straight line with it are complementary, then the height of the tower is  
(a)  $\sqrt{a+b}$  m      (b)  $\sqrt{a-b}$  m      (c)  $\sqrt{ab}$  m      (d)  $\sqrt{\frac{a}{b}}$  m
8. From the top of a cliff 25m high the angle of elevation of a tower is found to be equal to the angle of depression of the foot of the tower. The height of the tower is  
(a) 25 m      (b) 50 m      (c) 75 m      (d) 100 m
9. If the angle of elevation of a cloud from a point 200m above a lake is  $30^\circ$  and the angle of depression of its reflection in the lake is  $60^\circ$ , then the height of the cloud above the lake is  
(a) 200 m      (b) 500 m      (c) 30 m      (d) 400 m
10. The angle of elevation of a cloud from a point 'h' meter above a lake is ' $\alpha$ '. The angle of depression of its reflection in the lake is  $45^\circ$ . The height of the cloud is  
(a)  $h \cdot \tan \alpha$       (b)  $\frac{h(1 + \tan \alpha)}{(1 - \tan \alpha)}$       (c)  $\frac{h(1 - \tan \alpha)}{(1 + \tan \alpha)}$       (d) none of these

**PRACTICE QUESTIONS**  
**CLASS X: CHAPTER – 9**  
**SOME APPLICATIONS TO TRIGONOMETRY**

1. A vertical stick 10 cm long casts a shadow 8 cm long. At the same time, a tower casts a shadow 30 m long. Determine the height of the tower.
2. An observer, 1.5 m tall, is 28.5 m away from a tower 30 m high. Find the angle of elevation of the top of the tower from his eye.
3. A person standing on the bank of a river observes that the angle subtended by a tree on the opposite bank is  $60^\circ$ . When he retreats 20m from the bank, he finds the angle to be  $30^\circ$ . Find the height of the tree and the breadth of the river.
4. A boy is standing on ground and flying a kite with 150m of string at an elevation of  $30^\circ$ . Another boy is standing on the roof of a 25m high building and flying a kite at an elevation of  $45^\circ$ . Find the length of string required by the second boy so that the two kites just meet, if both the boys are on opposite side of the kites.
5. An aeroplane flying horizontally 1000m above the ground, is observed at an angle of elevation  $60^\circ$  from a point on the ground. After a flight of 10 seconds, the angle of elevation at the point of observation changes to  $30^\circ$ . Find the speed of the plane in m/s.
6. An aeroplane when flying at a height of 4000 m from the ground passes vertically above another aeroplane at an instant when the angles of the elevation of the two planes from the same point on the ground are  $60^\circ$  and  $45^\circ$  respectively. Find the vertical distance between the aeroplanes at that instant.
7. An aeroplane at an altitude of 200 m observes the angles of depression of opposite points on the two banks of a river to be  $45^\circ$  and  $60^\circ$ . Find the width of the river.
8. The shadow of a flag staff is three times as long as the shadow of the flag staff when the sun rays meet the ground at an angle of  $60^\circ$ . Find the angle between the sun rays and the ground at the time of longer shadow.
9. A vertically straight tree, 15m high is broken by the wind in such a way that its top just touches the ground and makes an angle of  $60^\circ$  with the ground, at what height from the ground did the tree break?
10. A man in a boat rowing away from lighthouse 100 m high takes 2 minutes to change the angle of elevation of the top of lighthouse from  $60^\circ$  to  $45^\circ$ . Find the speed of the boat.
11. As observed from the top of a light house, 100m above sea level, the angle of depression of ship, sailing directly towards it, changes from  $30^\circ$  to  $45^\circ$ . Determine the distance travelled by the ship during the period of observation.
12. A man standing on the deck of ship, which is 10m above the water level, observes the angle of elevation of the top of a hill as  $60^\circ$  and the angle of depression of the base of the hill as  $30^\circ$ . Calculate the distance of the hill from the ship and the height of the hill.

13. The angles of elevation of the top of a tower from two points at a distance of 'a' m and 'b' m from the base of the tower and in the same straight line with it are complementary, then prove that the height of the tower is  $\sqrt{a.b}$
14. A tower stands vertically on the ground. From a point on the ground, which is 15 m away from the foot of the tower, the angle of elevation of the top of the tower is found to be  $60^\circ$ . Find the height of the tower.
15. An electrician has to repair an electric fault on a pole of height 5 m. She needs to reach a point 1.3m below the top of the pole to undertake the repair work. What should be the length of the ladder that she should use which, when inclined at an angle of  $60^\circ$  to the horizontal, would enable her to reach the required position? Also, how far from the foot of the pole should she place the foot of the ladder? (You may take  $\sqrt{3} = 1.73$ )
16. An observer 1.5 m tall is 28.5 m away from a chimney. The angle of elevation of the top of the chimney from her eyes is  $45^\circ$ . What is the height of the chimney?
17. From a point P on the ground the angle of elevation of the top of a 10 m tall building is  $30^\circ$ . A flag is hoisted at the top of the building and the angle of elevation of the top of the flagstaff from P is  $45^\circ$ . Find the length of the flagstaff and the distance of the building from the point P. (You may take  $\sqrt{3} = 1.73$ )
18. The shadow of a tower standing on a level ground is found to be 40 m longer when the Sun's altitude is  $30^\circ$  than when it is  $60^\circ$ . Find the height of the tower.
19. The angles of depression of the top and the bottom of an 8 m tall building from the top of a multi-storeyed building are  $30^\circ$  and  $45^\circ$ , respectively. Find the height of the multi-storeyed building and the distance between the two buildings.
20. From a point on a bridge across a river, the angles of depression of the banks on opposite sides of the river are  $30^\circ$  and  $45^\circ$ , respectively. If the bridge is at a height of 3 m from the banks, find the width of the river.
21. A 1.5 m tall boy is standing at some distance from a 30 m tall building. The angle of elevation from his eyes to the top of the building increases from  $30^\circ$  to  $60^\circ$  as he walks towards the building. Find the distance he walked towards the building.
22. From a point on the ground, the angles of elevation of the bottom and the top of a transmission tower fixed at the top of a 20 m high building are  $45^\circ$  and  $60^\circ$  respectively. Find the height of the tower.
23. A statue, 1.6 m tall, stands on the top of a pedestal. From a point on the ground, the angle of elevation of the top of the statue is  $60^\circ$  and from the same point the angle of elevation of the top of the pedestal is  $45^\circ$ . Find the height of the pedestal.
24. The angle of elevation of the top of a building from the foot of the tower is  $30^\circ$  and the angle of elevation of the top of the tower from the foot of the building is  $60^\circ$ . If the tower is 50 m high, find the height of the building.
25. A 1.2 m tall girl spots a balloon moving with the wind in a horizontal line at a height of 88.2 m from the ground. The angle of elevation of the balloon from the eyes of the girl at any instant is  $60^\circ$ . After some time, the angle of elevation reduces to  $30^\circ$ . Find the distance travelled by the balloon during the interval.

26. A straight highway leads to the foot of a tower. A man standing at the top of the tower observes a car at an angle of depression of  $30^\circ$ , which is approaching the foot of the tower with a uniform speed. Six seconds later, the angle of depression of the car is found to be  $60^\circ$ . Find the time taken by the car to reach the foot of the tower from this point.
27. A man on cliff observes a boat an angle of depression of  $30^\circ$  which is approaching the shore to the point immediately beneath the observer with a uniform speed. Six minutes later, the angle of depression of the boat is found to be  $60^\circ$ . Find the time taken by the boat to reach the shore.
28. The angles of elevation of the top of a tower from two points at a distance of 4 m and 9 m from the base of the tower and in the same straight line with it are complementary. Prove that the height of the tower is 6 m.
29. A tree breaks due to storm and the broken part bends so that the top of the tree touches the ground making an angle  $30^\circ$  with it. The distance between the foot of the tree to the point where the top touches the ground is 8 m. Find the height of the tree.
30. A tree is broken by the storm. The top of the tree touches the ground making an angle  $30^\circ$  and at a distance of 30 m from the root. Find the height of the tree.
31. A tree 12m high, is broken by the storm. The top of the tree touches the ground making an angle  $60^\circ$ . At what height from the bottom the tree is broken by the storm.
32. At a point on level ground, the angle of elevation of a vertical tower is found to be such that its tangent is  $\frac{5}{12}$ . In walking 192 m towards the tower, the tangent of the angle of elevation is  $\frac{3}{4}$ . Find the height of the tower.
33. The pilot of an aircraft flying horizontally at a speed of 1200km/hr, observes that the angle of depression of a point on the ground changes from  $30^\circ$  to  $45^\circ$  in 15 seconds. Find the height at which the aircraft is flying.
34. If the angle of elevation of the cloud from a point h m above a lake is A and the angle of depression of its reflection in the lake is B, prove that the height of the cloud is  $\frac{h(\tan B + \tan A)}{(\tan B - \tan A)}$
35. The angle of elevation of cloud from a point 120m above a lake is  $30^\circ$  and the angle of depression of the reflection of the cloud in the lake is  $60^\circ$ . Find the height of the cloud.
36. The angle of elevation of cloud from a point 60m above a lake is  $30^\circ$  and the angle of depression of the reflection of the cloud in the lake is  $60^\circ$ . Find the height of the cloud.
37. The angle of elevation of a jet plane from a point A on the ground is  $60^\circ$ . After a flight of 15 seconds, the angle of elevation changes to  $30^\circ$ . If the jet plane is flying at a constant height of  $1500\sqrt{3}$  m, find the speed of the jet plane.
38. The angle of elevation of a jet plane from a point A on the ground is  $60^\circ$ . After a flight of 30 seconds, the angle of elevation changes to  $30^\circ$ . If the jet plane is flying at a constant height of  $3600\sqrt{3}$  m, find the speed of the jet plane.
39. There are two temples, one on each bank of river, just opposite to each other. One temple is 50m high. From the top of this temple, the angles of depression of the top and foot of the other temple are  $30^\circ$  and  $60^\circ$  respectively. Find the width of the river and the height of other temple.

40. A ladder rests against a wall at an angle  $\alpha$  to the horizontal, its foot is pulled away from the wall through a distant  $a$ , so that it slides a distance  $b$  down the wall making an angle  $\beta$  with the horizontal. Show that  $\frac{a}{b} = \frac{\cos \alpha - \cos \beta}{\sin \beta - \sin \alpha}$ .
41. From a window,  $h$  meter above the ground of a house in a street, the angle of elevation and depression of the top and the foot of another house on the opposite side of the street are  $\theta$  and  $\phi$  respectively. Show that the height of the opposite house is  $h(1 + \tan \theta \cot \phi)$ .
42. From a window, 15 meters high above the ground of a house in a street, the angle of elevation and depression of the top and the foot of another house on the opposite side of the street are  $30^\circ$  and  $45^\circ$  respectively. Find the height of the opposite house.
43. Two stations due south of a leaning tower which leans towards the north are at distances  $a$  and  $b$  from its foot. If  $\alpha$  and  $\beta$  are the elevations of the top of the tower from these stations, prove that its inclination  $\theta$  to the horizontal is given by  $\cot \theta = \frac{b \cot \alpha - a \cot \beta}{b - a}$ .
44. The angle of elevation of a cliff from a fixed point is  $\theta$ . After going up a distance of ' $k$ ' meters towards the top of the cliff at an angle of  $\phi$ , it is found that the angle of elevation is  $\alpha$ . Show that the height of the cliff is  $\frac{k(\cos \phi - \sin \phi \cdot \cot \alpha)}{\cot \theta - \cot \alpha}$ .
45. A round balloon of radius  $r$  subtends an angle  $\alpha$  at the eye of the observer while the angle of elevation of its centre is  $\beta$ . Prove that the height of the centre of the balloon is  $r \sin \beta \cdot \operatorname{cosec} \frac{\alpha}{2}$ .
46. The angle of elevation of the top of a tower from a point on the same level as the foot of the tower is  $\alpha$ . On advancing ' $p$ ' meters towards the foot of the tower the angle of elevation becomes  $\beta$ . Show that the height ' $h$ ' of the tower is given by  $h = \left( \frac{p \tan \alpha \tan \beta}{\tan \beta - \tan \alpha} \right)$  m. Also determine the height of the tower if  $p = 150$  m,  $\alpha = 30^\circ$  and  $\beta = 60^\circ$ .
47. From the top of a light-house the angle of depression of two ships on the opposite sides of it are observed to be  $\alpha$  and  $\beta$ . If the height of the light-house be ' $h$ ' meter and the line joining the ships passes through the foot of the light house, show that the distance between the ships is  $h \left( \frac{\tan \alpha + \tan \beta}{\tan \alpha \cdot \tan \beta} \right)$  meters.
48. An electrician has to repair an electric fault on a pole of height 4m. she needs to reach a point 1.3m below the top of the pole to undertake the repair work. What should be the height of the ladder that she should use at angle of  $60^\circ$  to the horizontal, would enable her reach the required position? Also, how far the foot of the pole should she place the foot of the ladder. (take  $\sqrt{3} = 1.732$ )
49. The angle of elevation of a jet fighter from a point A on the ground is  $60^\circ$ . After a flight of 15 sec, the angle of elevation changes to  $30^\circ$ . If the jet is flying at a speed of 720 km/hr, find the constant height at which the jet is flying.
50. A man on a top of a tower observes a truck at angle of depression  $\alpha$  where  $\tan \alpha = \frac{1}{\sqrt{5}}$  and sees that it is moving towards the base of the tower. Ten minutes later, the angle of depression of truck found to be  $\beta$  where  $\tan \beta = \sqrt{5}$  if the truck is moving at uniform speed determine how much more time it will take to reach the base of the tower.

51. At the foot of a mountain the elevation of its summit is  $45^{\circ}$ ; after ascending 1000m towards the mountain up a slope of  $30^{\circ}$  inclination, the elevation is found to be  $60^{\circ}$ . Find the height of the mountain.
52. If the angle of elevation of cloud from a point  $h$  metres above a lake is  $\alpha$  and the angle of depression of its reflection in the lake be  $\beta$ , prove that the distance of the cloud from the point of observation is  $\frac{2h \sec \alpha}{\tan \beta - \tan \alpha}$ .
53. A vertical tower stands on a horizontal plane and is surmounted by a vertical flag staff of height 'h'. At a point on the plane, the angles of elevation of the bottom and top of the flag staff are  $\alpha$  and  $\beta$  respectively. Prove that the height of the tower is  $\frac{h \tan \alpha}{\tan \beta - \tan \alpha}$ .
54. A man on the top of a vertical tower observes a car moving at a uniform speed coming directly towards it. If it takes 12 minutes for the angle of depression to change from  $30^{\circ}$  to  $45^{\circ}$ , how soon after this, will the car reach the tower? Give your answer to the nearest second.
55. Two pillars of equal height and on either side of a road, which is 100m wide. The angles of depression of the top of the pillars are  $60^{\circ}$  and  $30^{\circ}$  at a point on the road between the pillars. Find the position of the point between the pillars and the height of the tower.
56. The angle of elevation of the top of a tower from a point A due north of the tower is  $\alpha$  and from B due west of the tower is  $\beta$ . If  $AB = d$ , show that the height of the tower is  $\frac{d \sin \alpha \sin \beta}{\sqrt{\sin^2 \alpha - \sin^2 \beta}}$ .
57. The angle of elevation of the top of a tower from a point A due south of the tower is  $\alpha$  and from B due east of the tower is  $\beta$ . If  $AB = d$ , show that the height of the tower is  $\frac{d}{\sqrt{\cot^2 \alpha + \cot^2 \beta}}$ .
58. From an aeroplane vertically above a straight horizontal road, the angles of depression of two consecutive milestones on opposite sides of the aeroplane are observed to be  $\alpha$  and  $\beta$ . Show that the height in miles of aeroplane above the road is given by  $\frac{\tan \alpha \tan \beta}{\tan \alpha + \tan \beta}$ .
59. A tree standing on horizontal plane is leaning towards east. At two points situated at distances  $a$  and  $b$  exactly due west on it, angles of elevation of the top are respectively  $\alpha$  and  $\beta$ . Prove that the height of the top from the ground is  $\frac{(b-a) \tan \alpha \tan \beta}{\tan \alpha - \tan \beta}$ .
60. The length of the shadow of a tower standing on level plane is found to be  $2x$  metres longer when the sun's altitude is  $30^{\circ}$  than when it was  $45^{\circ}$ . Prove that the height of tower is  $x(\sqrt{3} + 1)m$ .
- .....

**CLASS X : CHAPTER - 10**  
**CIRCLES**

**IMPORTANT FORMULAS & CONCEPTS**

**Circle**

The collection of all the points in a plane, which are at a fixed distance from a fixed point in the plane, is called a circle.

- The fixed point is called the *centre* of the circle and the fixed distance is called the *radius* of the circle. In the below figure, O is the centre and the length OP is the radius of the circle.

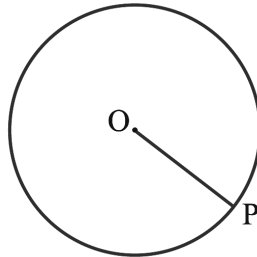

- The line segment joining the centre and any point on the circle is also called a *radius* of the circle.
- A circle divides the plane on which it lies into three parts. They are: (i) inside the circle, which is also called the *interior* of the circle; (ii) the *circle* and (iii) outside the circle, which is also called the *exterior* of the circle. The circle and its interior make up the *circular region*.
- The chord is the line segment having its two end points lying on the circumference of the circle.
- The chord, which passes through the centre of the circle, is called a *diameter* of the circle.
- A *diameter is the longest chord and all diameters have the same length, which is equal to two times the radius.*
- A piece of a circle between two points is called an *arc*.
- The longer one is called the *major arc* PQ and the shorter one is called the *minor arc* PQ.
- The length of the complete circle is called its *circumference*.
- The region between a chord and either of its arcs is called a *segment* of the circular region or simply a *segment* of the circle. There are two types of segments also, which are the *major segment* and the *minor segment*.
- The region between an arc and the two radii, joining the centre to the end points of the arc is called a *sector*. The minor arc corresponds to the *minor sector* and the major arc corresponds to the *major sector*.
- In the below figure, the region OPQ is the minor sector and remaining part of the circular region is the major sector. When two arcs are equal, that is, each is a semicircle, then both segments and both sectors become the same and each is known as a *semicircular region*.



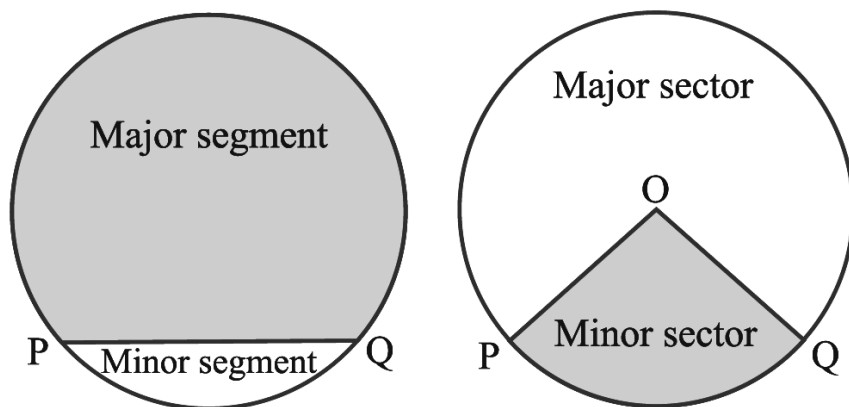

### Points to Remember :

- A circle is a collection of all the points in a plane, which are equidistant from a fixed point in the plane.
- Equal chords of a circle (or of congruent circles) subtend equal angles at the centre.
- If the angles subtended by two chords of a circle (or of congruent circles) at the centre (corresponding centre) are equal, the chords are equal.
- The perpendicular from the centre of a circle to a chord bisects the chord.
- The line drawn through the centre of a circle to bisect a chord is perpendicular to the chord.
- There is one and only one circle passing through three non-collinear points.
- Equal chords of a circle (or of congruent circles) are equidistant from the centre (or corresponding centres).
- Chords equidistant from the centre (or corresponding centres) of a circle (or of congruent circles) are equal.
- If two arcs of a circle are congruent, then their corresponding chords are equal and conversely, if two chords of a circle are equal, then their corresponding arcs (minor, major) are congruent.
- Congruent arcs of a circle subtend equal angles at the centre.
- The angle subtended by an arc at the centre is double the angle subtended by it at any point on the remaining part of the circle.
- Angles in the same segment of a circle are equal.
- Angle in a semicircle is a right angle.
- If a line segment joining two points subtends equal angles at two other points lying on the same side of the line containing the line segment, the four points lie on a circle.
- The sum of either pair of opposite angles of a cyclic quadrilateral is  $180^\circ$ .
- If the sum of a pair of opposite angles of a quadrilateral is  $180^\circ$ , then the quadrilateral is cyclic.

### Secant to a Circle

A secant to a circle is a line that intersects the circle at exactly two points.

### Tangent to a Circle

**A tangent to a circle is a line that intersects the circle at only one point.**

Given two circles, there are lines that are tangents to both of them at the same time.

☞ If the circles are separate (do not intersect), there are four possible common tangents:

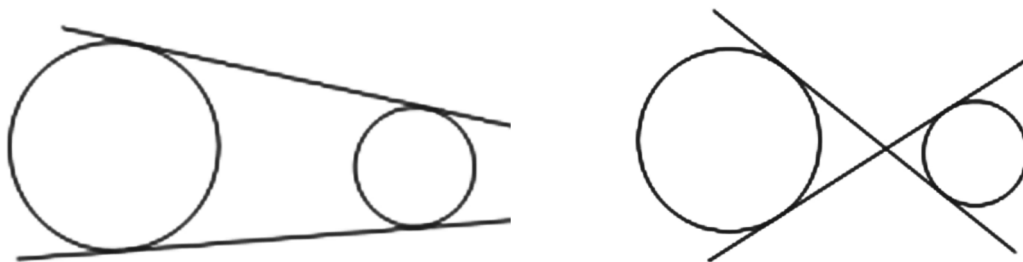

☞ If the two circles touch at just one point, there are three possible tangent lines that are common to both:

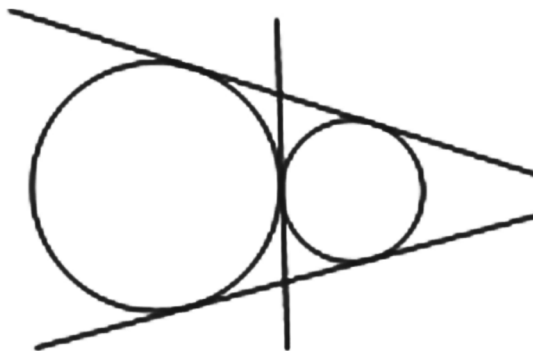

☞ If the two circles touch at just one point, with one inside the other, there is just one line that is a tangent to both:

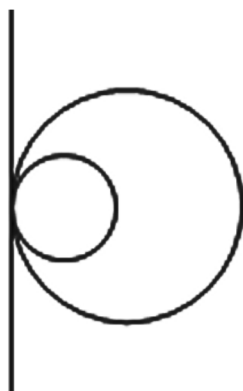

☞ If the circles overlap - i.e. intersect at two points, there are two tangents that are common to both:

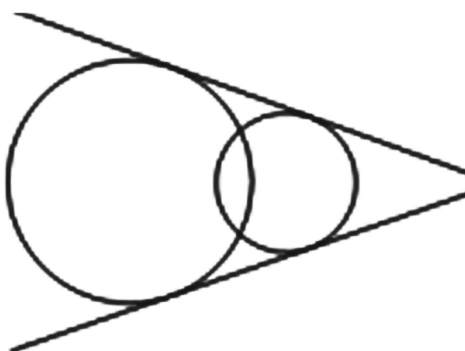

☞ If the circles lie one inside the other, there are no tangents that are common to both. A tangent to the inner circle would be a secant of the outer circle.

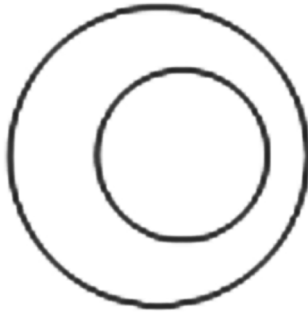

- ☞ The tangent to a circle is perpendicular to the radius through the point of contact.
- ☞ *The lengths of tangents drawn from an external point to a circle are equal.*
- ☞ The centre lies on the bisector of the angle between the two tangents.
- ☞ “If a line in the plane of a circle is perpendicular to the radius at its endpoint on the circle, then the line is tangent to the circle”.



**MCQ WORKSHEET-I**  
**CLASS X: CHAPTER – 10**  
**CIRCLES**

- Find the length of tangent drawn to a circle with radius 7 cm from a point 25 cm away from the centre.  
 (a) 24 cm      (b) 27 cm      (c) 26 cm      (d) 25 cm
- A point P is 26 cm away from the centre of a circle and the length of the tangent drawn from P to the circle is 24 cm. Find the radius of the circle.  
 (a) 11 cm      (b) 10 cm      (c) 16 cm      (d) 15 cm
- From an external point P, tangents PA and PB are drawn to a circle with centre O. If CD is the tangent to the circle at a point E and PA = 14 cm, find the perimeter of the  $\Delta PCD$ .  
 (a) 28 cm      (b) 27 cm      (c) 26 cm      (d) 25 cm

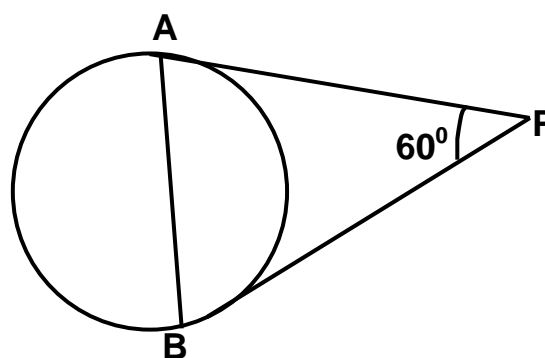
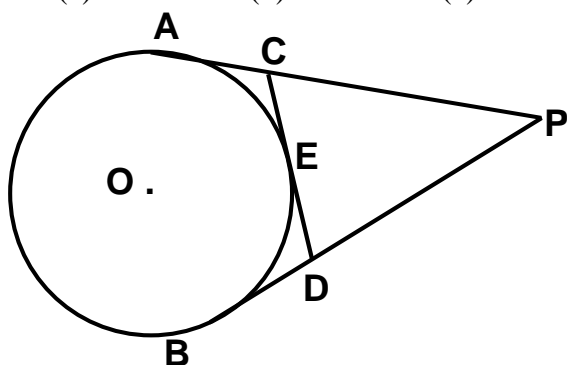

- In the above sided figure, PA and PB are tangents such that PA = 9cm and  $\angle APB = 60^\circ$ . Find the length of the chord AB.  
 (a) 4 cm      (b) 7 cm      (c) 6 cm      (d) 9 cm
- In the below figure the circle touches all the sides of a quadrilateral ABCD whose three sides are AB = 6 cm, BC = 7 cm, CD = 4 cm. Find AD.  
 (a) 4 cm      (b) 3 cm      (c) 6 cm      (d) 9 cm

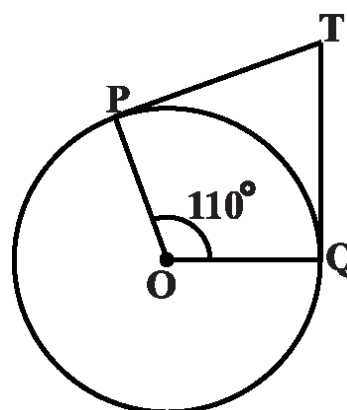
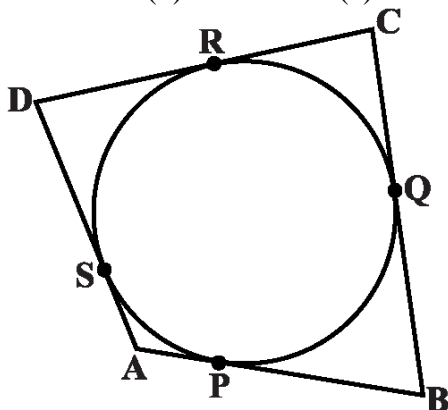

- In the above sided Fig., if TP and TQ are the two tangents to a circle with centre O so that  $\angle POQ = 110^\circ$ , then  $\angle PTQ$  is equal to  
 (a)  $60^\circ$       (b)  $70^\circ$       (c)  $80^\circ$       (d)  $90^\circ$
- If tangents PA and PB from a point P to a circle with centre O are inclined to each other at angle of  $80^\circ$ , then  $\angle POA$  is equal to  
 (a)  $60^\circ$       (b)  $70^\circ$       (c)  $80^\circ$       (d)  $50^\circ$

8. The length of a tangent from a point A at distance 5 cm from the centre of the circle is 4 cm. Find the radius of the circle.  
 (a) 4 cm      (b) 3 cm      (c) 6 cm      (d) 5 cm
9. From a point P, 10 cm away from the centre of a circle, a tangent PT of length 8 cm is drawn. Find the radius of the circle.  
 (a) 4 cm      (b) 7 cm      (c) 6 cm      (d) 5 cm
10. PT is tangent to a circle with centre O,  $OT = 56$  cm,  $TP = 90$  cm, find OP  
 (a) 104 cm      (b) 107 cm      (c) 106 cm      (d) 105 cm
11. TP and TQ are the two tangents to a circle with center O so that angle  $\angle POQ = 130^\circ$ . Find  $\angle PTQ$ .  
 (a)  $50^\circ$       (b)  $70^\circ$       (c)  $80^\circ$       (d) none of these
12. From a point Q, the length of the tangent to a circle is 40 cm and the distance of Q from the centre is 41 cm. Find the radius of the circle.  
 (a) 4 cm      (b) 3 cm      (c) 6 cm      (d) 9 cm
13. The common point of a tangent to a circle with the circle is called \_\_\_\_\_  
 (a) centre      (b) point of contact      (c) end point      (d) none of these.
14. PQ is a chord of length 8 cm of a circle of radius 5 cm. The tangents at P and Q intersect at a point T (see below figure). Find the length TP.  
 (a)  $\frac{20}{3}$  cm      (b)  $\frac{10}{3}$  cm      (c)  $\frac{40}{3}$  cm      (d) none of these

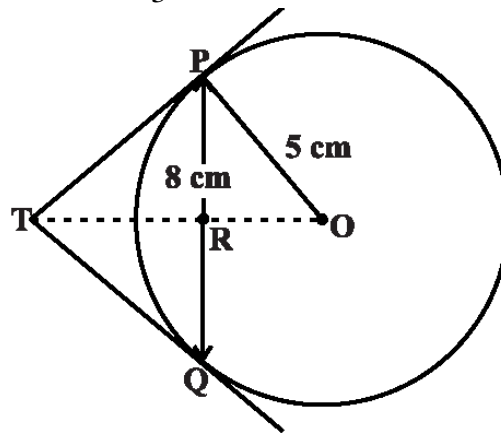

15. The lengths of tangents drawn from an external point to a circle are equal.  
 (a) half      (b) one third      (c) one fourth      (d) equal

**MCQ WORKSHEET-II**  
**CLASS X: CHAPTER – 10**  
**CIRCLES**

1. In below Fig, ABCD is a cyclic quadrilateral in which AC and BD are its diagonals. If  $\angle DBC = 55^\circ$  and  $\angle BAC = 45^\circ$ , find  $\angle BCD$ .  
 (a)  $80^\circ$       (b)  $60^\circ$       (c)  $90^\circ$       (d) none of these

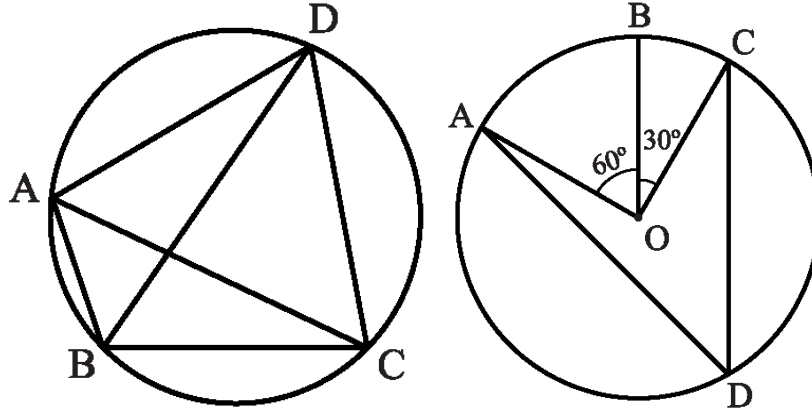

2. In above sided Fig, A, B and C are three points on a circle with centre O such that  $\angle BOC = 30^\circ$  and  $\angle AOB = 60^\circ$ . If D is a point on the circle other than the arc ABC, find  $\angle ADC$ .  
 (a)  $45^\circ$       (b)  $60^\circ$       (c)  $90^\circ$       (d) none of these
3. A chord of a circle is equal to the radius of the circle. Find the angle subtended by the chord at a point on the minor arc  
 (a)  $150^\circ$       (b)  $30^\circ$       (c)  $60^\circ$       (d) none of these
4. A chord of a circle is equal to the radius of the circle. Find the angle subtended by the chord at a point on the major arc.  
 (a)  $150^\circ$       (b)  $30^\circ$       (c)  $60^\circ$       (d) none of these
5. In the below Fig.,  $\angle ABC = 69^\circ$ ,  $\angle ACB = 31^\circ$ , find  $\angle BDC$ .  
 (a)  $80^\circ$       (b)  $60^\circ$       (c)  $90^\circ$       (d)  $100^\circ$

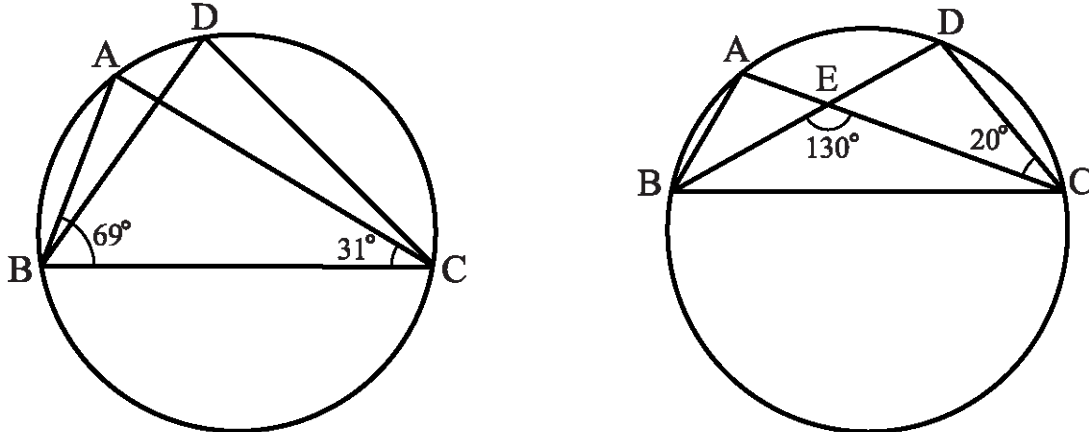

6. In the above sided Fig., A, B, C and D are four points on a circle. AC and BD intersect at a point E such that  $\angle BEC = 130^\circ$  and  $\angle ECD = 20^\circ$ . Find  $\angle BAC$ .  
 (a)  $110^\circ$       (b)  $150^\circ$       (c)  $90^\circ$       (d)  $100^\circ$
7. ABCD is a cyclic quadrilateral whose diagonals intersect at a point E. If  $\angle DBC = 70^\circ$ ,  $\angle BAC$  is  $30^\circ$ , find  $\angle BCD$ .  
 (a)  $80^\circ$       (b)  $60^\circ$       (c)  $90^\circ$       (d)  $100^\circ$

8. ABCD is a cyclic quadrilateral. If  $\angle BCD = 100^\circ$ ,  $\angle ABD$  is  $30^\circ$ , find  $\angle ABC$ .  
 (a)  $80^\circ$       (b)  $60^\circ$       (c)  $90^\circ$       (d)  $70^\circ$
9. ABCD is a cyclic quadrilateral. If  $\angle DBC = 80^\circ$ ,  $\angle BAC$  is  $40^\circ$ , find  $\angle BCD$ .  
 (a)  $80^\circ$       (b)  $60^\circ$       (c)  $90^\circ$       (d)  $70^\circ$
10. ABCD is a cyclic quadrilateral in which BC is parallel to AD,  $\angle ADC = 110^\circ$  and  $\angle BAC = 50^\circ$ .  
 Find  $\angle DAC$   
 (a)  $80^\circ$       (b)  $60^\circ$       (c)  $90^\circ$       (d)  $170^\circ$

11. In the below figure,  $\angle POQ = 80^\circ$ , find  $\angle PAQ$   
 (a)  $80^\circ$       (b)  $40^\circ$       (c)  $100^\circ$       (d) none of these

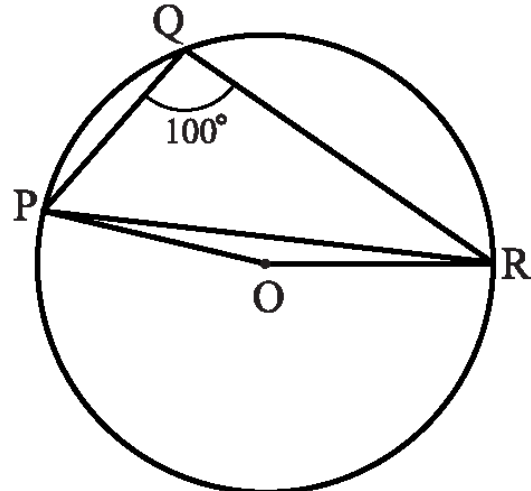
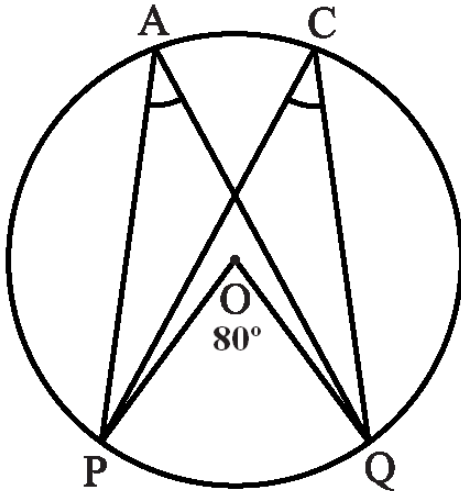

12. In the above figure,  $\angle PQR = 100^\circ$ , where P, Q and R are points on a circle with centre O. Find  $\angle OPR$ .  
 (a)  $80^\circ$       (b)  $40^\circ$       (c)  $10^\circ$       (d) none of these

MCQ WORKSHEET-III  
CLASS X: CHAPTER – 10  
CIRCLES

1. Distance of chord AB from the centre is 12 cm and length of the chord is 10 cm. Then diameter of the circle is  
A. 26 cm                      B. 13 cm                      C.  $\sqrt{244}$  cm                      D. 20 cm
2. Two circles are drawn with side AB and AC of a triangle ABC as diameters. Circles intersect at a point D, Then  
A.  $\angle ADB$  and  $\angle ADC$  are equal                      B.  $\angle ADB$  and  $\angle ADC$  are complementary  
C. Points B, D, C are collinear                      D. none of these
3. The region between a chord and either of the arcs is called  
A. an arc                      B. a sector                      C. a segment                      D. a semicircle
4. A circle divides the plane in which it lies, including circle in  
A. 2 parts                      B. 3 parts                      C. 4 parts                      D. 5 parts
5. If diagonals of a cyclic quadrilateral are the diameters of a circle through the vertices of a quadrilateral, then quadrilateral is a  
A. parallelogram                      B. square                      C. rectangle                      D. trapezium
6. Given three non collinear points, then the number of circles which can be drawn through these three points are  
A. one                      B. zero                      C. two                      D. infinite
7. In a circle with centre O, AB and CD are two diameters perpendicular to each other. The length of chord AC is  
A. 2 AB                      B.  $\sqrt{2}$  AB                      C.  $\frac{1}{2}$  AB                      D.  $\frac{1}{\sqrt{2}}$  AB
8. If AB is a chord of a circle, P and Q are the two points on the circle different from A and B, then  
A.  $\angle APB = \angle AQB$   
B.  $\angle APB + \angle AQB = 180^\circ$   
C.  $\angle APB + \angle AQB = 90^\circ$   
D.  $\angle APB + \angle AQB = 180^\circ$



9. In the above figure,  $\angle PQR = 90^\circ$ , where P, Q and R are points on a circle with centre O. Find reflex  $\angle POR$ .  
 (a)  $180^\circ$       (b)  $140^\circ$       (c)  $45^\circ$       (d) none of these

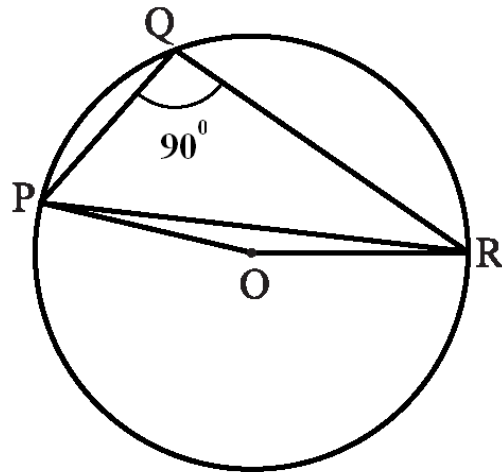

10. In below Fig, ABCD is a cyclic quadrilateral in which AC and BD are its diagonals. If  $\angle DBC = 60^\circ$  and  $\angle BAC = 30^\circ$ , find  $\angle BCD$ .  
 (a)  $80^\circ$       (b)  $60^\circ$       (c)  $90^\circ$       (d) none of these

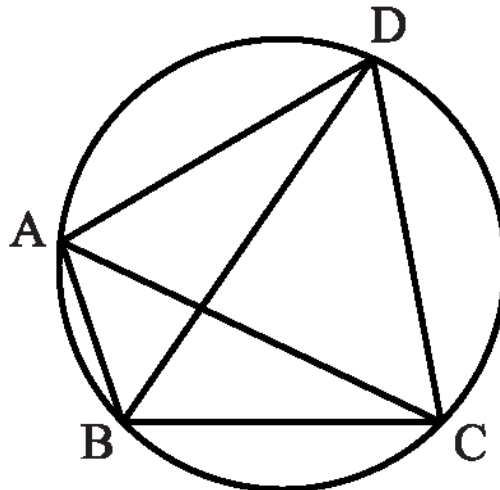

**PRACTICE QUESTIONS**  
**CLASS X: CHAPTER – 10**  
**CIRCLES**

1. Prove that “The tangent at any point of a circle is perpendicular to the radius through the point of contact”.
2. Prove that “The lengths of tangents drawn from an external point to a circle are equal.”
3. Prove that “The centre lies on the bisector of the angle between the two tangents drawn from an external point to a circle.”
4. Find the length of the tangent drawn to a circle of radius 3 cm, from a point distant 5 cm from the centre.
5. A point P is at a distance 13 cm from the centre C of a circle and PT is a tangent to the given circle. If  $PT = 12$  cm, find the radius of the circle.
6. From a point Q, the length of the tangent to a circle is 24 cm and the distance of Q from the centre of the circle is 25 cm. Find the radius of the circle.
7. The tangent to a circle of radius 6 cm from an external point P, is of length 8 cm. Calculate the distance of P from the nearest point of the circle.
8. Prove that in two concentric circles, the chord of the bigger circle, which touches the smaller circle is bisected at the point of contact.
9.  $\Delta PQR$  circumscribes a circle of radius  $r$  such that  $\angle Q = 90^\circ$ ,  $PQ = 3$  cm and  $QR = 4$  cm. Find  $r$ .
10. Prove that the parallelogram circumscribing a circle is a rhombus.

**OR**

If all the sides of a parallelogram touch the circle, show that the parallelogram is a rhombus.

11. ABC is an isosceles triangle in which  $AB = AC$ , circumscribed about a circle. Show that BC is bisected at the point of contact.
12. In Fig., a circle is inscribed in a quadrilateral ABCD in which  $\angle B = 90^\circ$ . If  $AD = 23$  cm,  $AB = 29$  cm and  $DS = 5$  cm, find the radius ( $r$ ) of the circle.

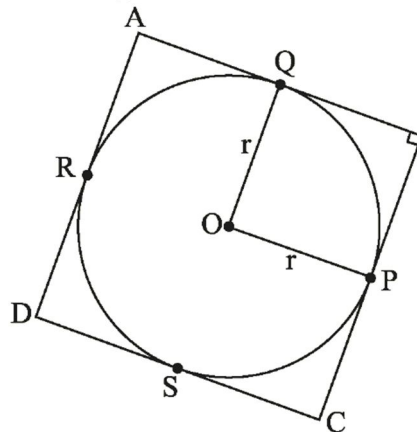

13. ABCD is a quadrilateral such that  $\angle D = 90^\circ$ . A circle  $C(O, r)$  touches the sides AB, BC, CD and DA at P, Q, R and S respectively. If  $BC = 38$  cm,  $CD = 25$  cm and  $BP = 27$  cm, find  $r$ .
14. An isosceles triangle ABC is inscribed in a circle. If  $AB = AC = 13$  cm and  $BC = 10$  cm, find the radius of the circle.
15. Two tangents TP and TQ are drawn from an external point T to a circle with centre O, as shown in fig. If they are inclined to each other at an angle of  $100^\circ$  then what is the value of  $\angle POQ$ ?

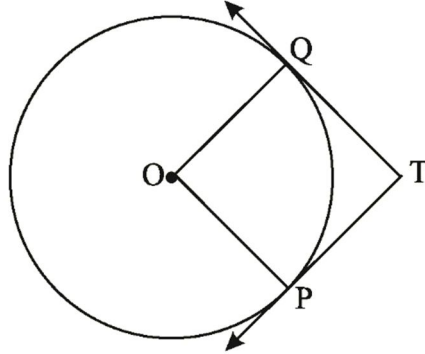

16. The incircle of  $\triangle ABC$  touches the sides BC, CA and AB at D, E and F respectively. If  $AB = AC$ , prove that  $BD = CD$ .
17. XP and XQ are tangents from X to the circle with O, R is a point on the circle and a tangent through R intersects XP and XQ at A and B respectively. Prove that  $XA + AR = XB + BR$ .
18. A circle touches all the four sides of a quadrilateral ABCD with  $AB = 6$  cm,  $BC = 7$  cm and  $CD = 4$  cm. Find AD.

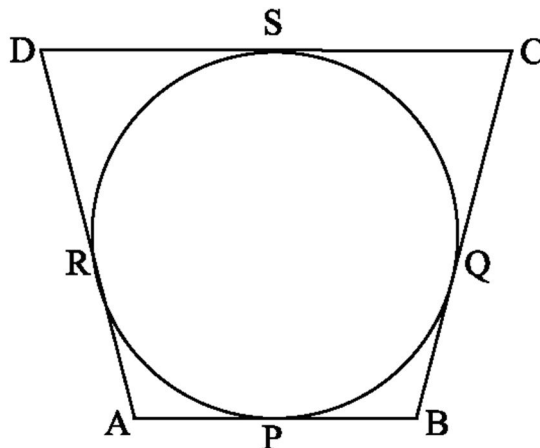

19. TP and TQ are tangents to a circle with centre O at P and Q respectively.  $PQ = 8$  cm and radius of circle is 5 cm. Find TP and TQ.
20. In the below figure PT is tangent to a circle with centre O,  $PT = 36$  cm,  $AP = 24$  cm. Find the radius of the circle.

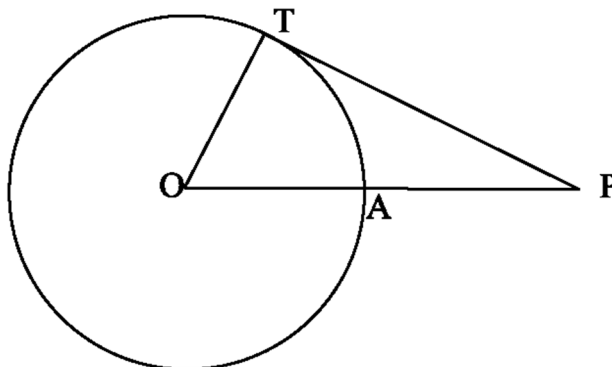

21. In the below figure, find the actual length of sides of  $\triangle OTP$ .

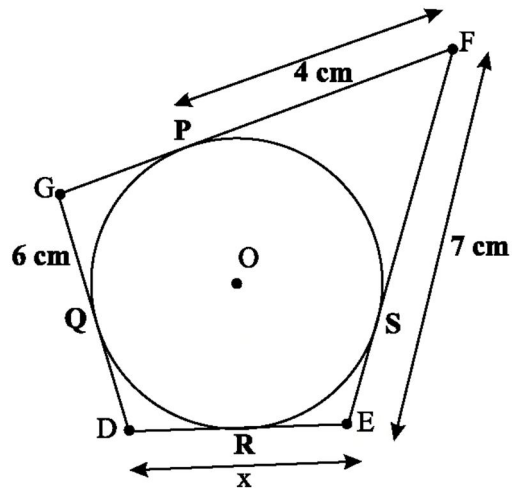
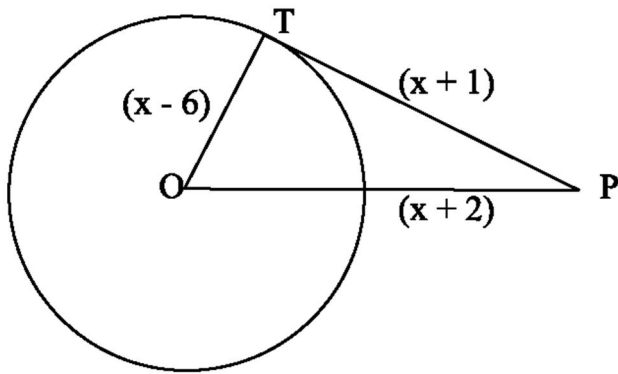

22. In the above sided figure, find the value of  $x$ .

23. Find the perimeter of DEFG.

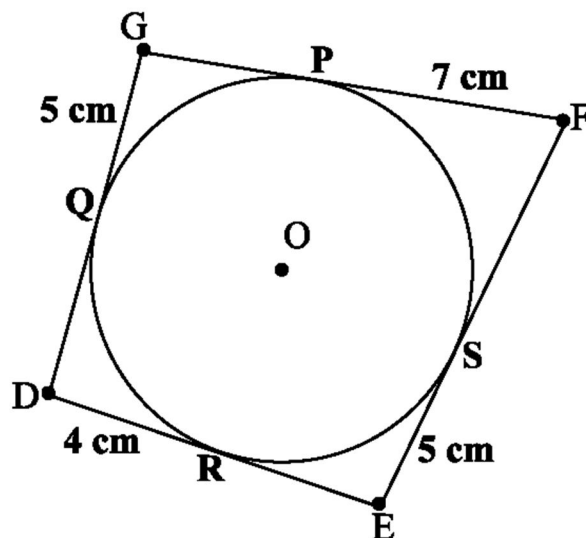

24. Two tangents TP and TQ are drawn to a circle with centre O from an external point T. Prove that  $\angle PTQ = 2\angle OPQ$ .

25. PQ is a chord of length 8 cm of a circle of radius 5 cm. The tangents at P and Q intersect at a point T. Find the length TP.

26. Prove that the perpendicular at the point of contact to the tangent to a circle passes through the centre.

27. The length of a tangent from a point A at distance 5 cm from the centre of the circle is 4 cm. Find the radius of the circle.

28. Two concentric circles are of radii 5 cm and 3 cm. Find the length of the chord of the larger circle which touches the smaller circle.

29. A quadrilateral ABCD is drawn to circumscribe a circle. Prove that  $AB + CD = AD + BC$

30. Prove that the angle between the two tangents drawn from an external point to a circle is supplementary to the angle subtended by the line-segment joining the points of contact at the centre.

31. Prove that opposite sides of a quadrilateral circumscribing a circle subtend supplementary angles at the centre of the circle.

OR

A circle touches all the four sides a quadrilateral ABCD. Prove that the angles subtended at the centre of the circle by the opposite sides are supplementary.

32. PA and PB are the two tangents to a circle with centre O in which OP is equal to the diameter of the circle. Prove that APB is an equilateral triangle.

33. Prove that the intercept of a tangent between two parallel tangents to a circle subtends a right angle at the center of the circle.

34. If PQ and RS are two parallel tangents to a circle with centre O and another tangent X, with point of contact C intersects PQ at A and RS at B. Prove that  $\angle AOB = 90^\circ$ .

35. The incircle of  $\triangle ABC$  touches the sides BC, CA and AB at D, E and F respectively. If  $AB = AC$ , prove that  $BD = DC$ .

36. Two tangents PA and PB are drawn to the circle with center O, such that  $\angle APB = 120^\circ$ . Prove that  $OP = 2AP$ .

37. A circle is touching the side BC of  $\triangle ABC$  at P and is touching AB and AC when produced at Q and R respectively. Prove that  $AQ = \frac{1}{2}$  (Perimeter of  $\triangle ABC$ ).

38. A triangle ABC is drawn to circumscribe a circle of radius 4 cm such that the segments BD and DC into which BC is divided by the point of contact D are of lengths 8 cm and 6 cm respectively. Find the sides AB and AC.

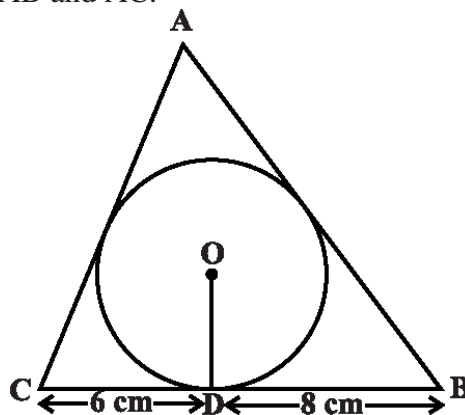

39. In figure, chords AB and CD of the circle intersect at O.  $OA = 5\text{cm}$ ,  $OB = 3\text{cm}$  and  $OC = 2.5\text{cm}$ . Find OD.

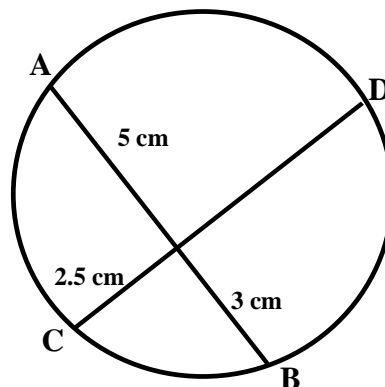

40. In figure. Chords AB and CD intersect at P. If  $AB = 5\text{cm}$ ,  $PB = 3\text{cm}$  and  $PD = 4\text{cm}$ . Find the length of CD.

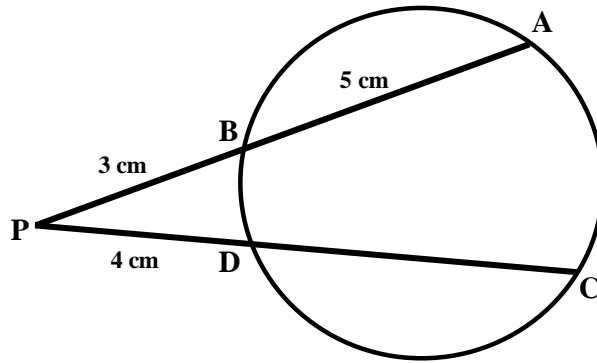

41. In the figure, ABC is an isosceles triangle in which  $AB = AC$ . A circle through B touches the side AC at D and intersect the side AB at P. If D is the midpoint of side AC, Then  $AB = 4AP$ .

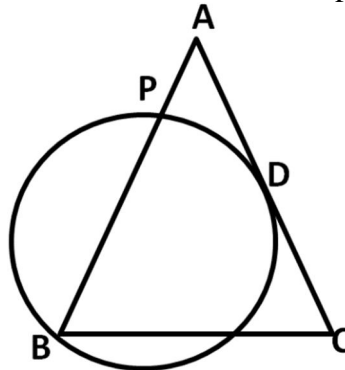

42. In the figure. Find the value of AB Where  $PT = 5\text{cm}$  and  $PA = 4\text{cm}$ .

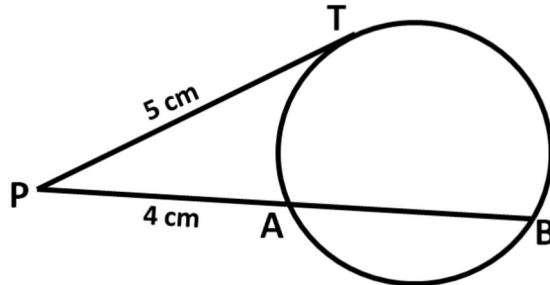

43. In the given figure, a circle touches all the four sides of a quadrilateral ABCD whose sides are  $AB = 6\text{cm}$ ,  $BC = 7\text{cm}$  and  $CD = 4\text{cm}$ . Find AD.

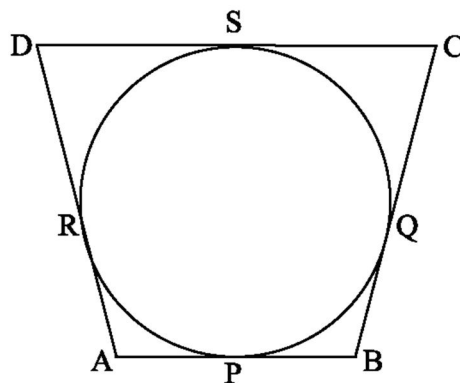

44. Prove that “If a line touches a circle and from the point of contact a chord is drawn, the angle which this chord makes with the given line are equal respectively to the angles formed in the corresponding alternate segments.”
45. Prove that “If a line is drawn through an end point of a chord of a circle so that the angle formed by it with the chord is equal to the angle subtend by chord in the alternate segment, then the line is a tangent to the circle.”



53. In the given figure. PT is a tangent and PAB is a secant to a circle. If the bisector of  $\angle ATB$  intersect AB in M, Prove that: (i)  $\angle PMT = \angle PTM$  (ii)  $PT = PM$

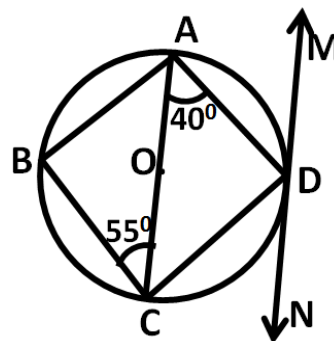
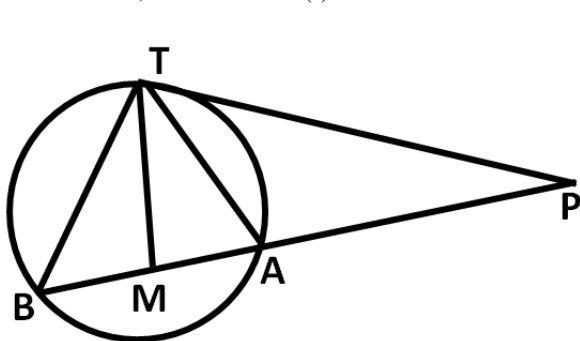

54. In the adjoining figure, ABCD is a cyclic quadrilateral. AC is a diameter of the circle. MN is tangent to the circle at D,  $\angle CAD = 40^\circ$ ,  $\angle ACB = 55^\circ$  Determine  $\angle ADM$  and  $\angle BAD$
55. The diagonals of a parallelogram ABCD intersect at E. Show that the circumcircle of  $\triangle ADE$  and  $\triangle BCE$  touch each other at E.
56. A circle is drawn with diameter AB intersecting the hypotenuse AC of right triangle ABC at the point P. Show that the tangent to the circle at P bisects the side BC.
57. In two concentric circles, prove that all chords of the outer circle which touch the inner circle are of equal length.
58. If AB, AC, PQ are tangents in below figure and  $AB = 5$  cm, find the perimeter of  $\triangle APQ$ .

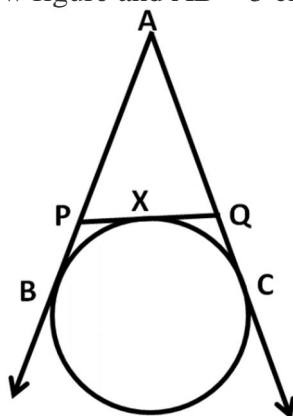

59. If PA and PB are tangents from an outside point P, such that  $PA = 10$  cm and  $\angle APB = 60^\circ$ . Find the length of chord AB.
60. From an external point P, tangents PA and PB are drawn to a circle with centre O. If CD is the tangent to the circle at a point E and  $PA = 14$  cm, find the perimeter of  $\triangle PCD$ .
61. Prove that the tangents at the extremities of any chord make equal angles with the chord.
62. From an external point P, two tangents PA and PB are drawn to the circle with centre O. Prove that OP is the perpendicular bisector of AB.
63. The radius of the incircle of a triangle is 4 cm and the segments into which one side divided by the point of contact are 6 cm and 8 cm. Find the other two sides of the triangle.
64. From a point P, two tangents PA and PB are drawn to a circle with centre O. If  $OP =$  diameter of the circle, show that  $\triangle APB$  is an equilateral triangle.



65. In fig. ABC is a right triangle right angled at B such that  $BC = 6$  cm and  $AB = 8$  cm. Find the radius of its incircle.

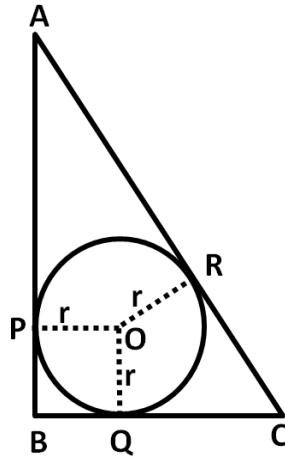

66. In the below figure,  $\triangle ABC$  is circumscribed, find the value of  $x$ .

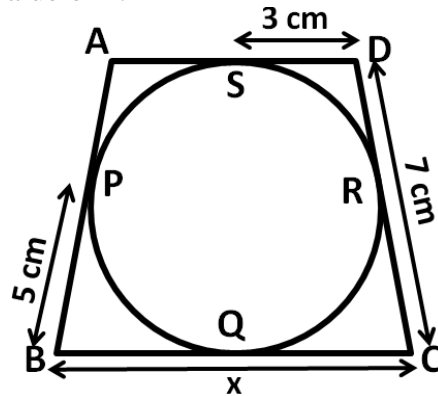
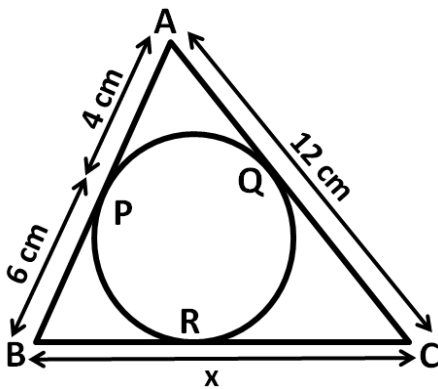

67. In the above right-sided figure, quadrilateral ABCD is circumscribed, find the value of  $x$ .

68. In the below figure, quadrilateral ABCD is circumscribed, find the perimeter of quadrilateral ABCD.

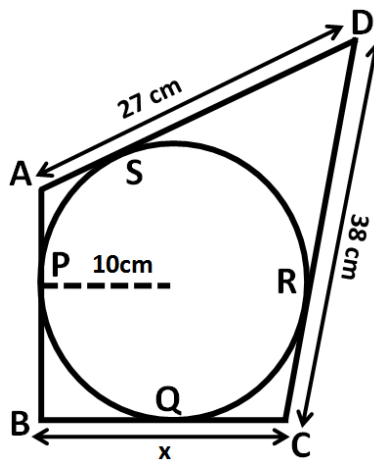
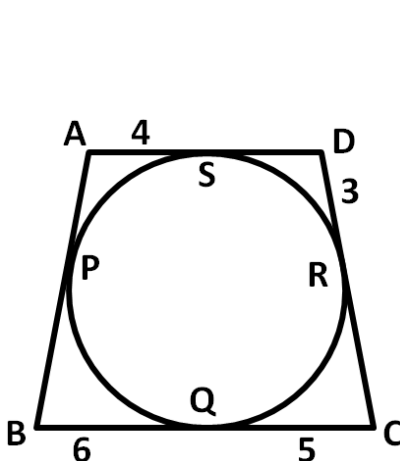

69. In the above right sided figure, quadrilateral ABCD is circumscribed and  $AD \perp DC$ , find the value of  $x$  if the radius of incircle is 10 cm.

70. If an isosceles triangle ABC, in which  $AB = AC = 6$  cm, is inscribed in a circle of radius 9 cm, find the area of the triangle.

71. A is a point at a distance 13 cm from the centre O of a circle of radius 5 cm. AP and AQ are the tangents to the circle at P and Q. If a tangent BC is drawn at a point R lying on the minor arc PQ to intersect AP at B and AQ at C, find the perimeter of the  $\triangle ABC$ .

72. The tangent at a point C of a circle and a diameter AB when extended intersect at P.  
If  $\angle PCA = 110^\circ$ , find  $\angle CBA$

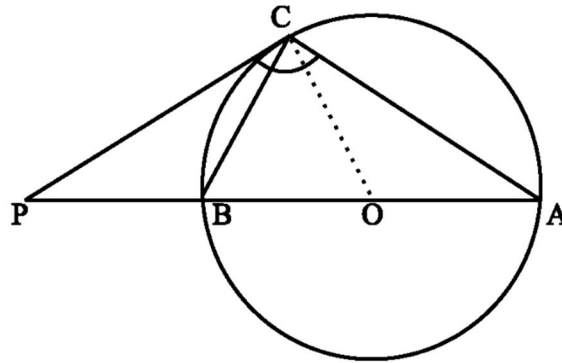

73. In a right triangle ABC in which  $\angle B = 90^\circ$ , a circle is drawn with AB as diameter intersecting the hypotenuse AC at P. Prove that the tangent to the circle at P bisects BC.
74. AB is a diameter and AC is a chord of a circle with centre O such that  $\angle BAC = 30^\circ$ . The tangent at C intersects extended AB at a point D. Prove that  $BC = BD$ .
75. In the below figure from an external point A, tangents AB and AC are drawn to a circle. PQ is a tangent to the circle at X. If  $AC = 15$  cm, find the perimeter of the triangle APQ.

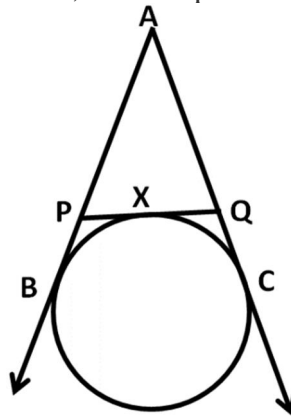

**CLASS X : CHAPTER - 11**  
**CONSTRUCTIONS**

**IMPORTANT CONCEPTS**

To construct a triangle similar to a given triangle as per given scale factor.

**Example 1** - Construct a triangle similar to a given triangle ABC with its sides equal to  $\frac{3}{4}$  of the corresponding sides of the triangle ABC (i.e., of scale factor  $\frac{3}{4}$ ).

**Steps of Construction :**

- ☞ Draw any ray BX making an acute angle with BC on the side opposite to the vertex A.
- ☞ Locate 4 (the greater of 3 and 4 in  $\frac{3}{4}$ ) points B<sub>1</sub>, B<sub>2</sub>, B<sub>3</sub> and B<sub>4</sub> on BX so that BB<sub>1</sub> = B<sub>1</sub>B<sub>2</sub> = B<sub>2</sub>B<sub>3</sub> = B<sub>3</sub>B<sub>4</sub>.
- ☞ Join B<sub>4</sub>C and draw a line through B<sub>3</sub> (the 3rd point, 3 being smaller of 3 and 4 in  $\frac{3}{4}$ ) parallel to B<sub>4</sub>C to intersect BC at C'.
- ☞ Draw a line through C' parallel to the line CA to intersect BA at A' (see below figure).

Then,  $\Delta A'BC'$  is the required triangle.

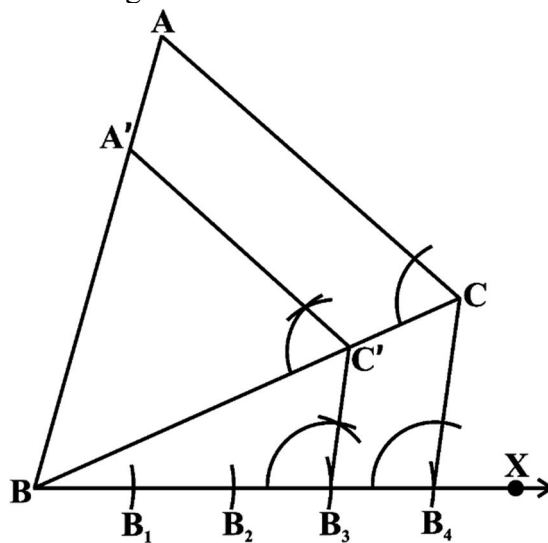

**Example 2** : Construct a triangle similar to a given triangle ABC with its sides equal to  $\frac{5}{3}$  of the corresponding sides of the triangle ABC (i.e., of scale factor  $\frac{5}{3}$ ).

**Steps of Construction :**

- Draw any ray BX making an acute angle with BC on the side opposite to the vertex A.
- Locate 5 points (the greater of 5 and 3 in  $\frac{5}{3}$ ) B<sub>1</sub>, B<sub>2</sub>, B<sub>3</sub>, B<sub>4</sub> and B<sub>5</sub> on BX so that BB<sub>1</sub> = B<sub>1</sub>B<sub>2</sub> = B<sub>2</sub>B<sub>3</sub> = B<sub>3</sub>B<sub>4</sub> = B<sub>4</sub>B<sub>5</sub>.

- Join  $B_3$  (the 3rd point, 3 being smaller of 3 and 5 in  $\frac{5}{3}$ ) to C and draw a line through  $B_5$  parallel to  $B_3C$ , intersecting the extended line segment BC at  $C'$ .
- Draw a line through  $C'$  parallel to CA intersecting the extended line segment BA at  $A'$  (see the below figure).  
Then  $A'BC'$  is the required triangle.

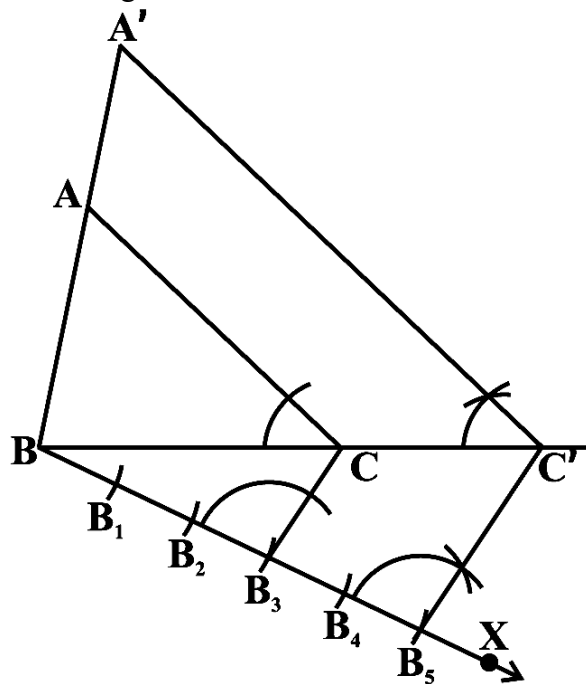

**To construct the tangents to a circle from a point outside it.**

**Given :** We are given a circle with centre 'O' and a point P outside it. We have to construct two tangents from P to the circle.

**Steps of construction :**

- ☞ Join PO and draw a perpendicular bisector of it. Let M be the midpoint of PO.
- ☞ Taking M as centre and PM or MO as radius, draw a circle. Let it intersect the given circle at the points A and B.
- ☞ Join PA and PB.

Then PA and PB are the required two tangents.

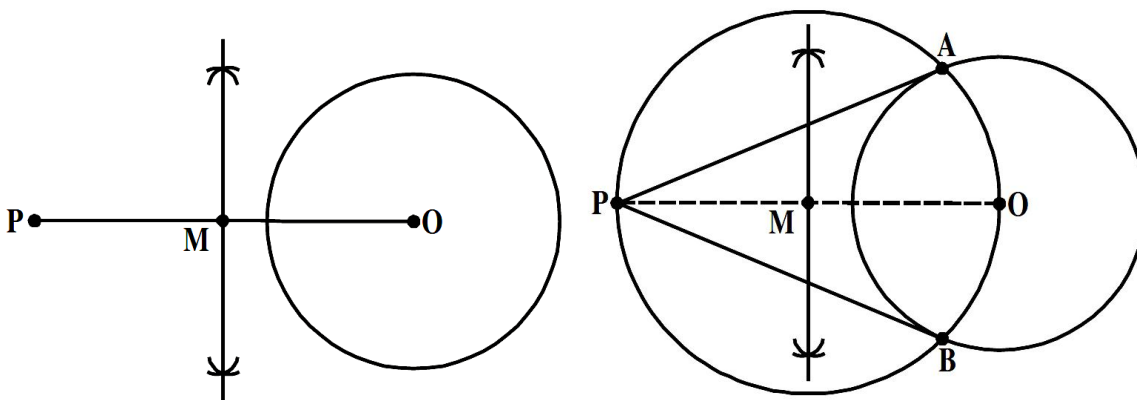

**To Construct a tangent to a circle at a given point when the centre of the circle is known.**

We have a circle with centre 'O' and a point P anywhere on its circumference. Then we have to construct a tangent through P.

**Steps of Construction :**

- ☞ Draw a circle with centre 'O' and mark a point 'P' anywhere on it. Join OP.
- ☞ Draw a perpendicular line through the point P and name it as XY, as shown in the figure.
- ☞ XY is the required tangent to the given circle passing through P.

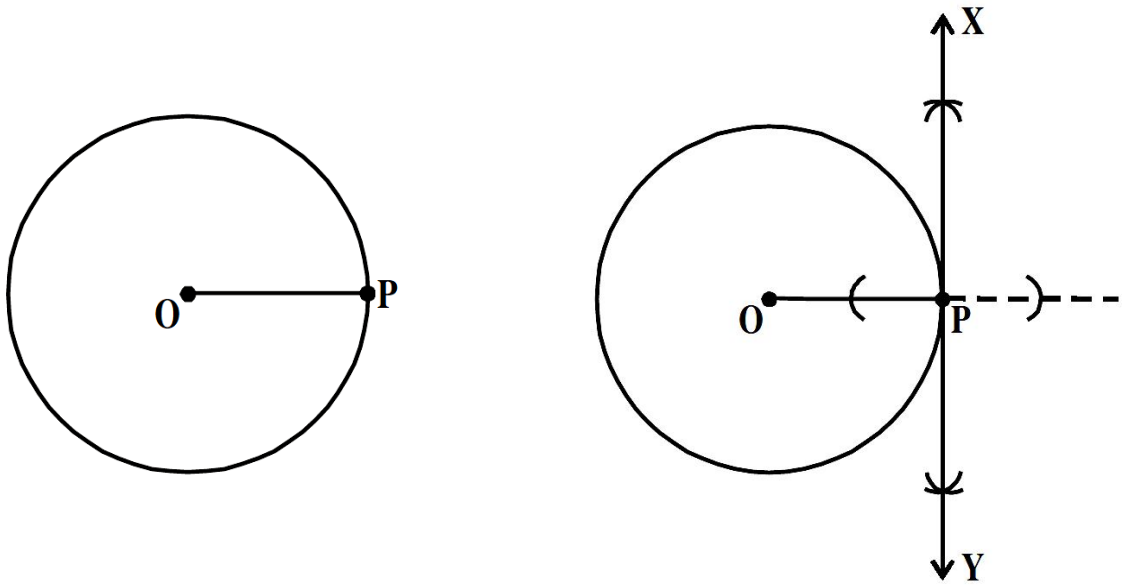

**MCQ WORKSHEET-I**  
**CLASS X: CHAPTER – 11**  
**CONSTRUCTIONS**

1. To divide a line segment AB in the ratio 3 : 7, first a ray AX is drawn so that angle BAX is an acute angle and then at equal distances point are marked on the ray AX such that the minimum number of these point is  
(a) 3                      (b) 10                      (c) 7                      (d) 12
2. To divide a line segment AB in the ratio 4 : 5, first a ray AX is drawn first such that angle BAX is an acute angle and then points A1, A2, A3, .... are located at equal distances on the ray AX and the point B is joined to  
(a) A4                      (b) A5                      (c) A10                      (d) A9
3. To divide a line segment AB in the ratio 4 : 5, first a ray AX is drawn first such that angle BAX is an acute angle, then draw a ray BY parallel to AX and the points A1, A2, A3, .... And B1, B2, B3, ... are located at equal distances on the ray AX and BY respectively, then the points joined are  
(a) A5 and B6                      (b) A6 and B5                      (c) A4 and B5                      (d) A5 and B4
4. To construct a triangle similar to a given  $\Delta ABC$  with its sides  $\frac{2}{5}$  of the corresponding sides of  $\Delta ABC$ , first draw a ray BX such that angle CBX is an acute angle and X lies on the opposite side of A with respect to BC. Then, locate point A1, A2, A3,.... On BX at equal distance and next steps is to join  
(a) A7 to C                      (b) A2 to C                      (c) A5 to C                      (d) A4 to C
5. To construct a triangle similar to a given  $\Delta ABC$  with its sides  $\frac{2}{5}$  of the corresponding sides of  $\Delta ABC$ , first draw a ray BX such that angle CBX is an acute angle and X lies on the opposite side of A with respect to BC. The minimum number of points to be located at equal distances on ray BX is  
(a) 3                      (b) 5                      (c) 8                      (d) 2
6. To construct a triangle similar to a given  $\Delta ABC$  with its sides  $\frac{4}{3}$  of the corresponding sides of  $\Delta ABC$ , first draw a ray BX such that angle CBX is an acute angle and X lies on the opposite side of A with respect to BC. The minimum number of points to be located at equal distances on ray BX is  
(a) 3                      (b) 4                      (c) 7                      (d) none of these
7. To draw a pair of tangents to a circle which are inclined to each other at an angle of  $30^\circ$ , it is required to draw tangents at end points of those two radii of the circle, the angle between them, should be  
(a)  $150^\circ$                       (b)  $90^\circ$                       (c)  $60^\circ$                       (d)  $120^\circ$
8. To draw a pair of tangents to a circle which are inclined to each other at an angle of  $60^\circ$ , it is required to draw tangents at end points of those two radii of the circle, the angle between them, should be  
(a)  $150^\circ$                       (b)  $90^\circ$                       (c)  $60^\circ$                       (d)  $120^\circ$
9. In a pair of set, squares, one if with angles are  
(a)  $30^\circ, 60^\circ, 90^\circ$                       (b)  $30^\circ, 30^\circ, 45^\circ$                       (c)  $75^\circ, 25^\circ, 80^\circ$                       (d)  $65^\circ, 15^\circ, 100^\circ$
10. In a pair of set, squares, the other is with angles  
~~(a)  $45^\circ, 45^\circ, 90^\circ$                       (b)  $30^\circ, 50^\circ, 100^\circ$                       (c)  $60^\circ, 60^\circ, 60^\circ$                       (d) none of these~~

11. To draw the perpendicular bisector of line segment AB, we open the compass  
(a) more than  $\frac{1}{2} AB$  (b) less than  $\frac{1}{2} AB$  (c) equal to  $\frac{1}{2} AB$  (d) none of these
12. To construct an angle of  $22\frac{1}{2}^{\circ}$ , we  
(a) bisect an angle of  $60^{\circ}$  (b) bisect an angle of  $30^{\circ}$   
(c) bisect an angle of  $45^{\circ}$  (d) none of these
13. To construct a triangle we must know at least its \_\_\_\_\_ parts.  
(a) two (b) three (c) one (d) five
14. For which of the following condition the construction of a triangle is not possible:  
(a) If two sides and angle included between them is not given  
(b) If two sides and angle included between them is not given  
(c) If its three sides are given  
(d) If two angles and side included between them is given
15. Construction of a triangle is not possible if:  
(a)  $AB + BC < AC$  (b)  $AB + BC = AC$  (c) both (a) and (b) (d)  $AB + BC > AC$
16. With the help of ruler and compass it is not possible to construct an angle of  
(a)  $37.5^{\circ}$  (b)  $40.5^{\circ}$  (c)  $22.5^{\circ}$  (d)  $67.5^{\circ}$
17. The construction of a triangle ABC given that  $BC = 3$  cm,  $\angle C = 60^{\circ}$  is possible when difference of AB and AC is equal to  
(a) 3.2 cm (b) 3.1 cm (c) 3 cm (d) 2.8 cm
18. The construction of a triangle ABC, given that  $BC = 6$ cm,  $\angle = 45^{\circ}$  is not possible when the difference of AB and AC is equal to  
(a) 6.9 cm (b) 5.2 cm (c) 5.0 cm (d) 4.0 cm.
19. Construction of a triangle is not possible if:  
(a)  $AB - BC < AC$  (b)  $AB - BC = AC$  (c) both (a) and (b) (d)  $AB - BC > AC$
20. To construct an angle of  $15^{\circ}$ , we  
(a) bisect an angle of  $60^{\circ}$  (b) bisect an angle of  $30^{\circ}$   
(c) bisect an angle of  $45^{\circ}$  (d) none of these
- .....

**PRACTICE QUESTIONS**  
**CLASS X: CHAPTER – 11**  
**CONSTRUCTIONS**







1. Draw two tangents to a circle of radius 3.5 cm from a point P at a distance of 5.5 cm from its centre.
2. Construct a similar  $\Delta ABC$  such that each of its side is  $\frac{2}{3}$  of the corresponding sides of  $\Delta ABC$ . It is given that  $AB = 5$  cm,  $AC = 6$ cm and  $BC = 7$ cm.
3. Draw a line segment AB of length 4.4cm. Taking A as centre, draw a circle of radius 2cm and taking B as centre, draw another circle of radius 2.2cm. Construct tangents to each circle from the centre of the other circle.
4. Draw a pair of tangents to a circle of radius 2 cm that are inclined to each other at an angle of  $90^\circ$ .
5. Draw a pair of tangents to a circle of radius 3 cm that are inclined to each other at an angle of  $50^\circ$ .
6. Construct a tangent to a circle of radius 2 cm from a point on the concentric circle of radius 2.6cm and measure its length. Also, verify the measurements by actual calculations.
7. Construct an isosceles triangle whose base is 7 cm and altitude 4 cm and then construct another similar triangle whose sides are  $\frac{3}{2}$  time the corresponding sides of the isosceles triangle.
8. Construct an isosceles triangle whose base is 8 cm and altitude 4 cm and then another triangle whose sides are  $1\frac{1}{2}$  times the corresponding sides of the isosceles triangle.
9. Draw a triangle ABC with side  $BC = 6$  cm,  $AB = 5$  cm and  $\angle ABC = 60^\circ$ . Then construct a triangle whose sides are  $\frac{3}{4}$  of the corresponding sides of the triangle ABC.
10. Draw a triangle ABC with side  $BC = 7$  cm,  $\angle B = 45^\circ$ ,  $\angle A = 105^\circ$ . Then, construct a triangle whose sides are  $\frac{4}{3}$  times the corresponding sides of  $\Delta ABC$ .
11. Draw a right triangle in which the sides (other than hypotenuse) are of lengths 4 cm and 3 cm. Then construct another triangle whose sides are  $\frac{5}{3}$  times the corresponding sides of the given triangle.
12. Draw a circle with the help of a bangle. Take a point outside the circle. Construct the pair of tangents from this point to the circle.
13. Draw a circle of radius 6 cm. From a point 10 cm away from its centre, construct the pair of tangents to the circle and measure their lengths.

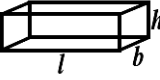
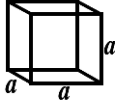

14. Construct a tangent to a circle of radius 4 cm from a point on the concentric circle of radius 6 cm and measure its length. Also verify the measurement by actual calculation.
15. Draw a circle of radius 3 cm. Take two points P and Q on one of its extended diameter each at a distance of 7 cm from its centre. Draw tangents to the circle from these two points P and Q.
16. Draw a pair of tangents to a circle of radius 5 cm which are inclined to each other at an angle of  $60^\circ$ .
17. Draw a line segment AB of length 8 cm. Taking A as centre, draw a circle of radius 4 cm and taking B as centre, draw another circle of radius 3 cm. Construct tangents to each circle from the centre of the other circle.
18. Draw a circle of radius 5cm. Take a point P on it. Without using the centre of the circle, construct a tangent at the point P. Write the steps of construction also.
19. Draw a circle of diameter 12cm. From a point P, 10cm away from its centre, construct a pair of tangent to the circle. Measure the lengths of the tangent segments.
20. Draw a circle of radius 5cm. from a point P, 7cm away from its centre, construct a pair of tangents to the circle. Measure the length of the tangent segments.
21. Draw a circle of radius 7cm. From a point P, 8cm away from its centre, Construct a pair tangents to the circle. Measure the length of the tangent segments.
22. Draw a right angled triangle ABC with  $AB = 4.5\text{cm}$ ,  $AC = 7.5\text{cm}$  and  $\angle B = 90^\circ$ . Construct its incircle. Write the steps of construction.
23. Construct a triangle ABC in which  $BC = 13\text{cm}$ ,  $CA = 5\text{cm}$  and  $AB = 12\text{cm}$ . Draw its incircle and measure its radius.
24. Construct a triangle ABC in which  $AB = 3\text{cm}$ ,  $BC = 4\text{cm}$  and  $AC = 5\text{cm}$ . Draw the circumcircle of triangle ABC.
25. Construct the circumcircle of an equilateral triangle with side 6cm. Write the steps of construction.

**CLASS X : CHAPTER - 13**  
**SURFACE AREAS AND VOLUMES**

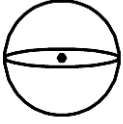
**IMPORTANT FORMULAS & CONCEPTS**

S. No.	Name of the solid	Figure	Lateral / Curved surface area	Total surface area	Volume	Nomenclature
1.	Cuboid		$2h(l+b)$	$2(lb+bh+hl)$	$lbh$	$l$ :length $b$ :breadth $h$ :height
2.	Cube		$4a^2$	$6a^2$	$a^3$	$a$ :side of the cube
3.	Right prism		Perimeter of base $\times$ height	Lateral surface area+2(area of the end surface)	area of base $\times$ height	-
4.	Regular circular Cylinder		$2\pi rh$	$2\pi r(r+h)$	$\pi r^2 h$	$r$ :radius of the base $h$ :height
5.	Right pyramid		$\frac{1}{2}$ (perimeter of base) $\times$ slant height	Lateral surfaces area+area of the base	$\frac{1}{3}$ area of the base $\times$ height	-
6.	Right circular cone		$\pi rl$	$\pi r(l+r)$	$\frac{1}{3} \pi r^2 h$	$r$ :radius of the base $h$ :height $l$ :slant height
7.	Sphere		$4\pi r^2$	$4\pi r^2$	$\frac{4}{3} \pi r^3$	$r$ :radius
8.	Hemisphere		$2\pi r^2$	$3\pi r^2$	$\frac{2}{3} \pi r^3$	$r$ :radius

**Frustum of a Cone** - If a right circular cone is cut off by a plane parallel to its base, then the portion of the cone between the cutting plane and the base of the cone is called a frustum of a cone.

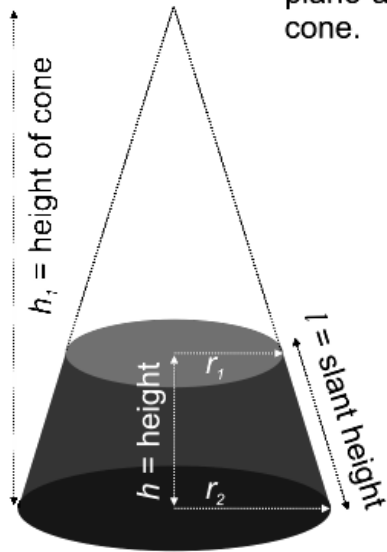

<b>Slant Height of Frustum ( <math>l</math> )</b>	$\sqrt{h^2 + (r_1 - r_2)^2}$
<b>Lateral Surface Area</b>	$\pi (r_1 + r_2) l$
<b>Total Surface Area</b>	$\pi \{ (r_1 + r_2) l + r_1^2 + r_2^2 \}$
<b>Volume</b>	$\frac{\pi}{3} (r_1^2 + r_1 r_2 + r_2^2) h$
<b>Height of cone of which the frustum is part of ( <math>h_1</math> )</b>	$\frac{h r_1}{(r_1 - r_2)}$



**MCQ WORKSHEET-I**  
**CLASS X: CHAPTER – 13**  
**SURFACE AREAS AND VOLUMES**

1. The surface area of a cuboid is  
(a)  $2(lb + bh + lh)$     (b)  $3(lb + bh + lh)$     (c)  $2(lb - bh - lh)$     (d)  $3(lb - bh - lh)$
2. The surface area of a cube if edge 'a' is  
(a)  $7a^2$     (b)  $6a^2$     (c)  $5a^3$     (d)  $5a^2$
3. The length, breadth and height of a room is 5m, 4m and 3m. The cost of white washing its four walls at the rate of Rs. 7.50 per  $m^2$  is  
(a) Rs. 110    (b) Rs. 109    (c) Rs. 220    (d) Rs. 105
4. The perimeter of floor of rectangular hall is 250m. The cost of the white washing its four walls is Rs. 15000. The height of the room is  
(a) 5m    (b) 4m    (c) 6m    (d) 8m
5. The breadth of a room is twice its height and is half of its length. The volume of room is  $512dm^3$ . Its dimensions are  
(a) 16 dm, 8 dm, 4 dm    (b) 12 dm, 8 dm, 2 dm  
(c) 8 dm, 4 dm, 2 dm    (d) 10 dm, 15 dm, 20 dm
6. The area of three adjacent faces of a cube is x, y and z. Its volume V is  
(a)  $V = xyz$     (b)  $V^3 = xyz$     (c)  $V^2 = xyz$     (d) none of these
7. Two cubes each of edge 12 cm are joined. The surface area of new cuboid is  
(a)  $140 cm^2$     (b)  $1440 cm^2$     (c)  $144 cm^2$     (d)  $72 cm^2$
8. The curved surface area of cylinder of height 'h' and base radius 'r' is  
(a)  $2\pi rh$     (b)  $\pi rh$     (c)  $\frac{1}{2}\pi rh$     (d) none of these
9. The total surface area of cylinder of base radius 'r' and height 'h' is  
(a)  $2\pi(r + h)$     (b)  $2\pi r(r + h)$     (c)  $3\pi r(r + h)$     (d)  $4\pi r(r + h)$
10. The curved surface area of a cylinder of height 14 cm is  $88 cm^2$ . The diameter of its circular base is  
(a) 5cm    (b) 4cm    (c) 3cm    (d) 2cm
11. It is required to make a closed cylindrical tank of height 1 m and base diameter 140cm from a metal sheet. How many square meters a sheet are required for the same?  
(a)  $6.45m^2$     (b)  $6.48m^2$     (c)  $7.48m^2$     (d)  $5.48m^2$ .
12. A metal pipe is 77 cm long. Inner diameter of cross section is 4 cm and outer diameter is 4.4 cm. Its inner curved surface area is:  
(a)  $864 cm^2$     (b)  $968 cm^2$     (c)  $768 cm^2$     (d) none of these

**MCQ WORKSHEET-II**  
**CLASS X: CHAPTER – 13**  
**SURFACE AREAS AND VOLUMES**

1. The diameter of a roller is 84 cm and its length is 120 cm. It takes 500 complete revolutions to move once over to level a playground. The area of the playground in  $m^2$  is:  
(a) 1584      (b) 1284      (c) 1384      (d) 1184
2. A cylindrical pillar is 50 cm in diameter and 3.5 m in height. The cost of painting its curved surface at the rate of Rs. 12.50 per  $m^2$  is:  
(a) Rs. 68.75   (b) Rs. 58.75   (c) Rs. 48.75   (d) Rs. 38.75
3. The inner diameter of circular well is 3.5m. It is 10m deep. Its inner curved surface area in  $m^2$  is:  
(a) 120      (b) 110      (c) 130      (d) 140
4. In a hot water heating system there is a cylindrical pipe of length 28 m and diameter 5 cm. The total radiating surface area in the system in  $m^2$  is:  
(a) 6.6      (b) 5.5      (c) 4.4      (d) 3.4
5. The curved surface area of a right circular cone of slant height 10 cm and base radius 7 cm is  
(a)  $120\text{ cm}^2$    (b)  $220\text{ cm}^2$    (c)  $240\text{ cm}^2$       (d)  $140\text{ cm}^2$
6. The height of a cone is 16 cm and base radius is 12 cm. Its slant height is  
(a) 10 cm      (b) 15 cm      (c) 20 cm      (d) 8 cm
7. The curved surface area of a right circular cone of height 16 cm and base radius 12 cm is  
(a)  $753.6\text{ cm}^2$    (b)  $1205.76\text{ cm}^2$       (c)  $863.8\text{ cm}^2$       (d)  $907.6\text{ cm}^2$
8. The curved surface area of a right circular cone of slant height 10 cm and base radius 10.5 cm is  
(a)  $185\text{ cm}^2$    (b)  $160\text{ cm}^2$    (c)  $165\text{ cm}^2$       (d)  $195\text{ cm}^2$
9. The slant height of a cone is 26 cm and base diameter is 20 cm. Its height is  
(a) 24 cm      (b) 25 cm      (c) 23 cm      (d) 35 cm
10. The curved surface area of a cone is  $308\text{ cm}^2$  and its slant height is 14 cm. The radius of its base is  
(a) 8 cm      (b) 7 cm      (c) 9 cm      (d) 12 cm
11. A conical tent is 10 m high and the radius of its base is 24 m. The slant height of tent is  
(a) 26 m      (b) 28 m      (c) 25 m      (d) 27 m
12. The slant height and base diameter of a conical tomb are 25 m and 14 m respectively. The cost of white washing its curved surface at the rate of Rs. 210 per  $100\text{ m}^2$  is  
(a) Rs. 1233   (b) Rs. 1155   (c) Rs. 1388   (d) Rs. 1432

**MCQ WORKSHEET-III**  
**CLASS X: CHAPTER – 13**  
**SURFACE AREAS AND VOLUMES**

1. A joker's cap is in the form of cone of base radius 7 cm and height 24 cm. The area of sheet to make 10 such caps is  
(a)  $5500 \text{ cm}^2$  (b)  $6500 \text{ cm}^2$  (c)  $8500 \text{ cm}^2$  (d)  $3500 \text{ cm}^2$
2. A solid right cylinder cone is cut into two parts at the middle of its height by a plane parallel to its base. The ratio of the volume of the smaller cone to the whole cone is  
(a) 1 : 2 (b) 1 : 4 (c) 1 : 6 (d) 1 : 8
3. The total surface area of a hemisphere of radius 'r' is  
(a)  $2\pi r^2$  (b)  $4\pi r^2$  (c)  $3\pi r^2$  (d)  $5\pi r^2$
4. The curved surface area of a sphere of radius 7 cm is:  
(a)  $516 \text{ cm}^2$  (b)  $616 \text{ cm}^2$  (c)  $716 \text{ cm}^2$  (d)  $880 \text{ cm}^2$
5. The curved surface area of a hemisphere of radius 21 cm is:  
(a)  $2772 \text{ cm}^2$  (b)  $2564 \text{ cm}^2$  (c)  $3772 \text{ cm}^2$  (d)  $4772 \text{ cm}^2$
6. The curved surface area of a sphere of radius 14 cm is:  
(a)  $2464 \text{ cm}^2$  (b)  $2428 \text{ cm}^2$  (c)  $2464 \text{ cm}^2$  (d) none of these.
7. The curved surface area of a sphere of diameter 14 cm is:  
(a)  $516 \text{ cm}^2$  (b)  $616 \text{ cm}^2$  (c)  $716 \text{ cm}^2$  (d)  $880 \text{ cm}^2$
8. Total surface area of hemisphere of radius 10 cm is  
(a)  $942 \text{ cm}^2$  (b)  $940 \text{ cm}^2$  (c)  $842 \text{ cm}^2$  (d)  $840 \text{ cm}^2$
9. The radius of a spherical balloon increases from 7 cm to 14 cm s air is being pumped into it. The ratio of surface area of the balloon in the two cases is:  
(a) 4 : 1 (b) 1 : 4 (c) 3 : 1 (d) 1 : 3
10. A matchbox measures 4 cm x 2.5 cm x 1.5 cm. The volume of packet containing 12 such boxes is:  
(a)  $160 \text{ cm}^3$  (b)  $180 \text{ cm}^3$  (c)  $160 \text{ cm}^2$  (d)  $180 \text{ cm}^2$
11. A cuboidal water tank is 6 m long, 5 m wide and 4.5 m deep. How many litre of water can it hold?  
(a) 1350 liters (b) 13500 liters (c) 135000 liters (d) 135 liters
12. A cuboidal vessel is 10 m long and 8 m wide. How high must it be made to hold 380 cubic metres of a liquid?  
(a) 4.75 m (b) 7.85 m (c) 4.75 cm (d) none of these
13. The capacity of a cuboidal tank is 50000 litres. The length and depth are respectively 2.5 m and 10 m. Its breadth is  
(a) 4 m (b) 3 m (c) 2 m (d) 5 m
14. A godown measures 40 m  $\times$  25 m  $\times$  10 m. Find the maximum number of wooden crates each measuring 1.5 m  $\times$  1.25 m  $\times$  0.5 m that can be stored in the godown.  
(a) 18000 (b) 16000 (c) 15000 (d) 14000

**MCQ WORKSHEET-IV**  
**CLASS X: CHAPTER – 13**  
**SURFACE AREAS AND VOLUMES**

1. A river 3 m deep and 40 m wide is flowing at the rate of 2 km per hour. How much water will fall into the sea in a minute?  
(a)  $4000 \text{ m}^3$    (b)  $40 \text{ m}^3$    (c)  $400 \text{ m}^3$    (d)  $40000 \text{ m}^3$
2. The circumference of the base of a cylindrical vessel is 132 cm and its height is 25 cm. How many litres of water can it hold?  
(a) 33.75 litre   (b) 34.65 litre   (c) 35.75 litre   (d) 38.75 litre
3. If the lateral surface of a cylinder is  $94.2 \text{ cm}^2$  and its height is 5 cm, then find radius of its base  
(a) 5cm   (b) 4cm   (c) 3cm   (d) 6cm
4. It costs Rs 2200 to paint the inner curved surface of a cylindrical vessel 10 m deep. If the cost of painting is at the rate of Rs 20 per  $\text{m}^2$ , find radius of the base,  
(a) 1.75 m   (b) 1.85 m   (c) 1.95 m   (d) 1.65 m
5. The height and the slant height of a cone are 21 cm and 28 cm respectively. Find the volume of the cone.  
(a)  $5546 \text{ cm}^3$    (b)  $7546 \text{ cm}^3$    (c)  $5564 \text{ m}^3$    (d)  $8546 \text{ cm}^3$
6. Find the volume of the right circular cone with radius 6 cm, height 7 cm  
(a)  $254 \text{ cm}^3$    (b)  $264 \text{ cm}^3$    (c)  $274 \text{ cm}^2$    (d)  $284 \text{ cm}^3$
7. The radius and height of a conical vessel are 7 cm and 25 cm respectively. Its capacity in litres is  
(a) 1.232 litre   (b) 1.5 litre   (c) 1.35 litre   (d) 1.6 litre
8. The height of a cone is 15 cm. If its volume is  $1570 \text{ cm}^3$ , find the radius of the base.  
(a) 12 cm   (b) 10 cm   (c) 15 cm   (d) 18 cm
9. If the volume of a right circular cone of height 9 cm is  $48\pi \text{ cm}^3$ , find the diameter of its base.  
(a) 12 cm   (b) 10 cm   (c) 6 cm   (d) 8 cm
10. A conical pit of top diameter 3.5 m is 12 m deep. What is its capacity in kilolitres?  
(a) 38.5 kl   (b) 48.5 kl   (c) 39.5 kl   (d) 47.5 kl
11. Find the capacity in litres of a conical vessel with radius 7 cm, slant height 25 cm  
(a) 1.232 litre   (b) 1.5 litre   (c) 1.35 litre   (d) none of these
12. The diameter of the moon is approximately one-fourth of the diameter of the earth. What fraction of the volume of the earth is the volume of the moon?  
(a)  $\frac{1}{64}$    (b)  $\frac{1}{32}$    (c)  $\frac{1}{16}$    (d)  $\frac{1}{48}$
13. The dimensions of a cuboid are 50 cm x 40 cm x 10 cm. Its volume in litres is:  
(a) 10 litres   (b) 12 litres   (c) 20 litres   (d) 25 litres
14. The volume of a cuboidal tank is  $250 \text{ m}^3$ . If its base area is  $50 \text{ m}^2$  then depth of the tank is  
(a) 5 m   (b) 200 m   (c) 300 m   (d) 12500 m

**MCQ WORKSHEET-V**  
**CLASS X: CHAPTER – 13**  
**SURFACE AREAS AND VOLUMES**

1. The length, breadth and height of a cuboidal solid is 4 cm, 3 cm and 2 cm respectively. Its volume is  
(a)  $(4 + 3 + 2) \text{ cm}^3$     (b)  $2(4 + 3 + 2) \text{ cm}^3$     (c)  $(4 \times 3 \times 2) \text{ cm}^3$     (d)  $2(4 + 3) \times 2 \text{ cm}^3$
2. The volume of a cuboidal solid of length 8 m and breadth 5 m is  $200 \text{ m}^3$ . Find its height.  
(a) 5 m    (b) 6 m    (c) 15 m    (d) 18 m
3. The curved surface area of a sphere is  $616 \text{ cm}^2$ . Its radius is  
(a) 7 cm    (b) 5 cm    (c) 6 cm    (d) 8 cm
4. If radius of a sphere is  $\frac{2d}{3}$  then its volume is  
(a)  $\frac{32}{81} \pi d^3$     (b)  $\frac{23}{4} \pi d^3$     (c)  $\frac{32}{3} \pi d^3$     (d)  $\frac{34}{3} \pi d^3$
5. The capacity of a cylindrical tank is  $6160 \text{ cm}^3$ . Its base diameter is 28 m. The depth of this tank is  
(a) 5 m    (b) 10 m    (c) 15 m    (d) 8 m
6. The volume of a cylinder of radius r and length h is:  
(a)  $2\pi rh$     (b)  $\frac{4}{3} \pi r^2 h$     (c)  $\pi r^2 h$     (d)  $2\pi r^2 h$
7. Base radius of two cylinder are in the ratio 2 : 3 and their heights are in the ratio 5 : 3. The ratio of their volumes is  
(a) 27 : 20    (b) 25 : 24    (c) 20 : 27    (d) 15 : 20
8. If base radius and height of a cylinder are increased by 100% then its volume increased by:  
(a) 30%    (b) 40%    (c) 42%    (d) 33.1%
9. The diameter of a sphere is 14 m. The volume of this sphere is  
(a)  $1437\frac{1}{3} \text{ m}^3$     (b)  $1357\frac{1}{3} \text{ m}^3$     (c)  $1437\frac{2}{3} \text{ m}^3$     (d)  $1337\frac{2}{3} \text{ m}^3$
10. The volume of a sphere is  $524 \text{ cm}^3$ . The diameter of sphere is  
(a) 5cm    (b) 4cm    (c) 3cm    (d) 7cm
11. The total surface area of a cylinder is  $40\pi \text{ cm}^2$ . If height is 5.5 cm then its base radius is  
(a) 5cm    (b) 2.5cm    (c) 1.5cm    (d) 10cm
12. The area of circular base of a right circular cone is  $78.5 \text{ cm}^2$ . If its height is 12 cm then its volume is  
(a)  $31.4 \text{ cm}^3$     (b)  $3.14 \text{ cm}^3$     (c)  $314 \text{ cm}^3$     (d) none of these
13. The base radius of a cone is 11.3 cm and curved surface area is  $355 \text{ cm}^2$ . Its height is (Take  $\pi = \frac{355}{113}$ )  
(a) 5 cm    (b) 10 cm    (c) 11 cm    (d) 9 cm



**MCQ WORKSHEET-VI**  
**CLASS X: CHAPTER – 13**  
**SURFACE AREAS AND VOLUMES**

1. If the dimensions of a cuboid are 3 cm, 4 cm and 10 cm, then its surface area is  
A.  $82 \text{ cm}^2$       B.  $123 \text{ cm}^2$       C.  $164 \text{ cm}^2$       D.  $216 \text{ cm}^2$
2. The volume of the cuboid in Q.1 is  
A.  $17 \text{ cm}^3$       B.  $164 \text{ cm}^3$       C.  $120 \text{ cm}^3$       D.  $240 \text{ cm}^3$
3. The surface area of a cuboid is 1372 sq. cm. If its dimensions are in the ratio of 4 : 2 : 1, then its length is  
A. 7 cm      B. 14 cm      C. 21 cm      D. 28cm
4. The base radius and height of a right circular cylinder are 7 cm and 13.5 cm. The volume of cylinder is  
A.  $1579 \text{ cm}^3$       B.  $1897 \text{ cm}^3$       C.  $2079 \text{ cm}^3$       D.  $2197 \text{ cm}^3$
5. The base radius of a cone is 5 cm and its height is 12 cm. Its slant height is  
A. 13 cm      B. 19.5 cm      C. 26 cm      D. 52cm
6. The curved surface area of a cylinder of height 14 cm is 88 sq. cm. The diameter of the cylinder is  
A. 0.5 cm      B. 1.0 cm      C. 1.5 cm      D. 2.0 cm
7. The lateral surface area of a right circular cone of height 28 cm and base radius 21 cm is  
A.  $1155 \text{ cm}^2$       B.  $1055 \text{ cm}^2$       C.  $2110 \text{ cm}^2$       D.  $2310 \text{ cm}^2$
8. The circumference of the base of a 8 m high conical tent is  $\frac{264}{7} \text{ m}^2$ . The area of canvas required to make the tent is  
A.  $\frac{1360}{7} \text{ cm}^2$       B.  $\frac{1360}{14} \text{ cm}^2$       C.  $286 \text{ cm}^2$       D.  $98 \text{ cm}^2$
9. The area of metal sheet required to make a closed hollow cone of height 24 m and base radius 7 m is  
A.  $176 \text{ m}^2$       B.  $352 \text{ m}^2$       C.  $704 \text{ m}^2$       D.  $1408 \text{ m}^2$
10. The diameter of a sphere whose surface area is  $346.5 \text{ cm}^2$  is  
A. 5.25 cm      B. 5.75 cm      C. 11.5 cm      D. 10.5 cm
11. The radius of a spherical balloon increases from 7 cm to 14 cm when air is pumped into it. The ratio of the surface area of original balloon to inflated one is  
A. 1 : 2      B. 1 : 3      C. 1 : 4      D. 4 : 3

12. The circumference of the base of a cylindrical vessel is 132 cm and its height is 25 cm. If 1000 cu.cm = 1 liter, the number of litres, of water the vessel can hold is
- A. 17.325                  B. 34.65                  C. 34.5                  D. 69.30
13. The number of litres of milk a hemispherical bowl of radius 10.5 cm can hold is
- A. 2.47                  B. 2.476                  C. 2.376                  D. 3.476
14. The number of bricks, each measuring 18 cm × 12 cm × 10 cm are required to build a wall 12 m × 0.6 m × 4.5 m if  $\frac{1}{10}$  of its volume is taken by mortar, is
- A. 15000                  B. 13500                  C. 12500                  D. 13900
15. The radius of a sphere is 10 cm. If its radius is increased by 1 cm, the volume of the sphere is increased by
- A. 13.3%                  B. 21.1%                  C. 30%                  D. 33.1%
- .....

**MCQ WORKSHEET-VII**  
**CLASS X: CHAPTER – 13**  
**SURFACE AREAS AND VOLUMES**

1. The total surface area of a solid hemisphere of radius  $r$  is  
(A)  $\pi r^2$                       (B)  $2\pi r^2$                       (C)  $3\pi r^2$                       (D)  $4\pi r^2$
  2. The volume and the surface area of a sphere are numerically equal, then the radius of sphere is  
(A) 0 units                      (B) 1 units                      (C) 2 units                      (D) 3 units
  3. A cylinder, a cone and a hemisphere are of the same base and of the same height. The ratio of their volumes is  
(A) 1 : 2 : 3                      (B) 2 : 1 : 3                      (C) 3 : 1 : 2                      (D) 3 : 2 : 1
  4. Small spheres, each of radius 2cm, are made by melting a solid iron ball of radius 6cm, then the total number of small spheres is  
(A) 9                      (B) 6                      (C) 27                      (D) 81
  5. A solid sphere of radius  $r$  cm is melted and recast into the shape of a solid cone of height  $r$ . Then the radius of the base of cone is  
(A)  $2r$                       (B)  $r$                       (C)  $4r$                       (D)  $3r$
  6. Three solid spheres of diameters 6cm, 8cm and 10cm are melted to form a single solid sphere. The diameter of the new sphere is  
(A) 6 cm                      (B) 4.5 cm                      (C) 3 cm                      (D) 12 cm
  7. The radii of the ends of a frustum of a cone 40 cm high are 38 cm and 8 cm. The slant height of the frustum of cone is  
(A) 50 cm                      (B)  $10\sqrt{7}$  cm                      (C) 60.96 cm                      (D)  $4\sqrt{2}$  cm
  8. The circular ends of a bucket are of radii 35 cm and 14 cm and the height of the bucket is 40 cm. Its volume is  
(A)  $60060 \text{ cm}^3$                       (B)  $80080 \text{ cm}^3$                       (C)  $70040 \text{ cm}^3$                       (D)  $80160 \text{ cm}^3$
  9. If the radii of the ends of a bucket are 5 cm and 15 cm and it is 24 cm high, then its surface area is  
(A)  $1815.3 \text{ cm}^2$                       (B)  $1711.3 \text{ cm}^2$                       (C)  $2025.3 \text{ cm}^2$                       (D)  $2360 \text{ cm}^2$
  10. If the radii of the ends of a 42 cm high bucket are 16 cm and 11 cm, determine its capacity (take  $\pi = \frac{22}{7}$ )  
(A)  $24222 \text{ cm}^3$                       (B)  $24332 \text{ cm}^3$                       (C)  $24322 \text{ cm}^3$                       (D) none of these
- .....

**PRACTICE QUESTIONS**  
**CLASS X: CHAPTER – 13**  
**SURFACE AREAS AND VOLUMES**

1. A cone of maximum size is carved out from a cube of edge 14 cm. Find the surface area of the cone and of the remaining solid left out after the cone carved out.
2. A solid metallic sphere of radius 10.5 cm is melted and recast into a number of smaller cones, each of radius 3.5 cm and height 3 cm. Find the number of cones so formed.
3. A canal is 300 cm wide and 120 cm deep. The water in the canal is flowing with a speed of 20 km/h. How much area will it irrigate in 20 minutes if 8 cm of standing water is desired?
4. A cone of radius 4 cm is divided into two parts by drawing a plane through the mid point of its axis and parallel to its base. Compare the volumes of the two parts.
5. Three cubes of a metal whose edges are in the ratio 3:4:5 are melted and converted into a single cube whose diagonal is  $12\sqrt{3}$  cm. Find the edges of the three cubes.
6. Three metallic solid cubes whose edges are 3 cm, 4 cm and 5 cm are melted and formed into a single cube. Find the edge of the cube so formed.
7. How many shots each having diameter 3 cm can be made from a cuboidal lead solid of dimensions  $9\text{cm} \times 11\text{cm} \times 12\text{cm}$ ?
8. A bucket is in the form of a frustum of a cone and holds 28.490 litres of water. The radii of the top and bottom are 28 cm and 21 cm, respectively. Find the height of the bucket.
9. A cone of radius 8 cm and height 12 cm is divided into two parts by a plane through the mid-point of its axis parallel to its base. Find the ratio of the volumes of two parts.
10. Two identical cubes each of volume  $64\text{ cm}^3$  are joined together end to end. What is the surface area of the resulting cuboid?
11. From a solid cube of side 7 cm, a conical cavity of height 7 cm and radius 3 cm is hollowed out. Find the volume of the remaining solid.
12. Two cones with same base radius 8 cm and height 15 cm are joined together along their bases. Find the surface area of the shape so formed.
13. Two solid cones A and B are placed in a cylindrical tube as shown in the below figure. The ratio of their capacities is 2:1. Find the heights and capacities of cones. Also, find the volume of the remaining portion of the cylinder.

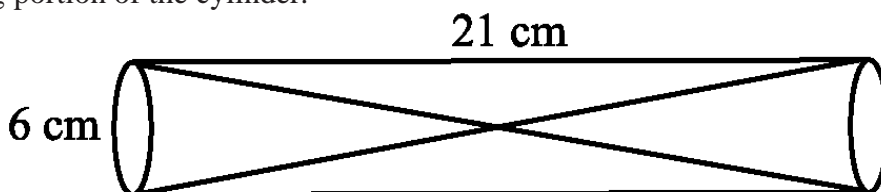

14. An ice cream cone full of ice cream having radius 5 cm and height 10 cm as shown in the below figure. Calculate the volume of ice cream, provided that its  $\frac{1}{6}$  part is left unfilled with ice cream.

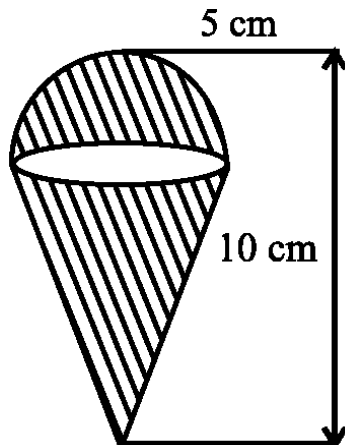

15. Marbles of diameter 1.4 cm are dropped into a cylindrical beaker of diameter 7 cm containing some water. Find the number of marbles that should be dropped into the beaker so that the water level rises by 5.6 cm.
16. How many spherical lead shots each of diameter 4.2 cm can be obtained from a solid rectangular lead piece with dimensions 66 cm, 42 cm and 21 cm.
17. How many spherical lead shots of diameter 4 cm can be made out of a solid cube of lead whose edge measures 44 cm.
18. A wall 24 m long, 0.4 m thick and 6 m high is constructed with the bricks each of dimensions 25 cm  $\times$  16 cm  $\times$  10 cm. If the mortar occupies  $\frac{1}{10}$ th of the volume of the wall, then find the number of bricks used in constructing the wall.
19. Find the number of metallic circular disc with 1.5 cm base diameter and of height 0.2 cm to be melted to form a right circular cylinder of height 10 cm and diameter 4.5 cm.
20. A bucket is in the form of a frustum of a cone of height 30 cm with radii of its lower and upper ends as 10 cm and 20 cm, respectively. Find the capacity and surface area of the bucket. Also, find the cost of milk which can completely fill the container, at the rate of Rs 25 per litre ( use  $\pi = 3.14$ ).
21. A solid toy is in the form of a hemisphere surmounted by a right circular cone. The height of the cone is 4 cm and the diameter of the base is 8 cm. Determine the volume of the toy. If a cube circumscribes the toy, then find the difference of the volumes of cube and the toy. Also, find the total surface area of the toy.
22. A solid metallic hemisphere of radius 8 cm is melted and recasted into a right circular cone of base radius 6 cm. Determine the height of the cone.
23. A rectangular water tank of base 11 m  $\times$  6 m contains water upto a height of 5 m. If the water in the tank is transferred to a cylindrical tank of radius 3.5 m, find the height of the water level in the tank.

24. A building is in the form of a cylinder surmounted by a hemispherical dome. The base diameter of the dome is equal to  $\frac{2}{3}$  of the total height of the building. Find the height of the building, if it contains  $67\frac{1}{21}$  m<sup>3</sup> of air.
25. How many cubic centimetres of iron is required to construct an open box whose external dimensions are 36 cm, 25 cm and 16.5 cm provided the thickness of the iron is 1.5 cm. If one cubic cm of iron weighs 7.5 g, find the weight of the box.
26. The barrel of a fountain pen, cylindrical in shape, is 7 cm long and 5 mm in diameter. A full barrel of ink in the pen is used up on writing 3300 words on an average. How many words can be written in a bottle of ink containing one fifth of a litre?
27. Water flows at the rate of 10m/minute through a cylindrical pipe 5 mm in diameter. How long would it take to fill a conical vessel whose diameter at the base is 40 cm and depth 24 cm?
28. A heap of rice is in the form of a cone of diameter 9 m and height 3.5 m. Find the volume of the rice. How much canvas cloth is required to just cover the heap?
29. A factory manufactures 120000 pencils daily. The pencils are cylindrical in shape each of length 25 cm and circumference of base as 1.5 cm. Determine the cost of colouring the curved surfaces of the pencils manufactured in one day at Rs 0.05 per dm<sup>2</sup>.
30. Water is flowing at the rate of 15 km/h through a pipe of diameter 14 cm into a cuboidal pond which is 50 m long and 44 m wide. In what time will the level of water in pond rise by 21 cm?
31. A solid iron cuboidal block of dimensions 4.4 m × 2.6 m × 1m is recast into a hollow cylindrical pipe of internal radius 30 cm and thickness 5 cm. Find the length of the pipe.
32. 500 persons are taking a dip into a cuboidal pond which is 80 m long and 50 m broad. What is the rise of water level in the pond, if the average displacement of the water by a person is 0.04m<sup>3</sup>?
33. 16 glass spheres each of radius 2 cm are packed into a cuboidal box of internal dimensions 16 cm × 8 cm × 8 cm and then the box is filled with water. Find the volume of water filled in the box.
34. A milk container of height 16 cm is made of metal sheet in the form of a frustum of a cone with radii of its lower and upper ends as 8 cm and 20 cm respectively. Find the cost of milk at the rate of Rs. 22 per litre which the container can hold.
35. A cylindrical bucket of height 32 cm and base radius 18 cm is filled with sand. This bucket is emptied on the ground and a conical heap of sand is formed. If the height of the conical heap is 24 cm, find the radius and slant height of the heap.
36. A rocket is in the form of a right circular cylinder closed at the lower end and surmounted by a cone with the same radius as that of the cylinder. The diameter and height of the cylinder are 6 cm and 12 cm, respectively. If the slant height of the conical portion is 5 cm, find the total surface area and volume of the rocket [Use  $\pi = 3.14$ ].
37. A building is in the form a cylinder surmounted by a hemispherical vaulted dome and contains  $41\frac{19}{21}$  m<sup>3</sup> of air. If the internal diameter of dome is equal to its total height above the floor, find the height of the building?

38. A hemispherical bowl of internal radius 9 cm is full of liquid. The liquid is to be filled into cylindrical shaped bottles each of radius 1.5 cm and height 4 cm. How many bottles are needed to empty the bowl?
39. A solid right circular cone of height 120 cm and radius 60 cm is placed in a right circular cylinder full of water of height 180 cm such that it touches the bottom. Find the volume of water left in the cylinder, if the radius of the cylinder is equal to the radius of the cone.
40. Water flows through a cylindrical pipe, whose inner radius is 1 cm, at the rate of 80 cm/sec in an empty cylindrical tank, the radius of whose base is 40 cm. What is the rise of water level in tank in half an hour?
41. The rain water from a roof of dimensions 22 m 20 m drains into a cylindrical vessel having diameter of base 2 m and height 3.5 m. If the rain water collected from the roof just fill the cylindrical vessel, then find the rainfall in cm.
42. A pen stand made of wood is in the shape of a cuboid with four conical depressions and a cubical depression to hold the pens and pins, respectively. The dimension of the cuboid are 10 cm, 5 cm and 4 cm. The radius of each of the conical depressions is 0.5 cm and the depth is 2.1 cm. The edge of the cubical depression is 3 cm. Find the volume of the wood in the entire stand.
43. A cone of radius 10cm is divided into two parts by drawing a plane through the midpoint of its axis, parallel to its base. Compare the volume of the two parts.
44. A hollow cone is cut by a plane parallel to the base and the upper portion is removed. If the curved surface of the remainder is  $\frac{8}{9}$  of the curved surface of the whole cone. Find the ratio of the line segments into which the cone's altitude is divided by the plane.
45. From a solid cylinder of height 24cm and diameter 10cm, two conical cavities of same radius as that of the cylinder are hollowed out. If the height of each conical activity is half the height of cylinder, find the total surface area of the remaining cylinder.
46. A farmer connects a pipe of internal diameter 20cm from a canal into a cylindrical tank to her field, which is 10m in diameter and 2m deep. If water flows through the pipe at the rate of 3km/hr, in how much time will the tank be filled?
47. A toy is in the form of a cone on a hemi-sphere of diameter 7 cm. The total height of the top is 14.5cm. Find the volume and total surface area of the toy.
48. A vessel in the form of hemi-spherical is mounted by a hollow cylinder. The diameter of the bowl is 14cm and the total height of the vessel is 13 cm. Find the capacity of the vessel.
49. A cylindrical with radius and height is 4cm and 8cm is filled with Ice-cream and ice-cream is distributed to 10 Children in equal can having hemi-spherical tops. If the height of the conical portion is 4 times the radius of its base, find the radius of the ice-cream cone.
50. A tent has cylindrical surmounted by a conical roof. The radius of the cylindrical base is 20m. The total height of tent is 6.3m and height of cylindrical portion is 4.2m, find the volume and surface area of tent.
51. Rasheed got a playing top (*lattu*) as his birthday present, which surprisingly had no colour on it. He wanted to colour it with his crayons. The top is shaped like a cone surmounted by a

hemisphere. The entire top is 5 cm in height and the diameter of the top is 3.5 cm. Find the area he has to colour. (Take  $\pi = 22/7$ )

52. A wooden toy rocket is in the shape of a cone mounted on a cylinder. The height of the entire rocket is 26 cm, while the height of the conical part is 6 cm. The base of the conical portion has a diameter of 5 cm, while the base diameter of the cylindrical portion is 3 cm. If the conical portion is to be painted orange and the cylindrical portion yellow, find the area of the rocket painted with each of these colours. (Take  $\pi = 3.14$ )
53. A toy is in the form of a cone of radius 3.5 cm mounted on a hemisphere of same radius. The total height of the toy is 15.5 cm. Find the total surface area of the toy.
54. A tent is in the shape of a cylinder surmounted by a conical top. If the height and diameter of the cylindrical part are 2.1 m and 4 m respectively, and the slant height of the top is 2.8 m, find the area of the canvas used for making the tent. Also, find the cost of the canvas of the tent at the rate of Rs 500 per  $\text{m}^2$
55. From a solid cylinder whose height is 2.4 cm and diameter 1.4 cm, a conical cavity of the same height and same diameter is hollowed out. Find the total surface area of the remaining solid to the nearest  $\text{cm}^2$ .
56. A juice seller was serving his customers using glasses. The inner diameter of the cylindrical glass was 5 cm, but the bottom of the glass had a hemispherical raised portion which reduced the capacity of the glass. If the height of a glass was 10 cm, find the apparent capacity of the glass and its actual capacity. (Take  $\pi = 3.14$ )
57. A solid toy is in the form of a hemisphere surmounted by a right circular cone. The height of the cone is 2 cm and the diameter of the base is 4 cm. Determine the volume of the toy. If a right circular cylinder circumscribes the toy, find the difference of the volumes of the cylinder and the toy. (Take  $\pi = 3.14$ )
58. A *gulab jamun*, contains sugar syrup up to about 30% of its volume. Find approximately how much syrup would be found in 45 *gulab jamuns*, each shaped like a cylinder with two hemispherical ends with length 5 cm and diameter 2.8 cm.
59. A pen stand made of wood is in the shape of a cuboid with four conical depressions to hold pens. The dimensions of the cuboid are 15 cm by 10 cm by 3.5 cm. The radius of each of the depressions is 0.5 cm and the depth is 1.4 cm. Find the volume of wood in the entire stand.
60. A vessel is in the form of an inverted cone. Its height is 8 cm and the radius of its top, which is open, is 5 cm. It is filled with water up to the brim. When lead shots, each of which is a sphere of radius 0.5 cm are dropped into the vessel, one-fourth of the water flows out. Find the number of lead shots dropped in the vessel.
61. A solid iron pole consists of a cylinder of height 220 cm and base diameter 24 cm, which is surmounted by another cylinder of height 60 cm and radius 8 cm. Find the mass of the pole, given that  $1 \text{ cm}^3$  of iron has approximately 8g mass. (Use  $\pi = 3.14$ )
62. A solid consisting of a right circular cone of height 120 cm and radius 60 cm standing on a hemisphere of radius 60 cm is placed upright in a right circular cylinder full of water such that it touches the bottom. Find the volume of water left in the cylinder, if the radius of the cylinder is 60 cm and its height is 180 cm.



63. A spherical glass vessel has a cylindrical neck 8 cm long, 2 cm in diameter; the diameter of the spherical part is 8.5 cm. By measuring the amount of water it holds, a child finds its volume to be 345 cm<sup>3</sup>. Check whether she is correct, taking the above as the inside measurements, and  $\pi = 3.14$ .
64. A cone of height 24 cm and radius of base 6 cm is made up of modeling clay. A child reshapes it in the form of a sphere. Find the radius of the sphere.
65. Selvi's house has an overhead tank in the shape of a cylinder. This is filled by pumping water from a sump (an underground tank) which is in the shape of a cuboid. The sump has dimensions 1.57 m  $\times$  1.44 m  $\times$  95 cm. The overhead tank has its radius 60 cm and height 95 cm. Find the height of the water left in the sump after the overhead tank has been completely filled with water from the sump which had been full. Compare the capacity of the tank with that of the sump. (Use  $\pi = 3.14$ )
66. A copper rod of diameter 1 cm and length 8 cm is drawn into a wire of length 18 m of uniform thickness. Find the thickness of the wire.
67. A hemispherical tank full of water is emptied by a pipe at the rate of  $3\frac{4}{7}$  litres per second. How much time will it take to empty half the tank, if it is 3 m in diameter? (Take  $\pi = 22/7$ )
68. A 20 m deep well with diameter 7 m is dug and the earth from digging is evenly spread out to form a platform 22 m by 14 m. Find the height of the platform.
69. A well of diameter 3 m is dug 14 m deep. The earth taken out of it has been spread evenly all around it in the shape of a circular ring of width 4 m to form an embankment. Find the height of the embankment.
70. A container shaped like a right circular cylinder having diameter 12 cm and height 15 cm is full of ice cream. The ice cream is to be filled into cones of height 12 cm and diameter 6 cm, having a hemispherical shape on the top. Find the number of such cones which can be filled with ice cream.
71. How many silver coins, 1.75 cm in diameter and of thickness 2 mm, must be melted to form a cuboid of dimensions 5.5 cm  $\times$  10 cm  $\times$  3.5 cm?
72. A cylindrical bucket, 32 cm high and with radius of base 18 cm, is filled with sand. This bucket is emptied on the ground and a conical heap of sand is formed. If the height of the conical heap is 24 cm, find the radius and slant height of the heap.
73. Water in a canal, 6 m wide and 1.5 m deep, is flowing with a speed of 10 km/h. How much area will it irrigate in 30 minutes, if 8 cm of standing water is needed?
74. A farmer connects a pipe of internal diameter 20 cm from a canal into a cylindrical tank in her field, which is 10 m in diameter and 2 m deep. If water flows through the pipe at the rate of 3 km/h, in how much time will the tank be filled?
75. Hanumappa and his wife Gangamma are busy making jaggery out of sugarcane juice. They have processed the sugarcane juice to make the molasses, which is poured into moulds in the shape of a frustum of a cone having the diameters of its two circular faces as 30 cm and 35 cm and the vertical height of the mould is 14 cm. If each cm<sup>3</sup> of molasses has mass about 1.2 g, find the mass of the molasses that can be poured into each mould. (Take  $\pi = 22/7$ )
76. An open metal bucket is in the shape of a frustum of a cone, mounted on a hollow cylindrical base ~~made of the same metallic sheet. The diameters of the two circular ends of the bucket are 45 cm~~

and 25 cm, the total vertical height of the bucket is 40 cm and that of the cylindrical base is 6 cm. Find the area of the metallic sheet used to make the bucket, where we do not take into account the handle of the bucket. Also, find the volume of water the bucket can hold.

77. A container, opened from the top and made up of a metal sheet, is in the form of a frustum of a cone of height 16 cm with radii of its lower and upper ends as 8 cm and 20 cm, respectively. Find the cost of the milk which can completely fill the container, at the rate of Rs 20 per litre. Also find the cost of metal sheet used to make the container, if it costs Rs 8 per 100 cm<sup>2</sup>. (Take  $\pi = 3.14$ )
78. A metallic right circular cone 20 cm high and whose vertical angle is  $60^\circ$  is cut into two parts at the middle of its height by a plane parallel to its base. If the frustum so obtained be drawn into a wire of diameter  $\frac{1}{16}$  cm, find the length of the wire.
79. A right triangle, whose sides are 3 cm and 4 cm (other than hypotenuse) is made to revolve about its hypotenuse. Find the volume and surface area of the double cone so formed.
80. The decorative block shown in Fig. is made of two solids - a cube and a hemisphere. The base of the block is a cube with edge 5 cm, and the hemisphere fixed on the top has a diameter of 4.2 cm. Find the total surface area of the block. (Take  $\pi = 22/7$ ).

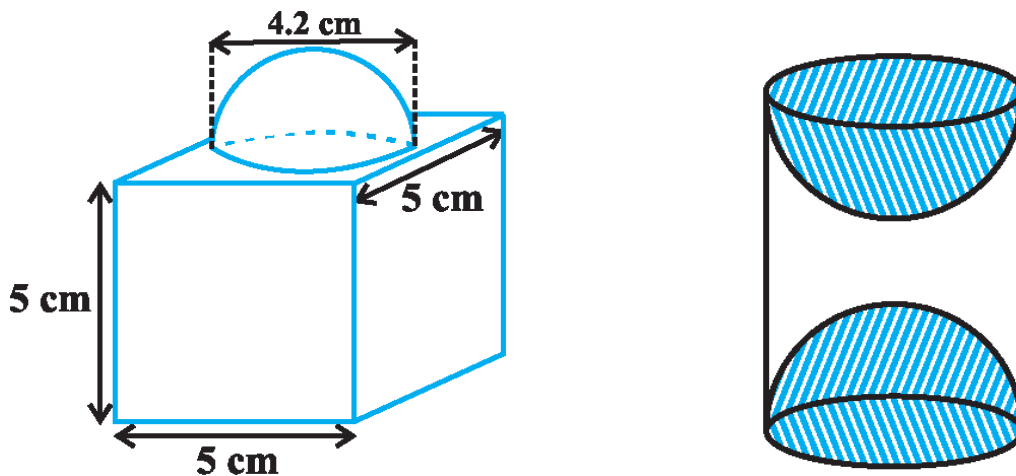

81. A wooden article was made by scooping out a hemisphere from each end of a solid cylinder, as shown in above Fig.. If the height of the cylinder is 10 cm, and its base is of radius 3.5 cm, find the total surface area of the article.
82. A sphere of diameter 12 cm, is dropped in a right circular cylindrical vessel, partly filled with water. If the sphere is completely submerged in water level in the cylindrical vessel rises by  $3\frac{5}{9}$  cm. find the diameter of the cylindrical vessel.
83. An iron pillar has lower part in the form of a right circular cylinder and the upper part is in the form of a right circular cone. The radius of the base of the cone and cylinder is 8cm. The cylindrical part is 240cm high and the conical part is 36cm high. Find the weight of the pillar if  $1 \text{ cm}^3$  of iron weighs 7.5 grams.
84. An oil funnel made of tin sheet consists of a 10 cm long cylindrical portion attached to a frustum of a cone. If the total height is 22 cm, diameter of the cylindrical portion is 8 cm and the diameter of the top of the funnel is 18 cm, find the area of the tin sheet required to make the funnel (see below figure)

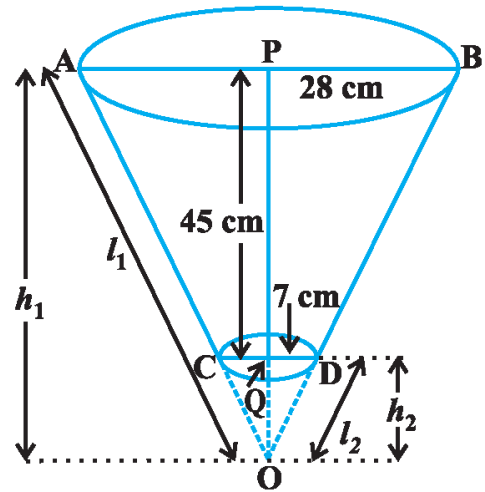
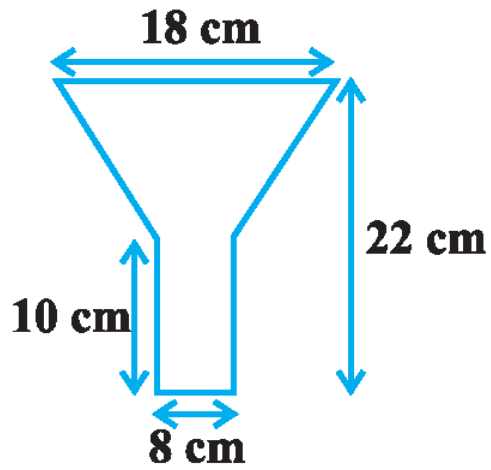

85. The radii of the ends of a frustum of a cone 45 cm high are 28 cm and 7 cm (see above sided Fig). Find its volume, the curved surface area and the total surface area. (Take  $\pi = 22/7$ )

# CLASS X: CHAPTER - 14 STATISTICS

## IMPORTANT FORMULAS & CONCEPTS

In many real-life situations, it is helpful to describe data by a single number that is most representative of the entire collection of numbers. Such a number is called a **measure of central tendency**. The most commonly used measures are as follows.

1. The **mean**, or **average**, of 'n' numbers is the sum of the numbers divided by n.
2. The **median** of 'n' numbers is the middle number when the numbers are written in order. If n is even, the median is the average of the two middle numbers.
3. The **mode** of 'n' numbers is the number that occurs most frequently. If two numbers tie for most frequent occurrence, the collection has two modes and is called **bimodal**.

### MEAN OF GROUPED DATA

#### Direct method

$$\text{Mean, } \bar{x} = \frac{\sum f_i x_i}{\sum f_i}$$

#### Assume mean method or Short-cut method

$$\text{Mean, } \bar{x} = A + \frac{\sum f_i d_i}{\sum f_i} \text{ where } d_i = x_i - A$$

#### Step Deviation method

$$\text{Mean, } \bar{x} = A + \frac{\sum f_i u_i}{\sum f_i} \times h \text{ where } u = \frac{x_i - A}{h}$$

### MODE OF GROUPED DATA

$$\text{Mode} = l + \left( \frac{f_1 - f_0}{2f_1 - f_0 - f_2} \right) \times h$$

where  $l$  = lower limit of the modal class,

$h$  = size of the class interval (assuming all class sizes to be equal),

$f_1$  = frequency of the modal class,

$f_0$  = frequency of the class preceding the modal class,

$f_2$  = frequency of the class succeeding the modal class.

- **Cumulative Frequency:** The cumulative frequency of a class is the frequency obtained by adding the frequencies of all the classes preceding the given class.

### MEDIAN OF GROUPED DATA

$$\text{Median} = l + \left( \frac{\frac{n}{2} - cf}{f} \right) \times h$$

where  $l$  = lower limit of median class,

$n$  = number of observations,

$cf$  = cumulative frequency of class preceding the median class,

$f$  = frequency of median class,

$h$  = class size (assuming class size to be equal).

## EMPIRICAL FORMULA

$$3\text{Median} = \text{Mode} + 2 \text{ Mean}$$

❖ Cumulative frequency curve is also known as 'Ogive'.

There are three methods of drawing ogive:

### 1. LESS THAN METHOD

*Steps involved in calculating median using less than Ogive approach-*

- Convert the series into a 'less than' cumulative frequency distribution.
- Let  $N$  be the total number of students whose data is given.  $N$  will also be the cumulative frequency of the last interval. Find the  $(N/2)^{\text{th}}$  item and mark it on the y-axis.
- Draw a perpendicular from that point to the right to cut the Ogive curve at point A.
- From point A where the Ogive curve is cut, draw a perpendicular on the x-axis. The point at which it touches the x-axis will be the median value of the series as shown in the graph.

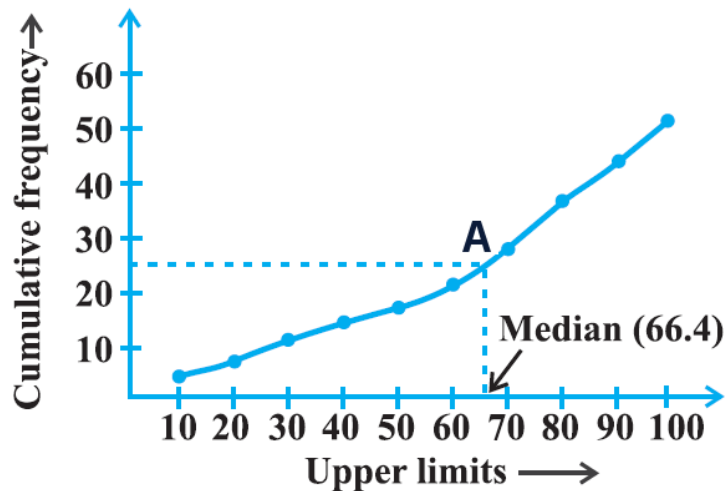

### 2. MORE THAN METHOD

*Steps involved in calculating median using more than Ogive approach-*

- Convert the series into a 'more than' cumulative frequency distribution.
- Let  $N$  be the total number of students whose data is given.  $N$  will also be the cumulative frequency of the last interval. Find the  $(N/2)^{\text{th}}$  item and mark it on the y-axis.
- Draw a perpendicular from that point to the right to cut the Ogive curve at point A.
- From point A where the Ogive curve is cut, draw a perpendicular on the x-axis. The point at which it touches the x-axis will be the median value of the series as shown in the graph.

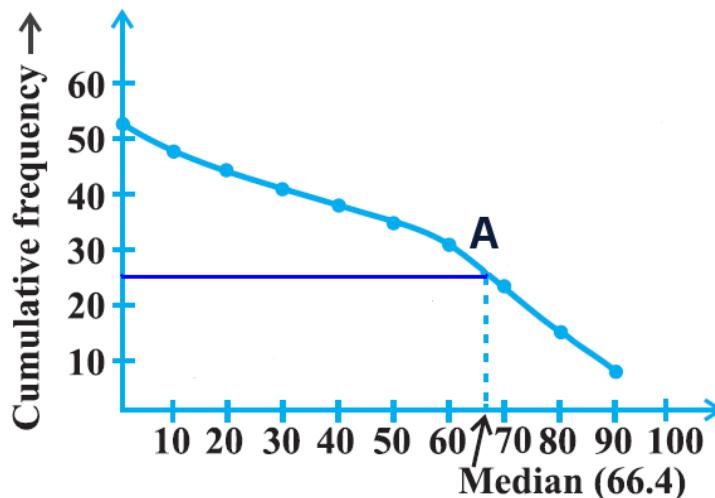

### 3. LESS THAN AND MORE THAN OGIVE METHOD

Another way of graphical determination of median is through simultaneous graphic presentation of both the less than and more than Ogives.

- Mark the point A where the Ogive curves cut each other.
- Draw a perpendicular from A on the x-axis. The corresponding value on the x-axis would be the median value.

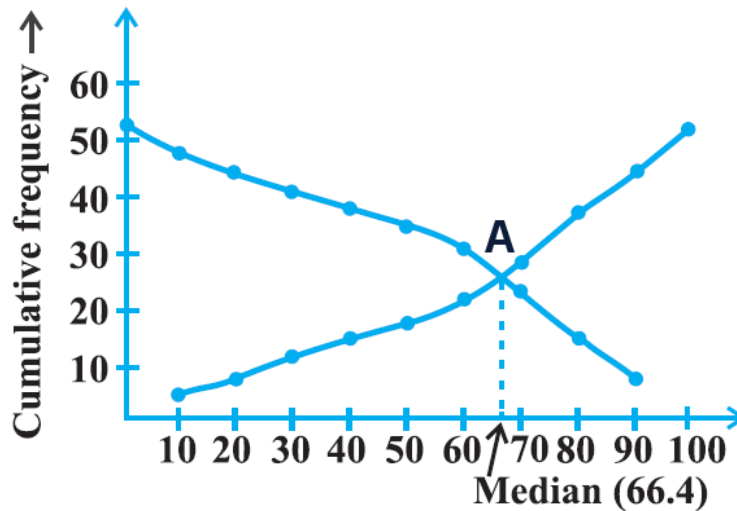

- ❖ The median of grouped data can be obtained graphically as the  $x$ -coordinate of the point of intersection of the two ogives for this data.

**MCQ WORKSHEET-I**  
**CLASS X: CHAPTER - 14**  
**STATISTICS**

- For a frequency distribution, mean, median and mode are connected by the relation  
(a) mode = 3mean – 2median (b) mode = 2median – 3mean  
(c) mode = 3median – 2mean (d) mode = 3median + 2mean
- Which measure of central tendency is given by the x – coordinate of the point of intersection of the more than ogive and less than ogive?  
(a) mode (b) median (c) mean (d) all the above three measures
- The class mark of a class interval is  
(a) upper limit + lower limit (b) upper limit – lower limit  
(c)  $\frac{1}{2}$  (upper limit + lower limit) (d)  $\frac{1}{2}$  (upper limit – lower limit)
- Construction of cumulative frequency table is useful in determining the  
(a) mode (b) median (c) mean (d) all the above three measures
- For the following distribution

Marks	Number of students
Below 10	3
Below 20	12
Below 30	27
Below 40	57
Below 50	75
Below 60	80

the modal class is

- (a) 10 – 20 (b) 20 – 30 (c) 30 – 40 (d) 40 – 50
- For the following distribution

Marks	Number of students
Below 10	3
Below 20	12
Below 30	27
Below 40	57
Below 50	75
Below 60	80

the median class is

- (a) 10 – 20 (b) 20 – 30 (c) 30 – 40 (d) 40 – 50
- In a continuous frequency distribution, the median of the data is 24. If each item is increased by 2, then the new median will be  
(a) 24 (b) 26 (c) 12 (d) 48
  - In a grouped frequency distribution, the mid values of the classes are used to measure which of the following central tendency?  
(a) mode (b) median (c) mean (d) all the above three measures
  - Which of the following is not a measure of central tendency of a statistical data?  
(a) mode (b) median (c) mean (d) range
  - Weights of 40 eggs were recorded as given below:

Weights(in gms)	85 – 89	90 – 94	95 – 99	100 – 104	105- 109
No. of eggs	10	12	12	4	2

The lower limit of the median class is

- (a) 90 (b) 95 (c) 94.5 (d) 89.5

**MCQ WORKSHEET-II**  
**CLASS X: CHAPTER - 14**  
**STATISTICS**

1. The median class of the following distribution is

C.I	0 – 10	10 – 20	20 – 30	30 – 40	40 – 50	50 – 60
F	8	10	12	22	30	18

- (a) 10 – 20      (b) 20 – 30      (c) 30 – 40      (d) 40 – 50

2. Weights of 40 eggs were recorded as given below:

Weights(in gms)	85 – 89	90 – 94	95 – 99	100 – 104	105- 109
No. of eggs	10	12	15	4	2

The lower limit of the modal class is

- (a) 90      (b) 95      (c) 94.5      (d) 89.5

3. The arithmetic mean of 12 observations is 7.5. If the arithmetic mean of 7 of these observations is 6.5, the mean of the remaining observations is

- (a) 5.5      (b) 8.5      (c) 8.9      (d) 9.2

4. In a continuous frequency distribution, the mean of the data is 25. If each item is increased by 5, then the new median will be

- (a) 25   (b) 30   (c) 20   (d) none of these

5. In a continuous frequency distribution with usual notations, if  $l = 32.5$ ,  $f_1 = 15$ ,  $f_0 = 12$ ,  $f_2 = 8$  and  $h = 8$ , then the mode of the data is

- (a) 32.5      (b) 33.5      (c) 33.9      (d) 34.9

6. The arithmetic mean of the following frequency distribution is 25, then the value of p is

C.I	0 – 10	10 – 20	20 – 30	30 – 40	40 – 50
F	5	18	15	p	6

- (a) 12      (b) 16      (c) 18      (d) 20

7. If the mean of the following frequency distribution is 54, then the value of p is

C.I	0 – 20	20 – 40	40 – 60	60 – 80	80 – 100
F	7	p	10	9	13

- (a) 12      (b) 16      (c) 18      (d) 11

8. The mean of the following frequency distribution is

C.I	0 – 10	10 – 20	20 – 30	30 – 40	40 – 50
F	12	16	6	7	9

- (a) 12      (b) 16      (c) 22      (d) 20

9. The mean of the following frequency distribution is

C.I	0 – 10	10 – 20	20 – 30	30 – 40	40 – 50
F	7	8	12	13	10

- (a) 12.2      (b) 16.2      (c) 22.2      (d) 27.2

10. The median of the following frequency distribution is

C.I	100 – 150	150 – 200	200 – 250	250 – 300	300 – 350
F	6	3	5	20	10

- (a) 120      (b) 160      (c) 220      (d) 270



**MCQ WORKSHEET-III**  
**CLASS X: CHAPTER - 14**  
**STATISTICS**

1. The range of the data 14, 27, 29, 61, 45, 15, 9, 18 is  
(a) 61            (b) 52            (c) 47            (d) 53
2. The class mark of the class 120 – 150 is  
(a) 120            (b) 130            (c) 135            (d) 150
3. The class mark of a class is 10 and its class width is 6. The lower limit of the class is  
(a) 5                (b) 7                (c) 8                (d) 10
4. In a frequency distribution, the class width is 4 and the lower limit of first class is 10. If there are six classes, the upper limit of last class is  
(a) 22            (b) 26            (c) 30            (d) 34
5. The class marks of a distribution are 15, 20, 25,.....45. The class corresponding to 45 is  
(a) 12.5 – 17.5            (b) 22.5 – 27.5            (c) 42.5 – 47.5            (d) none of these
6. The number of students in which two classes are equal.  
(a) VI and VIII            (b) VI and VII            (c) VII and VIII            (d) none of these

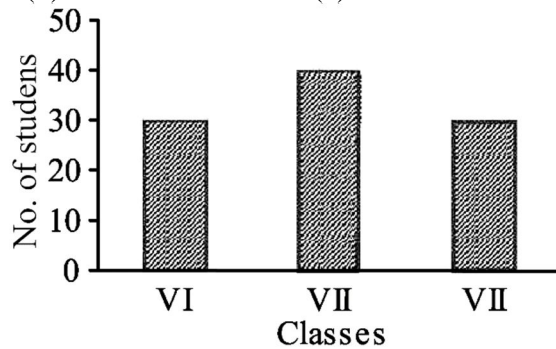

7. The mean of first five prime numbers is  
(a) 5.0            (b) 4.5            (c) 5.6            (d) 6.5
8. The mean of first ten multiples of 7 is  
(a) 35.0            (b) 36.5            (c) 38.5            (d) 39.2
9. The mean of  $x + 3$ ,  $x - 2$ ,  $x + 5$ ,  $x + 7$  and  $x + 72$  is  
(a)  $x + 5$             (b)  $x + 2$             (c)  $x + 3$             (d)  $x + 7$
10. If the mean of  $n$  observations  $x_1, x_2, x_3, \dots, x_n$  is  $\bar{x}$  then  $\sum_{i=1}^n x_i - \bar{x}$  is  
(a) 1                (b) -1                (c) 0                (d) cannot be found
11. The mean of 10 observations is 42. If each observation in the data is decreased by 12, the new mean of the data is  
(a) 12                (b) 15                (c) 30                (d) 54
12. The median of 10, 12, 14, 16, 18, 20 is  
(a) 12                (b) 14                (c) 15                (d) 16

13. If the median of 12, 13, 16,  $x + 2$ ,  $x + 4$ , 28, 30, 32 is 23, when  $x + 2$ ,  $x + 4$  lie between 16 and 30, then the value of  $x$  is

- (a) 18            (b) 19            (c) 20            (d) 22

14. If the mode of 12, 16, 19, 16,  $x$ , 12, 16, 19, 12 is 16, then the value of  $x$  is

- (a) 12            (b) 16            (c) 19            (d) 18

15. The mean of the following data is

<b>x</b>	5	10	15	20	25
<b>f</b>	3	5	8	3	1

- (a) 12            (b) 13            (c) 13.5            (d) 13.6

16. The mean of 10 numbers is 15 and that of another 20 number is 24 then the mean of all 30 observations is

- (a) 20            (b) 15            (c) 21            (d) 24



**MCQ WORKSHEET-IV**  
**CLASS X: CHAPTER - 14**  
**STATISTICS**

- Construction of cumulative frequency table is useful in determining the  
 (a) mean (b) median (c) mode (d) all three
- In the formula  $\bar{x} = a + \frac{\sum f_i d_i}{\sum f_i}$ , finding the mean of the grouped data,  $d_i$ 's are deviations from assumed mean 'a' of  
 (a) lower limits of classes (b) upper limits of classes  
 (c) class marks (d) frequencies of the classes.
- If  $x_i$ 's are the midpoints of the class intervals of grouped data,  $f_i$ 's are the corresponding frequencies and  $\bar{x}$  is the mean, then  $\sum f_i (x_i - \bar{x})$  is equal to  
 (a) 0 (b) -1 (c) 1 (d) 2
- In the formula  $\bar{x} = a + \left( \frac{\sum f_i u_i}{\sum f_i} \times h \right)$ , finding the mean of the grouped data,  $u_i =$   
 (a)  $\frac{x_i + a}{h}$  (b)  $\frac{x_i - a}{h}$  (c)  $\frac{a - x_i}{h}$  (d)  $h(x_i - a)$

5. For the following distribution:

<b>Class</b>	0-5	5-10	10-15	15-20	20-25
<b>Frequency</b>	10	15	12	20	9

The sum of lower limits of the median class and the modal class is

- (a) 15 (b) 25 (c) 30 (d) 35
- Consider the following frequency distribution:

<b>Class</b>	0-9	10-19	20-29	30-39	40-49
<b>Frequency</b>	13	10	15	8	11

The upper limit of the median class is

- (a) 29 (b) 29.5 (c) 30 (d) 19.5

- The abscissa of the point of intersection of the less than type and of the more than type ogives gives its  
 (a) mean (b) median (c) mode (d) all three

8. For the following distribution: the modal class is

<b>Marks</b>	Below 10	Below 20	Below 30	Below 40	Below 50
<b>No. of Students</b>	8	17	32	62	80

- (a) 10 – 20 (b) 20 – 30 (c) 30 – 40 (d) 40 – 50

9. From the following data of the marks obtained by students of class X

<b>Marks</b>	0-10	10-20	20-30	30-40	40-50	50-60
<b>No. of Students</b>	8	12	20	30	10	10

How many students, secured less than 40 marks?

- (a) 70 (b) 40 (c) 80 (d) 30

10. The times in seconds taken by 150 athletics to run a 100m hurdle race are given as under:

<b>Class</b>	12.7-13	13-13.3	13.3-13.6	13.6-13.9	13.9-13.12
<b>Frequency</b>	5	6	10	55	41

The number of athletes who completed the race in less than 13.9 sec is

- (a) 21            (b) 55            (c) 41            (d) 76

11. Consider the data:

<b>Class</b>	25-45	45-65	65-85	85-105	105-125	125-145
<b>Frequency</b>	4	5	12	20	14	11

The difference of the upper limit of the median class and the lower limit of the modal class is

- (a) 0            (b) 19            (c) 20            (d) 38

12. Consider the following distribution:

<b>Marks</b>	Above 0	Above 10	Above 20	Above 30	Above 40	Above 50
<b>No. of Students</b>	63	58	55	51	48	42

The frequency of the class 30 – 40 is

- (a) 3            (b) 4            (c) 48            (d) 41



**PRACTICE QUESTIONS**  
**CLASS X: CHAPTER - 14**  
**STATISTICS**  
**MEAN BASED QUESTIONS**

1. Is it true to say that the mean, mode and median of grouped data will always be different. Justify your answer.
2. The mean of ungrouped data and the mean calculated when the same data is grouped are always the same. Do you agree with this statement? Give reason for your answer.

3. Find the mean of the distribution:

<b>Class</b>	1-3	3-5	5-7	7-9
<b>Frequency</b>	9	22	27	17

4. Daily wages of 110 workers, obtained in a survey, are tabulated below:

<b>Daily wages (in Rs.)</b>	100 - 120	120 - 140	140 - 160	160 - 180	180 - 200	200 - 220
<b>No. of workers</b>	15	18	25	22	18	12

Determine the mean wages of workers.

5. Calculate the mean of the scores of 20 students in a mathematics test :

<b>Marks</b>	0-10	10-20	20-30	30-40	40-50
<b>No. of Students</b>	2	4	7	6	1

6. Calculate the mean of the following data :

<b>Class</b>	4-7	8-11	12-15	16-19
<b>Frequency</b>	5	4	9	10

7. The following table gives the number of pages written by Sarika for completing her own book for 30 days :

<b>No. of pages written per day</b>	16-18	19-21	22-24	25-27	28-30
<b>No. of days</b>	1	3	4	9	13

Find the mean number of pages written per day.

8. The daily income of a sample of 50 employees are tabulated as follows :

<b>Income(in Rs.)</b>	1-200	201-400	401-600	601-800
<b>No. of employees</b>	14	15	14	7

9. The weights (in kg) of 50 wrestlers are recorded in the following table :

<b>Weight(in kg)</b>	100-110	110-120	120-130	130-140	140-150
<b>No. of wrestlers</b>	4	14	21	8	3

Find the mean weight of the wrestlers.

10. An aircraft has 120 passenger seats. The number of seats occupied during 100 flights is given below:

<b>No. of seats</b>	100-104	104-108	108-112	112-116	116-120
<b>Frequency</b>	15	20	32	18	15

Determine the mean number of seats occupied over the flights

11. The mileage (km per litre) of 50 cars of the same model was tested by a manufacturer and details are tabulated as given below :

<b>Mileage(km/l)</b>	10-12	12-14	14-16	16-18
<b>No. of cars</b>	7	12	18	13

Find the mean mileage. The manufacturer claimed that the mileage of the model was 16 km/litre. Do you agree with this claim?

12. The following table shows the cumulative frequency distribution of marks of 800 students in an examination:

<b>Marks</b>	Below 10	Below 20	Below 30	Below 40	Below 50	Below 60	Below 70	Below 80	Below 90	Below 100
<b>No. of Students</b>	8	17	32	62	80	80	80	80	80	80

Find the mean marks.

13. The following is the cumulative frequency distribution (of less than type) of 1000 persons each of age 20 years and above. Determine the mean age.

<b>Age Below(in years)</b>	30	40	50	60	70	80
<b>No. of persons</b>	100	220	350	750	950	1000

14. Find the mean marks of students for the following distribution :

<b>Marks Above</b>	0	10	20	30	40	50	60	70	80	90	100
<b>No. of Students</b>	80	77	72	65	55	43	28	16	10	8	0

15. Determine the mean of the following distribution :

<b>Marks Below</b>	10	20	30	40	50	60	70	80	90	100
<b>No. of Students</b>	5	9	17	29	45	60	70	78	83	85

16. Find the mean age of 100 residents of a town from the following data :

<b>Age equal and above(in years)</b>	0	10	20	30	40	50	60	70
<b>No. of Persons</b>	100	90	75	50	25	15	5	0

17. Find the mean weights of tea in 70 packets shown in the following table :

<b>Weight(in gm)</b>	200-201	201-202	202-203	203-204	204-205	205-206
<b>No. of packets</b>	13	27	18	10	1	1

18. Find the mean of the following distribution :

<b>Class</b>	0-20	20-40	40-60	60-80	80-100	100-120	120-140
<b>Frequency</b>	12	18	15	25	26	15	9

19. Find the mean age from the following distribution :

<b>Age(in years)</b>	25-29	30-34	35-39	40-44	45-49	50-54	55-59
<b>No. of persons</b>	4	14	22	16	6	5	3

20. Find the mean age of the patients from the following distribution :

<b>Age(in years)</b>	5-14	15-24	25-34	35-44	45-54	55-64
<b>No. of patients</b>	6	11	21	23	14	5

**PRACTICE QUESTIONS**  
**CLASS X: CHAPTER - 14**  
**STATISTICS**  
**MEDIAN BASED QUESTIONS**

1. The median of an ungrouped data and the median calculated when the same data is grouped are always the same. Do you think that this is a correct statement? Give Reason.

2. The percentage of marks obtained by 100 students in an examination are given below:

<b>Marks</b>	30-35	35-40	40-45	45-50	50-55	55-60	60-65
<b>No. of Students</b>	14	16	18	23	18	8	3

Determine the median percentage of marks.

3. Weekly income of 600 families is as under:

<b>Income(in Rs.)</b>	0-1000	1000-2000	2000-3000	3000-4000	4000-5000	5000-6000
<b>No. of Families</b>	250	190	100	40	15	5

Compute the median income.

4. Find the median of the following frequency distribution:

<b>Marks</b>	0 – 5	5 – 10	10 – 15	15 – 20	20 – 25	25 – 30	30 – 35	35 – 40
<b>Number of students</b>	8	12	20	12	18	13	10	7

5. The following table gives the distribution of the life time of 500 neon lamps:

<b>Life time (in hrs)</b>	1500 – 2000	2000 – 2500	2500 – 3000	3000 – 3500	3500 – 4000	4000 – 4500	4500 – 5000
<b>Number of Lamps</b>	24	86	90	115	95	72	18

Find the median life time of a lamp.

6. The lengths of 40 leaves of a plant are measured correct to the nearest millimetre, and the data obtained is represented in the following table. Find the median length of the leaves.

<b>Length(in mm)</b>	118-126	127-135	136-144	145-153	154-162	163-171	172-180
<b>No. of leaves</b>	3	5	9	12	5	4	2

7. Find the median of the following frequency distribution:

<b>Class</b>	75-84	85-94	95-104	105-114	115-124	125-134	135-144
<b>Frequency</b>	8	11	26	31	18	4	2

8. Find the median marks from the following data:

<b>Marks</b>	Below 10	Below 20	Below 30	Below 40	Below 50
<b>Number of students</b>	15	45	90	102	120

9. The following is the cumulative frequency distribution (of less than type) of 1000 persons each of age 20 years and above. Determine the median age.

<b>Age Below(in years)</b>	30	40	50	60	70	80
<b>No. of persons</b>	100	220	350	750	950	1000

10. Find the median age from the following distribution :

<b>Age(in years)</b>	25-29	30-34	35-39	40-44	45-49	50-54	55-59
<b>No. of persons</b>	4	14	22	16	6	5	3

11. Find the median marks for the following distribution:

<b>Marks</b>	Below 10	Below 20	Below 30	Below 40	Below 50	Below 60
<b>No. of Students</b>	6	15	29	41	60	70

12. Find the median marks for the following distribution:

<b>Marks below</b>	10	20	30	40	50	60	70	80
<b>No. of Students</b>	12	32	57	80	92	116	164	200

13. Find the median wages for the following frequency distribution:

<b>Wages per day</b>	61-70	71-80	81-90	91-100	101-110	111-120
<b>No. of workers</b>	5	15	20	30	10	8

14. Find the median marks for the following distribution:

<b>Marks</b>	11-15	16-20	21-25	26-30	31-35	36-40	41-45	46-50
<b>No. of Students</b>	2	3	6	7	14	12	4	2

15. Find the median age of the patients from the following distribution :

<b>Age(in years)</b>	5-14	15-24	25-34	35-44	45-54	55-64
<b>No. of patients</b>	6	11	21	23	14	5

.....



**PRACTICE QUESTIONS**  
**CLASS X: CHAPTER - 14**  
**STATISTICS**  
**MODE BASED QUESTIONS**

1. Will the median class and modal class of grouped data always be different? Justify your answer.
2. The frequency distribution table of agriculture holdings in a village is given below:

<b>Area of land(in ha)</b>	1-3	3-5	5-7	7-9	9-11	11-13
<b>No. of families</b>	20	45	80	55	40	12

Find the modal agriculture holdings of the village.

3. The weight of coffee in 70 packets is shown below:

<b>Weight (in gm):</b>	200-201	201-202	202-203	203-204	204-205	205-206
<b>No. of packets:</b>	12	26	20	9	2	1

Determine the modal weight.

4. Find the mode marks from the following data:

<b>Marks</b>	Below 10	Below 20	Below 30	Below 40	Below 50
<b>Number of students</b>	15	45	90	102	120

5. Find the mode of the following frequency distribution:

<b>Marks</b>	10 – 20	20 – 30	30 – 40	40 – 50	50 – 60
<b>Number of students</b>	15	30	45	12	18

6. Find the mode of the following frequency distribution:

<b>Marks</b>	Less than 20	Less than 40	Less than 60	Less than 80	Less than 100
<b>Number of students</b>	4	10	28	36	50

7. The following table show the marks of 85 students of a class X in a school. Find the modal marks of the distribution:

<b>Marks(Below)</b>	10	20	30	40	50	60	70	80	90	100
<b>Number of Students</b>	5	9	17	29	45	60	70	78	83	85

8. Find the mode of the following frequency distribution:

<b>Class</b>	25-30	30-35	35-40	40-45	45-50	50-55
<b>Frequency</b>	25	34	50	42	38	14

9. Find the average height of maximum number of students from the following distribution:

<b>Height(in cm)</b>	160-162	163-165	166-168	169-171	172-174
<b>No. of students</b>	15	118	142	127	18

10. Compare the modal ages of two groups of students appearing for an entrance examination:

<b>Age(in years)</b>	16-18	18-20	20-22	22-24	24-26
<b>Group A</b>	50	78	46	28	23
<b>Group B</b>	54	89	40	25	17

11. Find the mode age of the patients from the following distribution :

<b>Age(in years)</b>	6-15	16-25	26-35	36-45	46-55	56-65
<b>No. of patients</b>	6	11	21	23	14	5

12. 100 surnames were randomly picked up from a local telephone directory and the frequency distribution of the number of letters in the English alphabets in the surnames was obtained as follows:

<b>Number of letters</b>	1 - 4	4 - 7	7 - 10	10 - 13	13 - 16	16 - 19
<b>Number of surnames</b>	6	30	40	16	4	4

Determine the median number of letters in the surnames. Find the mean number of letters in the surnames? Also, find the modal size of the surnames.

13. Find the mean, mode and median for the following frequency distribution.

<b>Class</b>	0-10	10-20	20-30	30-40	40-50	Total
<b>Frequency</b>	8	16	36	34	6	100

14. A survey regarding the heights (in cms) of 50 girls of a class was conducted and the following data was obtained.

<b>Height(in cm)</b>	120-130	130-140	140-150	150-160	160-170	<b>Total</b>
<b>No. of girls</b>	2	8	12	20	8	<b>50</b>

Find the mean, median and mode of the above data.

15. Find the mean, mode and median marks for the following frequency distribution.

<b>Marks</b>	Less than 10	Less than 20	Less than 30	Less than 40	Less than 50	Less than 60
<b>No. of Students</b>	2	3	6	7	14	20

16. Find the mean, mode and median for the following frequency distribution.

<b>Class</b>	25-29	30-34	35-39	40-44	45-49	50-54	55-59
<b>Frequency</b>	14	22	16	6	5	3	4

17. Find the mean, mode and median for the following frequency distribution.

<b>Class</b>	0-10	10-20	20-30	30-40	40-50	50-60	60-70
<b>Frequency</b>	5	10	18	30	20	12	5

18. Find the mean, mode and median for the following frequency distribution.

<b>Class</b>	15-19	20-24	25-29	30-34	35-39	40-44	45-49
<b>Frequency</b>	3	13	21	15	5	4	2

19. Find the mean, mode and median for the following frequency distribution.

<b>Class</b>	500-520	520-540	540-560	560-580	580-600	600-620
<b>Frequency</b>	14	9	5	4	3	5

20. Find the mean, mode and median age in years for the following frequency distribution.

Age in years	10 – 19	20 – 29	30 – 39	40 – 49	50 – 59	60 – 69
No. of persons	8	8	10	14	28	32



**PRACTICE QUESTIONS**  
**CLASS X: CHAPTER - 14**  
**STATISTICS**  
**MISSING FREQUENCY BASED QUESTIONS**

1. The mean of the following distribution is 18. The frequency  $f$  in the class interval 19-21 is missing. Determine  $f$ .

<b>Class</b>	11-13	13-15	15-17	17-19	19-21	21-23	23-25
<b>Frequency</b>	3	6	9	13	$f$	5	4

2. The mean of the following distribution is 24. Find the value of  $p$ .

<b>Marks</b>	0-10	10-20	20-30	30-40	40-50	50-60
<b>No. of Students</b>	15	20	35	$P$	10	42

3. Find the missing frequencies  $f_1$  and  $f_2$  in table given below; it is being given that the mean of the given frequency distribution is 50.

<b>Class</b>	0-20	20-40	40-60	60-80	80-100	Total
<b>Frequency</b>	17	$f_1$	32	$f_2$	19	120

4. Find the missing frequencies  $f_1$  and  $f_2$  in table given below; it is being given that the mean of the given frequency distribution is 145.

<b>Class</b>	100-120	120-140	140-160	160-180	180-200	<b>Total</b>
<b>Frequency</b>	10	$f_1$	$f_2$	15	5	<b>80</b>

5. The mean of the following frequency distribution is 57.6 and the sum of the observations is 50. Find  $f_1$  and  $f_2$ .

<b>Class</b>	0-20	20-40	40-60	60-80	80-100	100-120
<b>Frequency</b>	7	$f_1$	12	$f_2$	8	5

6. The mean of the following frequency distribution is 28 and the sum of the observations is 100. Find  $f_1$  and  $f_2$ .

<b>Marks</b>	0-10	10-20	20-30	30-40	40-50	50-60
<b>No. of Students</b>	12	18	$f_1$	20	$f_2$	6

7. The mean of the following frequency distribution is 53. But the frequencies  $a$  and  $b$  in the classes 20-40 and 60-80 are missing. Find the missing frequencies.

<b>Age (in years)</b>	0 - 20	20 - 40	40 - 60	60 - 80	80 - 100	Total
<b>Number of people</b>	15	$a$	21	$b$	17	100

8. Compute the missing frequencies  $x$  and  $y$  in the following data if the mean is  $166\frac{9}{26}$  and the sum of the frequencies is 52:

<b>Class Interval</b>	140 – 150	150 – 160	160 – 170	170 – 180	180 – 190	190 – 200
<b>Frequency</b>	5	$x$	20	$y$	6	2

9. If the median of the distribution given below is 28.5, find the values of  $x$  and  $y$ .

<b>C. I.</b>	0 - 10	10 - 20	20 - 30	30 - 40	40 - 50	50 - 60
<b>F</b>	5	$x$	20	15	$y$	5

10. The median of the following data is 525. Find the values of  $x$  and  $y$ , if the total frequency is 100.

<b>C.I</b>	0-100	100-200	200-300	300-400	400-500	500-600	600-700	700-800	800-900	900-1000
<b>F</b>	2	5	$x$	12	17	20	$y$	9	7	4

11. The median of the following data is 28. Find the values of  $x$  and  $y$ , if the total frequency is 50.

<b>Marks</b>	0-7	7-14	14-21	21-28	28-35	35-42	42-49
<b>No. of Students</b>	3	$x$	7	11	$y$	16	9

12. Find the missing frequencies in the following frequency distribution table, if the total frequency is 100 and median is 32.

<b>Marks</b>	0-10	10-20	20-30	30-40	40-50	50-60
<b>No. of Students</b>	10	$x$	25	30	$y$	10

13. Find the missing frequencies in the following frequency distribution table, if the total frequency is 70 and median is 35.

<b>Marks</b>	0-10	10-20	20-30	30-40	40-50	50-60
<b>No. of Students</b>	6	9	$x$	$y$	19	10

14. The median of the following data is 167. Find the values of  $x$ .

<b>Height(in cm)</b>	160-162	163-165	166-168	169-171	172-174
<b>Frequency</b>	15	117	$x$	118	14

15. The mode of the following data is 36. Find the values of  $x$ .

<b>Class</b>	0-10	10-20	20-30	30-40	40-50	50-60	60-70
<b>Frequency</b>	8	10	$x$	16	12	6	7

16. Find the missing frequencies in the following frequency distribution table, if the total frequency is 100 and mode is  $46\frac{2}{3}$ .

<b>Class</b>	0-10	10-20	20-30	30-40	40-50	50-60	60-70	70-80
<b>Frequency</b>	5	8	7	$x$	28	20	10	$y$

.....

**PRACTICE QUESTIONS**  
**CLASS X: CHAPTER - 14**  
**STATISTICS**  
**OGIVE BASED QUESTIONS**

- Is it correct to say that an ogive is a graphical representation of a frequency distribution? Give reason.
- Which measure of central tendency is given by the  $x$  – coordinate of the point of intersection of the more than ogive and less than ogive?
- The following is the distribution of weights (in kg) of 40 persons:

<b>Weight(in kg)</b>	40-45	45-50	50-55	55-60	60-65	65-70	70-75	75-80
<b>No. of persons</b>	4	4	13	5	6	5	2	1

Construct a cumulative frequency distribution (of less than type) table for the data above.

- Find the unknown entries a, b, c, d, e, f in the following distribution of heights of students in a class:

<b>Height(in cm)</b>	150-155	155-160	160-165	165-170	170-175	175-180
<b>Frequency</b>	12	b	10	d	e	2
<b>Cumulative Frequency</b>	a	25	c	43	48	f

- Following is the age distribution of a group of students. Draw the cumulative frequency curve less than type and hence obtain the median from the graph.

<b>Age(in years)</b>	4-5	5-6	6-7	7-8	8-9	9-10	10-11	11-12	12-13	13-14	14-15	15-16
<b>No. of students</b>	36	42	52	60	68	84	96	82	66	48	50	16

- For the following distribution, draw the cumulative frequency curve more than type and hence obtain the median from the graph.

<b>Class</b>	0-10	10-20	20-30	30-40	40-50	50-60	60-70
<b>Frequency</b>	5	15	20	23	17	11	9

- Draw less than ogive for the following frequency distribution:

<b>Marks</b>	0 – 10	10 – 20	20 – 30	30 – 40	40 – 50	50 – 60
<b>Number of students</b>	5	8	6	10	6	6

Also find the median from the graph and verify that by using the formula.

- The table given below shows the frequency distribution of the cores obtained by 200 candidates in a BCA examination.

<b>Score</b>	200-250	250-300	300-350	350-400	400-450	450-500	500-550	550-600
<b>No. of students</b>	30	15	45	20	25	40	10	15

Draw cumulative frequency curves by using (i) less than type and (ii) more than type. Hence find median

- Draw less than and more than ogive for the following frequency distribution:

<b>Marks</b>	0 – 10	10 – 20	20 – 30	30 – 40	40 – 50	50 – 60
<b>Number of students</b>	8	5	10	6	6	6

Also find the median from the graph and verify that by using the formula.

10. The following table gives production yield per hectare of wheat of 100 farms of a village.

<b>production yield (in kg/ha)</b>	50 - 55	55 - 60	60 - 65	65 - 70	70 - 75	75 - 80
<b>Number of farms</b>	2	8	12	24	38	16

Change the distribution to a more than type distribution, and draw its ogive.

11. The following table gives the heights (in meters) of 360 trees:

<b>Height (in m)</b>	Less than 7	Less than 14	Less than 21	Less than 28	Less than 35	Less than 42	Less than 49	Less than 56
<b>No. of trees</b>	25	45	95	140	235	275	320	360

From the above data, draw an ogive and find the median

12. From the following data, draw the two types of cumulative frequency curves and determine the median from the graph.

<b>Height(in cm)</b>	<b>Frequency</b>
140-144	3
144-148	9
148-152	24
152-156	31
156-160	42
160-164	64
164-168	75
168-172	82
172-176	86
176-180	34

13. For the following distribution, draw the cumulative frequency curve more than type and hence obtain the median from the graph.

<b>Marks</b>	Below 10	Below 20	Below 30	Below 40	Below 50	Below 60
<b>No. of Students</b>	6	15	29	41	60	70

14. For the following distribution, draw the cumulative frequency curve less than type and hence obtain the median from the graph.

<b>Age equal and above(in years)</b>	0	10	20	30	40	50	60	70
<b>No. of Persons</b>	100	90	75	50	25	15	5	0

15. During the medical check-up of 35 students of a class, their weights were recorded as follows: Draw a less than type ogive for the given data. Hence obtain the median weight from the graph and verify the result by using the formula.

<b>Weight (in kg)</b>	Less than 38	Less than 40	Less than 42	Less than 44	Less than 46	Less than 48	Less than 50	Less than 52
<b>No. of students</b>	0	3	5	9	14	28	32	35

