

# SCIENCE

## ***REFERENCE STUDY MATERIAL***

*for*

**CLASS – X (TERM-II)**

**CHAPTER WISE CONCEPTS, FORMULAS AND  
QUESTIONS INCLUDING MCQs, HOTS  
QUESTIONS**

Prepared by

***M. S. KUMARSWAMY, TGT(MATHS)***  
***M. Sc. Gold Medallist (Elect.), B. Ed.***

**Kendriya Vidyalaya gachibowli**

ISAMPAL  
DEPUTY COMMISSIONER



केन्द्रीय विद्यालय संगठन, क्षेत्रीय कार्यालय,  
के. कामराज मार्ग, बेंगलूर-560 042

KENDRIYA VIDYALAYA SANGATHAN  
REGIONAL OFFICE

K. KAMARAJA ROAD, BANGALORE- 560042

**F. DO-DC./2013-KVS(BGR)**

**Dated:05.09.2013**

**Dear Shri M.S.Kumarswamy,**

It has been brought to my notice the good work done by you with regard to making question bank and worksheets for classes VI to X in Mathematics. I am pleased to look at your good work. Mathematics is one discipline which unfortunately and wrongly perceived as a phobia. May be lack of motivation from teachers and inadequate study habits of students is responsible for this state of affairs. Your work in this regard assumes a great significance. I hope your own students as well as students of other Vidyalayas will benefit by your venture. You may mail the material to all the Kendriya Vidyalayas of the region for their benefit. Keep up the good work.

**May God bless!,**

**Yours sincerely,**

**(Isampal)**

Shri M.S.Kumarswamy  
TGT (Maths)  
Kendriya Vidyalaya  
Donimalai

Copy to: the principals, Kendriya Vidyalayas, Bangalore Region with instructions to make use of the materials prepared by Mr. M.S.Kumarswamy being forwarded separately.

**DEDICATED  
TO  
MY FATHER**

**LATE SHRI. M. S. MALLAYYA**

## CHAPTER – 4

### CARBON AND ITS COMPOUND

#### CARBON: INTRODUCTION

Carbon is the fourth most abundant element in the universe by mass. It is also the second most abundant element in the human body after oxygen. It is the 15th most common element in the Earth's crust. Carbon was discovered in prehistory and it was known to the ancients. They used to manufacture charcoal by burning organic material.

**Carbon** is a non-metal. It belongs to the fourteenth group or IV A group in the modern periodical table. The elements of this group have four electrons in the valence shell.

Atomic Number: 6

Electronic configuration: 2, 4

Valence electrons: 4

Property: Non-metal

Compounds having carbon atoms among the components are known as carbon compounds. Previously, carbon compounds could only be obtained from a living source; hence they are also known as organic compounds.

#### BONDING IN CARBON: COVALENT BOND

Bond formed by sharing of electrons is called covalent bond. Two or more atoms share electrons to make their configuration stable. In this type of bond, all the atoms have similar rights over shared electrons. Compounds which are formed because of covalent bond are called COVALENT COMPOUNDS.

#### FORMATION OF COVALENT BONDS

1. **Covalent bond** is the chemical bond formed through the **sharing of electrons between two non-metal atoms**.
2. Compounds which have covalent bonds are called **covalent compounds**.
3. Examples of covalent compounds or molecules are chlorine,  $\text{Cl}_2$ , carbon dioxide,  $\text{CO}_2$ , ammonia,  $\text{NH}_3$ , water,  $\text{H}_2\text{O}$ , and tetrachloromethane (carbon tetrachloride),  $\text{CCl}_4$ .
4. During the formation of covalent molecules, **each non-metal covalent atom** provides one, two or three electrons to be **shared** with other atoms. The bond formed is called a covalent bond.
5. Through this process, each non-metal atom in covalent molecules will achieve **stable electron arrangement**.
6. The type of covalent bond formed in a covalent compound depends on the number of electron pairs shared between non-metal atoms.

Covalent bonds are of three types: Single, double and triple covalent bond.

#### SINGLE COVALENT BOND

1. A single covalent bond is the covalent bond formed through the **sharing of a pair of electrons between two non-metal atoms**.

- Each non-metal atom contributes one electron for sharing to achieve a **stable electron arrangement**.
- Example of single covalent compound are chlorine gas,  $\text{Cl}_2$ , hydrogen chloride,  $\text{HCl}$ , water,  $\text{H}_2\text{O}$ , methane,  $\text{CH}_4$ , ammonia,  $\text{NH}_3$ , and tetrachloromethane,  $\text{CCl}_4$ .
- Single covalent bonds can also be formed between different non-metal atoms.

### Formation of hydrogen molecule ( $\text{H}_2$ )

Atomic Number of  $\text{H} = 1$

Electronic configuration of  $\text{H} = 1$

Valence electron of  $\text{H} = 1$

Hydrogen forms a duet, to obtain stable configuration. This configuration is similar to helium (a noble gas).

Since, hydrogen has one electron in its valence shell, so it requires one more electron to form a duet. So, in the formation of hydrogen molecule; one electron from each of the hydrogen atoms is shared.

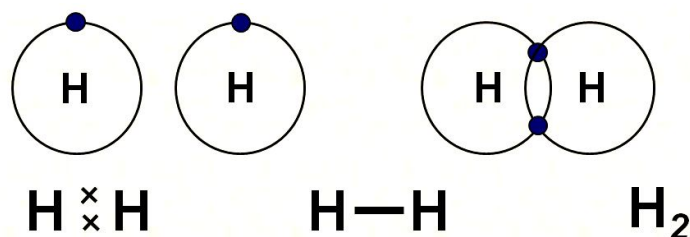

### Formation of hydrogen chloride ( $\text{HCl}$ ):

Valence electron of hydrogen = 1

Atomic number of chlorine = 17

Electronic configuration of chlorine: 2, 8, 7

Electrons in outermost orbit = 7

Valence electron = 7

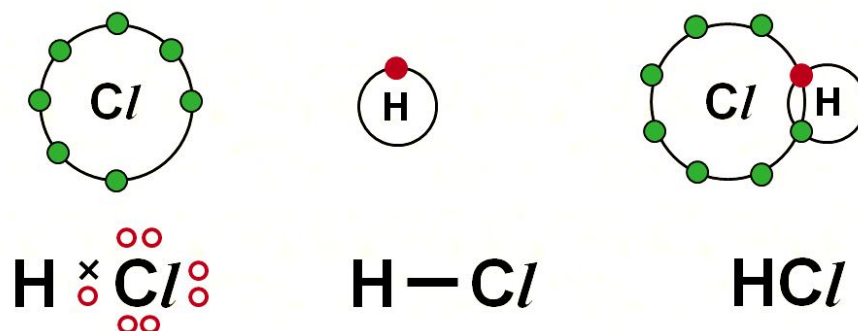

### Formation of chlorine molecule ( $\text{Cl}_2$ ):

Valence electron of chlorine = 7

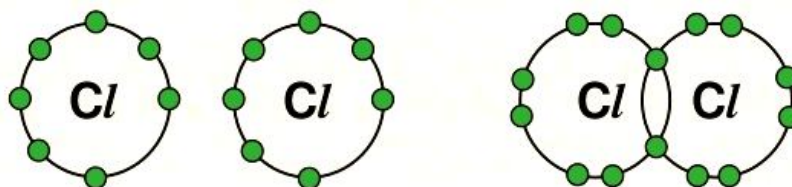

### Formation of water ( $\text{H}_2\text{O}$ )

Valence electron of hydrogen = 1

Atomic number of oxygen = 8

Electronic configuration of oxygen = 2, 6

Valence electron = 6

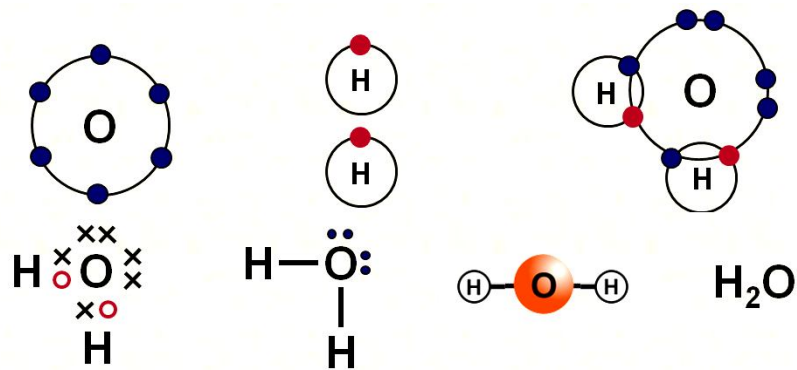

### Formation of Methane (CH<sub>4</sub>)

Valence electron of carbon = 4

Valence electron of hydrogen = 1

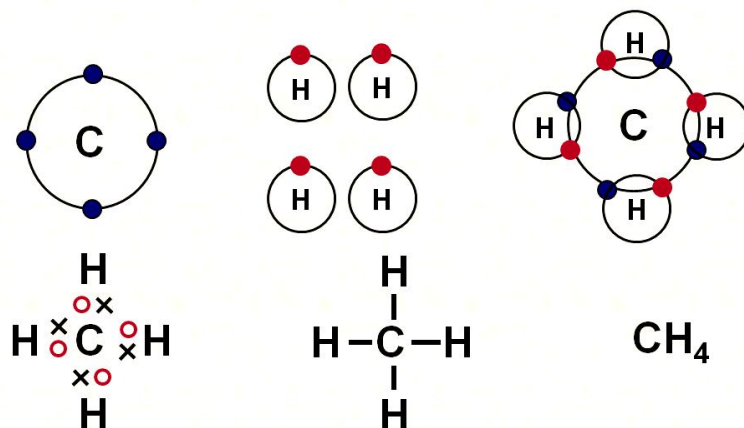

### DOUBLE COVALENT BOND

1. Double covalent bond is the type of covalent bond formed through the **sharing of two pairs of electrons between two non-metal atoms.**
2. Examples of molecules which have double covalent bonds are oxygen, O<sub>2</sub>, and carbon dioxide, CO<sub>2</sub>.
3. During the formation of double bond, each **non-metal atom contributes two pairs of electrons to be shared** to achieve a **stable electron arrangement.**

### Formation of oxygen molecule (O<sub>2</sub>):

Valence electron of oxygen = 2

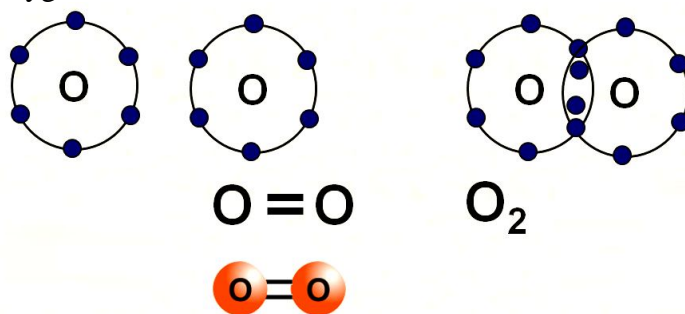

- In the formation of oxygen molecule, two electrons are shared by each of the two oxygen atoms to complete their stable configuration.
- In oxygen, the total number of shared electrons is four, two from each of the oxygen atoms. So a double covalent bond is formed.

### Formation of Carbon dioxide (CO<sub>2</sub>):

Valence electron of carbon = 4

Valence electron of oxygen = 6

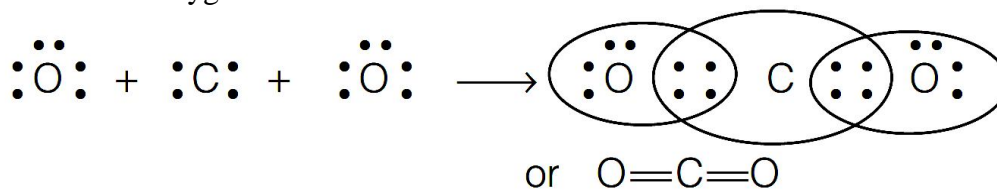

In carbon dioxide two double covalent bonds are formed.

### Formation of Ethylene (C<sub>2</sub>H<sub>4</sub>):

Valence electron of carbon = 4

Valence electron of hydrogen = 1

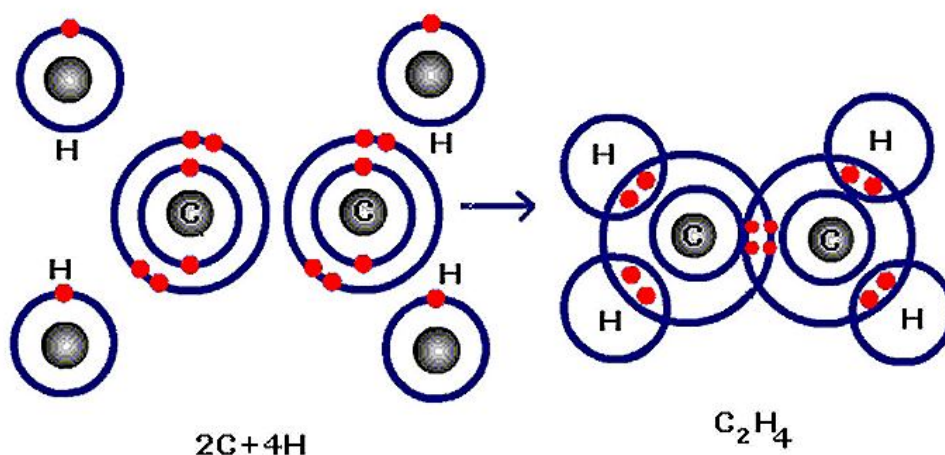

### TRIPLE COVALENT BOND

1. The triple covalent bond is the type of covalent bond formed through the **sharing of three pairs of electrons between two non-metal atoms.**
2. Example of molecule which has triple covalent bonds is the nitrogen molecule, N<sub>2</sub>.

### Formation of Nitrogen (N<sub>2</sub>):

Atomic number of nitrogen = 7

Electronic configuration of nitrogen = 2, 5

Valence electron = 5

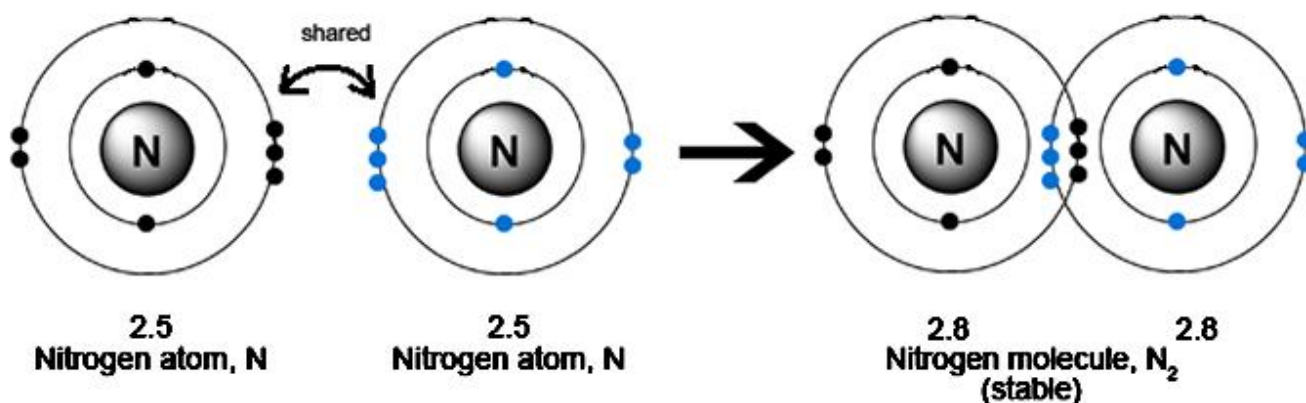

In the formation of nitrogen, three electrons are shared by each of the nitrogen atoms. Thus one triple bond is formed because of the sharing of total six electrons.

### Properties of Covalent Bond:

- Intermolecular force is smaller.
- Covalent bonds are weaker than ionic bond. As a result, covalent compounds have low melting and boiling points.
- Covalent compounds are poor conductor of electricity as no charged particles are formed in covalent bond.
- Since, carbon compounds are formed by the formation of covalent bond, so carbon compounds generally have low melting and boiling points and are poor conductor of electricity.

### ALLOTROPY

Allotropy is defined as the property by which an element can exist in more than one form that are physically different but chemically similar.

### Allotropes of carbon

Carbon exists in three allotropic forms. They are crystalline form (diamond and graphite), amorphous form (coke, charcoal) and fullerene.

In diamond each carbon atom is bonded to four other carbon atoms forming a rigid three dimensional structure, accounting for its hardness and rigidity.

### General properties of diamond are

- ☞ It is a colourless transparent substance with extraordinary brilliance due to its high refractive index.
- ☞ It is quite heavy.
- ☞ It is extremely hard (hardest natural substance known).
- ☞ It does not conduct electricity (because of the absence of free electrons).
- ☞ It has high thermal conductivity and high melting point.
- ☞ It burns on strong heating to form carbon dioxide.

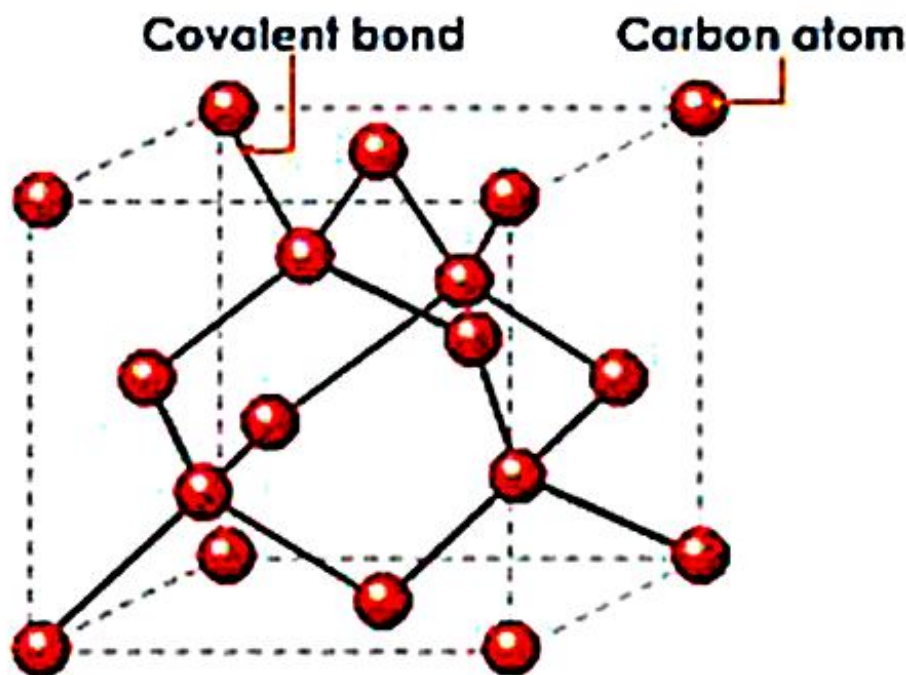

In graphite each carbon atom is bonded to three other carbon atoms in the same plane giving hexagonal layers held together by weak **vander Waals forces** accounting for softness.



### General properties of graphite are

- ☞ It is a greyish black opaque substance.
- ☞ It is lighter than diamond, feels soft and slippery to touch.
- ☞ It is a good conductor of electricity (due to the presence of free electrons) but bad conductor of heat.
- ☞ It burns on strong heating to form carbon dioxide.

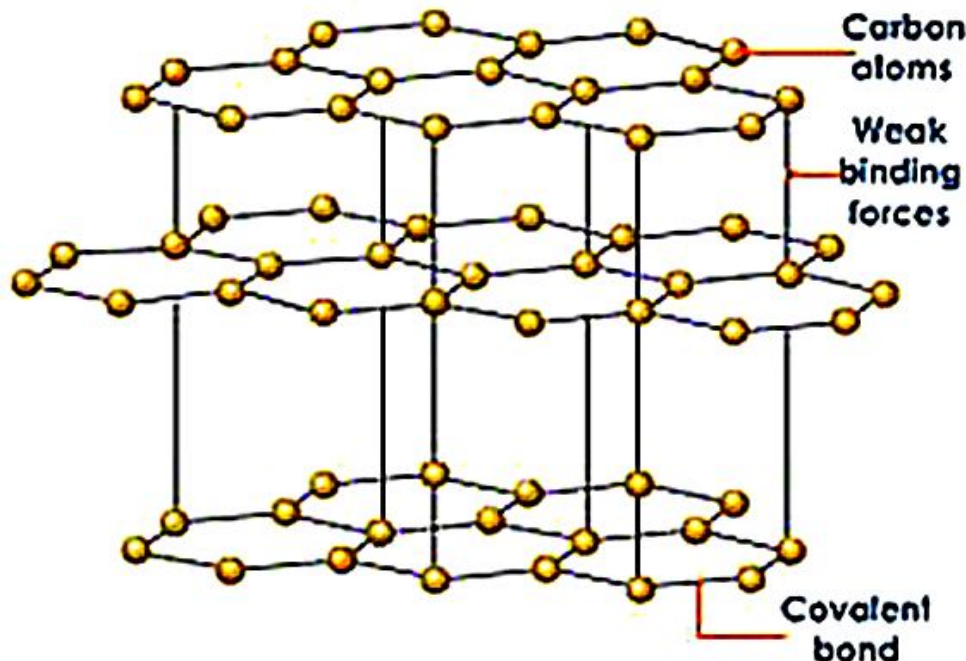

Fullerenes form another type of carbon allotropes. The first one was identified to contain 60 carbon atoms in the shape of a football. (C-60). Since this looks like the geodesic dome designed by the US architect Buckminster Fuller, it is named as Buckminster Fullerene.

### General Properties of fullerenes are

- ☞ These are dark solids at room temperature.
- ☞ These are neither too hard nor too soft.
- ☞ These are the purest allotropic forms of carbon because of the absence of free valencies or surface bonds.
- ☞ On burning, these produce only carbon dioxide gas.

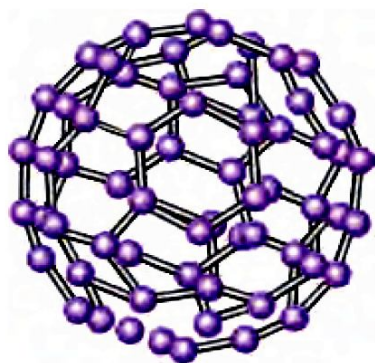

*Fullerene*



*Foot ball*

## VERSATILE NATURE OF CARBON

Initially, compounds of carbon could only be obtained from living sources and there was no way of synthesizing them. Hence, carbon compounds are also known as organic compounds. Carbon forms a large number of compounds. So far, formulae of about 3 million carbon compounds are known.

Cause of formation of such a large number of compounds by carbon:

- ☞ Carbon can form bonds with other carbon atoms. This property of carbon is known as **CATENATION**. Because of catenation, carbon can form a long chain; while making bond with other carbon atoms. Carbon can make single, double and triple bonds by catenation.
- ☞ Carbon can form branched chain; along with straight chain; while combining with carbon atoms, i.e. because of the property of catenation.
- ☞ Due to the valency of four, carbon is capable of bonding or pairing with four other carbon atoms or with the atoms of some other monovalent elements. It also forms compounds with oxygen, nitrogen, sulphur, hydrogen and many other elements. This gives rise to compounds with specific properties which depend on the element other than carbon present in the molecule.
- ☞ Bonds which carbon forms with other elements are very strong thus, making these compounds very stable. The main reason for such strong bond formation is the small size of carbon. As a result, the shared pair of electrons are tightly held by the nucleus.

## ORGANIC COMPOUNDS

The compounds of carbon except its oxides, carbonates and hydrogen carbonate salts, are known as **organic compounds**. These compounds were initially extracted from natural substances and was believed that some vital force was necessary for the synthesis of these compounds (vital force theory).

## HYDROCARBONS

(Hydrogen + Carbon = Hydrocarbon) Compounds formed because of the combination of hydrogen and carbon are known as hydrocarbons. These are regarded as the **parent organic compounds** and all other compounds are considered to be derived from them by the replacement of one or more hydrogen atoms by other atoms or groups of atoms.

Hydrocarbons can be divided into various classes as shown in below:

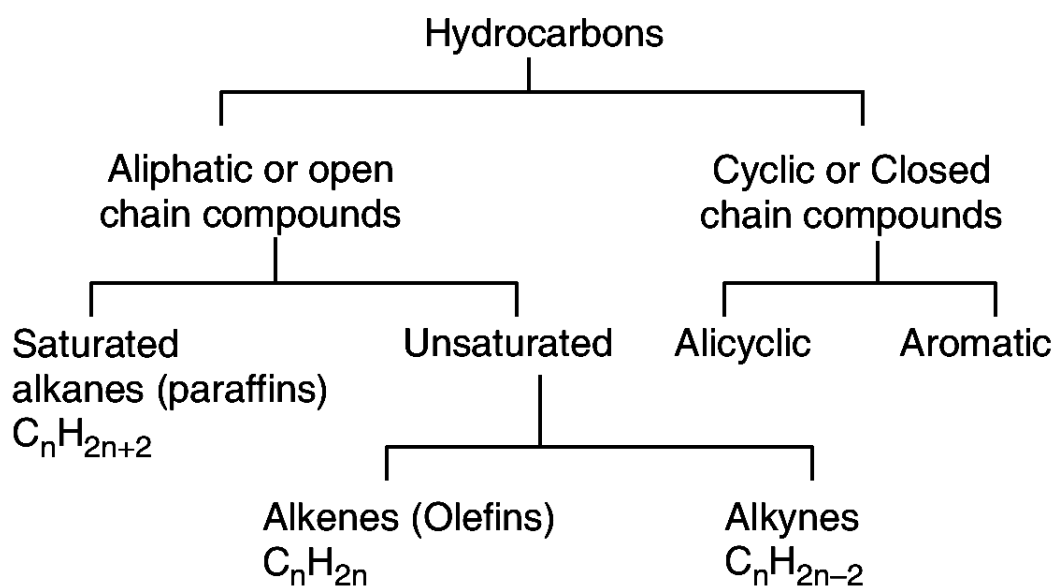

## ALIPHATIC HYDROCARBONS

The word aliphatic is derived from the Greek word aleiphar meaning fat. Aliphatic hydrocarbons were named so because they were derived from fats and oils. Hydrocarbons can be *acyclic* compounds, which are straight chain compounds, or cyclic compounds, which have rings of carbon atoms.

## AROMATIC HYDROCARBONS

The word aromatic is derived from the word *aroma* meaning fragrance. The aromatic compounds have a characteristic smell. Structurally, they include benzene and its derivative.

The *aliphatic hydrocarbons* can be divided into two categories: **saturated hydrocarbons** and **unsaturated hydrocarbons**. In *saturated hydrocarbons*, carbon atoms are linked to each other by single bonds whereas in *unsaturated hydrocarbons*, multiple bond (double and triple bonds) are present between carbon atoms.

## SATURATED HYDROCARBONS

### Alkanes

**General formula =  $C_nH_{2n+2}$  Suffix : ane**

These are the organic compounds which contain carbon – carbon single bond. These were earlier named as **paraffins**(Latin : meaning little affinity) due to their least chemical reactivity. According to IUPAC system, these are named as **alkanes** (ane is suffix with root word).

## UNSATURATED HYDROCARBONS

These are hydrocarbons which contain carbon to carbon double bonds or carbon to carbon triple bonds in their molecules. These are further classified into two types: **alkenes and alkynes**.

i) **Alkenes: General formula:  $C_nH_{2n}$  Suffix : ene**

The hydrocarbons containing atleast one carbon to carbon double bond are called **alkenes**. They have the general formula  $C_nH_{2n}$ . These were previously called **olefins** (Greek : olefiant – oil forming) because the lower gaseous members of the family form oily products when treated with chlorine.

In IUPAC system, the name of alkene is derived by replacing suffix “**ane**” of the corresponding alkane by “**ene**”. For example,

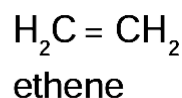
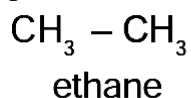

In higher alkenes, the position of the double bond, can be indicated by assigning numbers 1, 2, 3, 4, .....to the carbon atoms present in the molecule.

Alkene	Common name	IUPAC name
$\text{CH}_2 = \text{CH}_2$	Ethylene	Ethene
$\text{CH}_3\text{CH} = \text{CH}_2$	Propylene	Propene
$\text{CH}_3\text{CH}_2 - \text{CH} = \text{CH}_2$	$\alpha$ -Butylene	But-1-ene
$\text{CH}_3\text{CH} = \text{CHCH}_3$	$\beta$ -Butylene	But-2-ene

ii) **Alkynes: General formula:  $C_nH_{2n-2}$       Suffix : yne**

The hydrocarbons containing carbon to carbon triple bond are called **alkynes**. Alkynes are named in the same way as alkenes i.e., by replacing suffix **ane** of alkane by **yne**. In higher members, the position of triple bond is indicated by giving numbers 1, 2, 3, 4, ....to the carbon atom in the molecule.

Alkyne	Common name	IUPAC name
$HC \equiv CH$	Acetylene	Ethyne
$H_3C - C \equiv CH$	Methyl acetylene	Propyne
$H_3C - C \equiv C - CH_3$	Dimethyl acetylene	But-2-yne
$H_3C - CH_2 - C \equiv CH$	Ethyl acetylene	But-1-yne

### **HOMOLOGOUS SERIES**

A homologous series is a group or a class of organic compounds having similar structure and similar chemical properties in which the successive compounds differ by a  $CH_2$  group.

#### **Characteristics of homologous series**

- ☞ Each member of the series differs from the preceding or succeeding member by a common difference of  $CH_2$  and by a molecular mass of 14 amu (amu = atomic mass unit).
- ☞ All members of homologous series contain same elements and the same functional groups.
- ☞ All members of homologous series have same general molecular formula.  
e.g      **Alkane** =  $C_nH_{2n+2}$   
            **Alkene** =  $C_nH_{2n}$   
            **Alkyne** =  $C_nH_{2n-2}$
- ☞ The members in homologous series show a regular gradation in their physical properties with respect to increase in molecular mass.
- ☞ The chemical properties of the members of the homologous series are similar.
- ☞ All members of homologous series can be prepared by using same general method.

#### **IMPORTANCE OF HOMOLOGOUS SERIES**

- ☞ It helps to predict the properties of the members of the series that are yet to be prepared.
- ☞ Knowledge of homologous series gives a systematic study of the members.
- ☞ The nature of any member of the family can be ascertained if the properties of the first member are known.

### **FUNCTIONAL GROUP**

**Functional group may be defined as an atom or group of atoms or reactive part which is responsible for the characteristic properties of the compounds.**

The chemical properties of organic compounds are determined by the functional groups while their physical properties are determined by the remaining part of the molecule.

### **CLASSIFICATION OF ORGANIC COMPOUNDS BASED ON FUNCTIONAL GROUP**

#### **1. ALCOHOLS**

Alcohols are carbon compounds containing  $\text{-OH}$  group attached to alkyl group. The general formula of alcohol is  $\text{R-OH}$  where ' $\text{R}$ ' is an **alkyl group** and  $\text{-OH}$  is the **functional group**. The IUPAC name of alcohol is derived by replacing  $\text{-e}$ , in the word **alkane**, by the suffix  $\text{-ol}$ . Hence we get the name **alkanol**.

Molecular formula	Common name	IUPAC name
$\text{CH}_3\text{OH}$	Methyl alcohol	Methanol
$\text{CH}_3\text{-CH}_2\text{-OH}$	Ethyl alcohol	Ethanol
$\text{CH}_3\text{-CH}_2\text{-CH}_2\text{-OH}$	n-Propyl alcohol	1-Propanol
$\begin{array}{c} \text{CH}_3\text{-CH-CH}_3 \\   \\ \text{OH} \end{array}$	Isopropyl alcohol or secondary propyl alcohol	2-Propanol
$\text{CH}_3\text{-CH}_2\text{-CH}_2\text{-CH}_2\text{-OH}$	n-Butyl alcohol	1-Butanol
$\begin{array}{c} \text{CH}_3\text{-CH-CH}_2\text{-OH} \\   \\ \text{CH}_3 \end{array}$	Isobutyl alcohol	2-Methyl-1-propanol

## 2. ALDEHYDES

Aldehydes are carbon compounds containing  $\text{-CHO}$  group attached to alkyl group or hydrogen atom. The general formula of aldehydes is  $\text{R-CHO}$  where ' $\text{R}$ ' is an **alkyl group** or **hydrogen atom** and  $\text{-CHO}$  is the **functional group**.

The IUPAC name of aldehyde is derived by replacing  $\text{-e}$ , in the word alkane, by the suffix  $\text{-al}$ . Hence we get the name "**alkanal**".

Molecular formula	Common name	IUPAC name
$\text{HCHO}$	Formaldehyde	Methanal
$\text{CH}_3\text{-CHO}$	Acetaldehyde	Ethanal
$\text{CH}_3\text{-CH}_2\text{-CHO}$	Propionaldehyde	Propanal
$\text{CH}_3\text{-CH}_2\text{-CH}_2\text{-CHO}$	Butyraldehyde	Butanal

## 3. KETONES

Ketones are carbon compounds containing carbonyl  $\text{-CO-}$  group attached to two alkyl groups. The general formula of ketone is  $\text{R-CO-R'}$  where  $\text{R}$  and  $\text{R'}$  are **alkyl groups** and  $\text{-CO-}$  is the **functional group**.

The IUPAC name of ketone is derived by replacing  $\text{-e}$ , in the word alkane, by the suffix  $\text{-one}$ . Hence we get the name "**alkanone**".

Molecular formula	Common name	IUPAC name
$\text{CH}_3\text{COCH}_3$	Dimethyl ketone (Acetone)	Propanone
$\text{CH}_3\text{COCH}_2\text{CH}_3$	Ethyl methyl ketone	Butanone
$\text{CH}_3\text{CH}_2\text{COCH}_2\text{CH}_3$	Diethyl ketone	3-Pentanone

#### 4. CARBOXYLIC ACIDS

Carboxylic acids are carbon compounds containing  $-\text{COOH}$  group attached to a hydrogen atom or alkyl group. The general formula of acid is  $\text{R-COOH}$  where 'R' is a **hydrogen atom** or **alkyl group** and  $-\text{COOH}$  is the **functional group**.

The IUPAC name of acid is derived by replacing -e, in the word alkane, by the suffix -oic acid. Hence we get the name "**alkanoic acid**".

Molecular formula	Common name	IUPAC name
$\text{HCOOH}$	Formic acid	Methanoic acid
$\text{CH}_3\text{-COOH}$	Acetic acid	Ethanoic acid
$\text{CH}_3\text{-CH}_2\text{-COOH}$	Propionic acid	Propanoic acid
$\text{CH}_3\text{-CH}_2\text{-CH}_2\text{-COOH}$	n-Butyric acid	Butanoic acid

#### ISOMERISM

Carbon compounds or organic compounds with same molecular formula can show different structures and hence, different properties. This phenomenon is called **isomerism** and compounds are called **isomers**.

For example, following two arrangements are possible for butane, an alkane with four C atoms ( $\text{C}_4\text{H}_{10}$ )

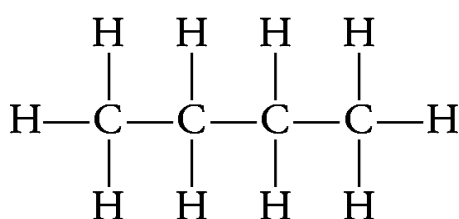

Straight chain structure

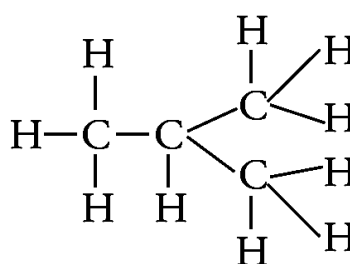

Branched chain structure

Such pair of isomers is called **chain isomers** and the isomerism is called **chain isomerism**. Thus, **chain isomers** are the compounds that have same molecular formula but differ in the arrangement of carbon chains.

## EXERCISE QUESTIONS PAGE NO. 77 and 78

**Q1. Ethane, with the molecular formula  $C_2H_6$  has**

- (a) 6 covalent bonds.
- (b) 7 covalent bonds.
- (c) 8 covalent bonds.
- (d) 9 covalent bonds.

**Ans:**

(b) Structure of  $C_2H_6$  is

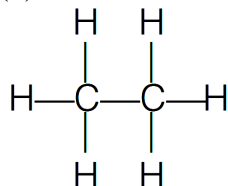

It is clear that it has 7 covalent bonds.

**Q2. Butanone is a four-carbon compound with the functional group**

- (a) carboxylic acid.
- (b) aldehyde.
- (c) ketone.
- (d) alcohol.

**Ans:** (c) In butanone, the function group is ketone (one)

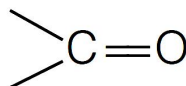

**Q3. While cooking, if the bottom of the vessel is getting blackened on the outside, it means that**

- (a) the food is not cooked completely.
- (b) the fuel is not burning completely.
- (c) the fuel is wet.
- (d) the fuel is burning completely.

**Ans:** (b) The unburnt particles of the fuel present in smoke blacken the vessel from outside.

**Q4. Explain the nature of the covalent bond using the bond formation in  $CH_3Cl$ .**

**Ans:**

Atomic number of

$C = 6$ ;  $H = 1$ ;  $Cl = 17$

Electronic configuration

	<i>K</i>	<i>L</i>		<i>K</i>	<i>L</i>	<i>M</i>		<i>K</i>	
	C	2	4	Cl	2	8	7	H	1

C needs 4 electrons to complete its octet, H needs 1 and Cl needs 1 electron.

$\therefore$  C shares its 4 electrons with each of the 3 H-atoms and 1 with chlorine atom. It thus forms 4 covalent bonds as shown.

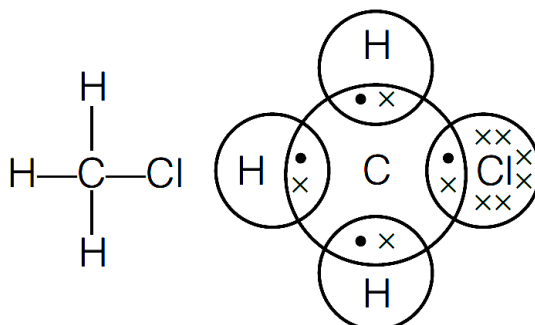

**Q5. Draw the electron dot structures for**

(a) ethanoic acid.

(b)  $\text{H}_2\text{S}$ .

(c) propanone.

(d)  $\text{F}_2$ .

**Ans:**

(a) ethanoic acid.

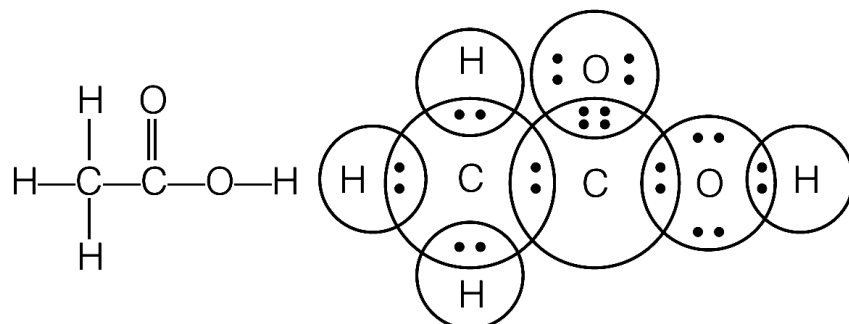

(b)  $\text{H}_2\text{S}$ .

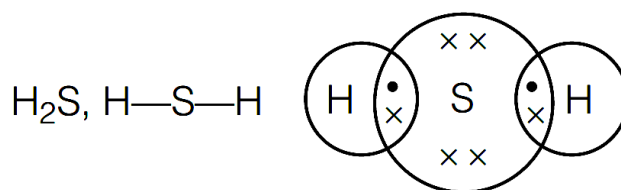

(c) propanone.

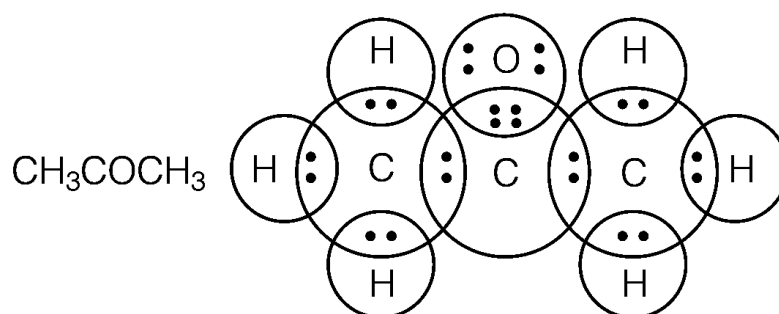

(d)  $\text{F}_2$ .

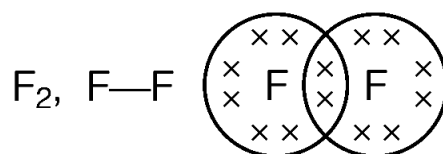

**Q6. What is an homologous series? Explain with an example.**

**Ans:**

A homologous series is a series of carbon compounds that have different numbers of carbon atoms but contain the same functional group.

Example of homologous series

Alkane series  $\text{C}_n\text{H}_{2n+2}$

$\text{CH}_4$  Methane,  $\text{C}_2\text{H}_6$  Ethane

$\text{C}_3\text{H}_8$  Propane,  $\text{C}_4\text{H}_{10}$  Butane  $\text{C}_5\text{H}_{12}$  Pentane

It can be noticed that there is a difference of  $-\text{CH}_2$  unit between each successive compound.

**Q7. How can ethanol and ethanoic acid be differentiated on the basis of their physical and chemical properties?**

**Ans:**



## I. Distinction based on physical properties

1. **Smell** Ethanoic acid has a pungent smell. Ethanol has a pleasant smell.
2. **Melting point** Ethanol has lower melting point (150 K) than ethanoic acid (290 K).
3. **Physical state** Ethanoic acid is solid (glacial acetic acid) in winters but ethanol is always a liquid.

## II. Distinction based on chemical properties

(i) **Action with sodium hydrogen carbonate** On adding a small amount of sodium hydrogen carbonate to ethanoic acid, carbon dioxide gas is evolved with brisk effervescence. However, no such reaction noticed in case of ethanol.

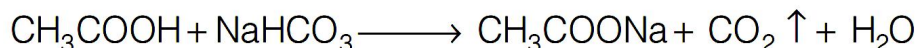

(ii) **Action with caustic alkalis** Ethanoic acids reacts with both sodium hydroxide (NaOH) and potassium hydroxide (KOH) to form corresponding salt and water. Ethanol fails to react with either of these.

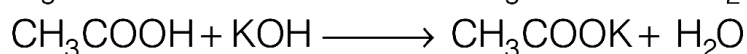
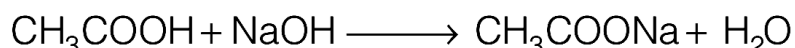

**Q8. Why does micelle formation take place when soap is added to water? Will a micelle be formed in other solvents such as ethanol also?**

**Ans:**

A soap is a sodium or potassium salt of long chain fatty acids. It has one polar end and one non-polar end. The polar end is hydrophilic in nature i.e., this end is attracted towards water. The non-polar end is hydrophobic but lipophilic, i.e., it is attracted towards hydrocarbons. When soap is added to water, soap molecules arrange themselves in a cluster to keep the non-polar portion out of water such that the non-polar ends are in the interior of the cluster and the polar ends are on the surface of the cluster. Since the dirt present on clothes is organic in nature and insoluble in water, the hydrophobic ends of the clusters attach themselves to the dirt. This cluster formation in which the dirt is entrapped is the micelle. Micelle formation does not occur in alcohol because the alkyl chain of soap becomes soluble in alcohol.

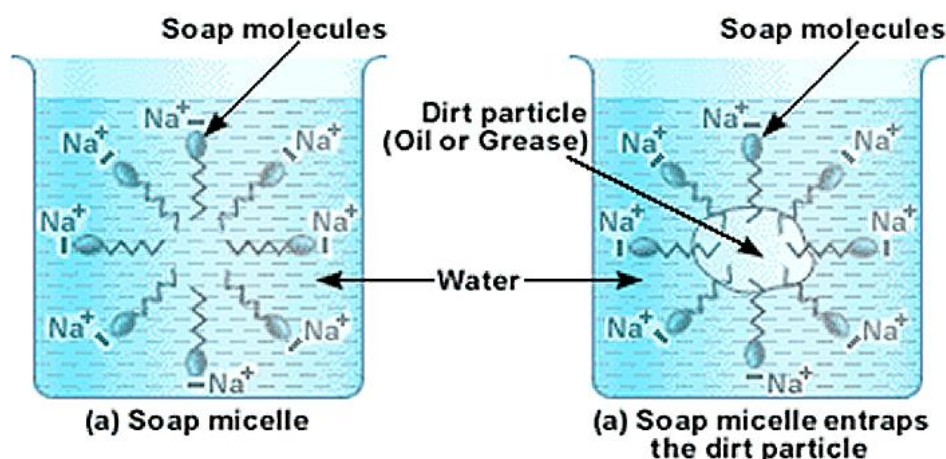

**Q9. Why are carbon and its compounds used as fuels for most applications?**

**Ans:**

Carbon burns in oxygen (air) to form carbon dioxide and water.

During this reaction a large amount of heat and light are released. Further, once ignited carbon and its compounds keep on burning without the requirement of additional energy. Hence, they are used as fuels.

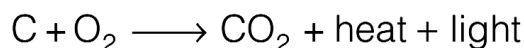

**Q10. Explain the formation of scum when hard water is treated with soap.****Ans:**

Soap does not work properly when the water is hard. A soap is a sodium or potassium salt of long chain fatty acids. Hard water contains salts of calcium and magnesium. When soap is added to hard water, calcium and magnesium ions present in water displace sodium or potassium ions from the soap molecules forming an insoluble substance called scum. A lot of soap is wasted in the process.

Reaction taking place are shown below.

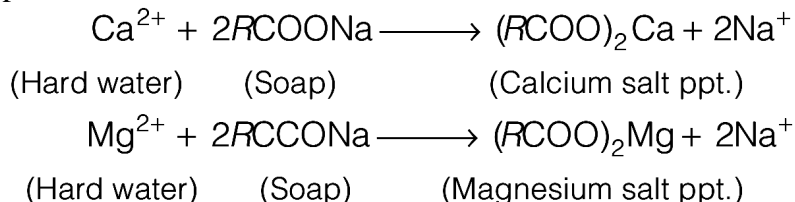
**Q11. What change will you observe if you test soap with litmus paper (red and blue)?****Ans:**

Since soap is basic in nature, it will turn red litmus blue. However, the colour of blue litmus will remain blue.

**Q12. What is hydrogenation? What is its industrial application?****Ans:**

Hydrogenation is the process of addition of hydrogen. Unsaturated hydrocarbons are added with hydrogen in the presence of palladium and nickel catalysts to give saturated hydrocarbons.

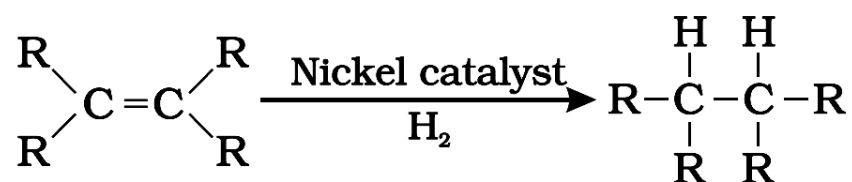

This reaction is applied in the hydrogenation of vegetables oils, which contain long chains of unsaturated carbons.

**Q13. Which of the following hydrocarbons undergo addition reactions:****C<sub>2</sub>H<sub>6</sub>, C<sub>3</sub>H<sub>8</sub>, C<sub>3</sub>H<sub>6</sub>, C<sub>2</sub>H<sub>2</sub> and CH<sub>4</sub>.****Ans:**

Unsaturated hydrocarbons containing double/ triple bond undergo addition reactions.

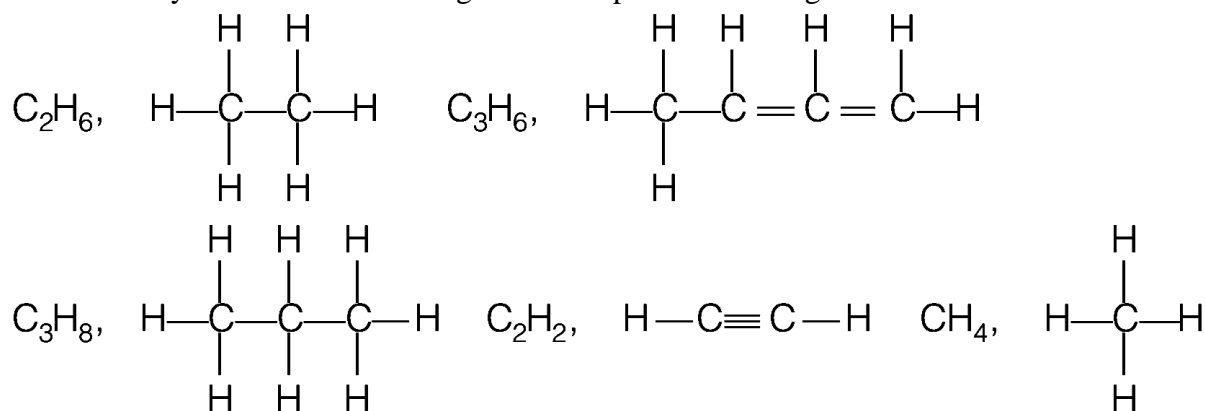

So, C<sub>3</sub>H<sub>6</sub> and C<sub>2</sub>H<sub>2</sub> will undergo addition reactions.

**Q14. Give a test that can be used to differentiate chemically between butter and cooking oil.**

**Ans:**

Butter contains saturated compounds while cooking oil contains unsaturated compounds. Since unsaturated compounds are oxidised by alkaline  $\text{KMnO}_4$  with disappearance of its pink colour.

$\therefore$  When cooking oil is treated with a few drops of alkaline  $\text{KMnO}_4$ , pink colour of  $\text{KMnO}_4$  disappears. With butter however, the pink colour  $\text{KMnO}_4$  does not disappear

**Q15. Explain the mechanism of the cleaning action of soaps.**

**Ans:**

**Cleansing action of soaps:**

The dirt present on clothes is organic in nature and insoluble in water. Therefore, it cannot be removed by only washing with water. When soap is dissolved in water, its hydrophobic ends attach themselves to the dirt and remove it from the cloth. Then, the molecules of soap arrange themselves in micelle formation and trap the dirt at the centre of the cluster. These micelles remain suspended in the water. Hence, the dust particles are easily rinsed away by water.

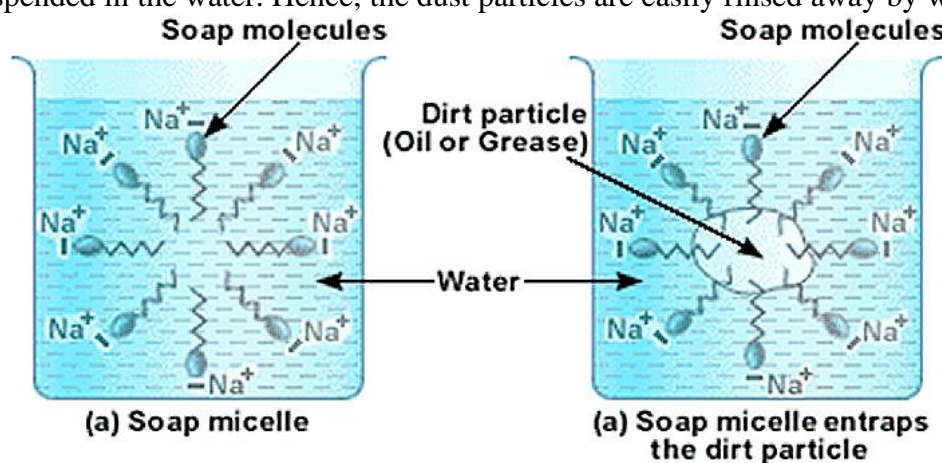

**ASSIGNMENT QUESTIONS SET – 1**  
**CHAPTER – 4**  
**CARBON AND ITS COMPOUND**

1. Which of the following is not a saturated hydrocarbon ?
  - i) Cyclohexane.
  - ii) Benzene.
  - iii) Butane
  - iv) isobutene
2. The bond between two identical non metallic atom has a pair of electron ?
  - i) un equally shared between two atoms.
  - ii) Transferred completely from one atom to another.
  - iii) With identical spins
  - iv) Unequally shared between them.
3. Covalent compounds are generally
  - i) Soluble in water
  - ii) Insoluble in water
  - iii) Ionize in water
  - iv) Hydrolyse in water
4. Propane with the molecular formula  $C_3H_8$  has
  - i) 7covalent bonds
  - ii) 8 covalent bonds
  - iii) 9 covalent bonds
  - iv) 10 Covalent bonds.
5. A hydrocarbon reacts with ammonical cuprous chloride solution to form a red precipitate .The hydrocarbon is
  - i)ethane
  - ii)ethene
  - iii)butane
  - iv)1-propyne
6. Which of the following substance is added to denature Ethanol ?
  - i)methanol
  - ii)pyridine
  - iii)copper sulphate
  - iv)all of them
7. Which of the following is not an allotropic form of carbon
  - i)fluorine
  - ii)fullerene
  - iii)diamond
  - iv)graphite

8. Which of the following represents the correct decreasing order of hydrogen atoms ?
- i) alkanes , alkenes , alkynes
  - ii) alkanes , alkynes , alkenes
  - iii) alkenes , alkynes , alkanes
  - iv) alkynes , alkanes , alkenes
9. Detergents are sodium or potassium salts of long chain of ;-
- i) aldehydes
  - ii) ketones
  - iii) carboxylic acid
  - iv) sulphonic acid
10. Which of the following represents the structure of  $N_2$  molecule ?
- i)  $N \equiv N$
  - ii)  $N = N$
  - iii)  $N - N$
  - iv) None of the above
11. In double covalent bond there is sharing of
- i) 2 electrons
  - ii) 4 electrons
  - iii) 6 electrons
  - iv) 3 electrons
12. Cation is formed when
- i) atom gains electrons
  - ii) atom loses electrons
  - iii) proton is lost by the atom
  - iv) atom shared by electrons
13. The total no. of electrons that take part in forming a bond in  $N_2$  is
- i) 2
  - ii) 4
  - iii) 6
  - iv) 10
14. Which of the following has the weakest carbon-carbon strength?
- i)  $C_2H_2$
  - ii)  $C_2H_4$
  - iii)  $C_2H_6$
  - iv) all have the same bond strength

15. Which of the following salt when dissolved in water produce hard water.
- calcium sulphate
  - magnesium bicarbonate
  - calcium chloride
  - any of the above
16. Which of the following is not a saturated hydrocarbon ?
- cyclohexane
  - benzene
  - butane
  - isobutane
17. The bond between two identical nonmetallic atom has a pair of electron ?
- unequally shared between two atoms
  - transferred completely from one atom to another
  - With identical spins
  - Equally shared between them
18. Covalent compounds are generally –
- Soluble in water
  - insoluble in water
  - Ionize in water
  - hydrolyse in water
19. Propane with molecular formula  $C_3H_8$  has –
- 7 covalent bonds
  - 8 covalent bonds
  - 9 covalent bonds
  - 10 covalent bonds
20. A hydrocarbon reacts with ammonical cuprous chloride solution to form a red precipitate, the hydrocarbon is –
- Ethane
  - ethane
  - butane
  - 1-propyne
21. Which of the following substance is added to denature Ethanol?
- Methanol
  - pyridine
  - copper sulphate
  - all of these

22. Which of the following is not an allotropic form of carbon ?
- fluorine
  - fullerene
  - diamond
  - graphite
23. Which of the following represents the correct decreasing order of hydrogen atoms ?
- alkanes, alkenes, alkynes
  - alkanes, alkynes, alkenes
  - alkenes, alkynes, alkanes
  - alkynes, alkanes, alkenes
24. Detergents are sodium or potassium salts of long chain of :
- aldehydes
  - ketones
  - carboxylic acid
  - sulphonic acid
25. In double covalent bond there is a sharing of
- 2 electrons
  - 4 electrons
  - 6 electrons
  - 3 electrons
26. Cation is formed when
- atom gains electrons
  - atom loses electrons
  - proton is lost by the atom
  - atom shared by electrons
27. The total number of electrons that take part in forming a bond in  $N_2$  is
- 2
  - 4
  - 6
  - 10
28. Which of the following has the weakest carbon-carbon strength ?
- $C_2H_2$
  - $C_2H_4$
  - $C_2H_6$
  - all have the same bond strength

29. Which of the following salt when dissolved in water produce hard water ?
- calcium sulphate
  - magnesium bicarbonate
  - calcium chloride
  - any of the above.
30. The two colours seen at the extreme ends of the pH charts are:-
- red and blue
  - red and green
  - green and blue
  - orange and green
31. Carboxylic acids on heating with  $P_2O_5$  gives:-
- ethers
  - alcohol
  - carbonyl compounds
  - anhydrides
32. Synthetic flavours contain:-
- unsaturated acids
  - esters
  - dilute carboxylic acids
  - hydroxyl acids
33. Out of the following which one is used as preservative for pickle and sauces:-
- esters
  - acetone
  - aldehyde
  - acetic acid
34. Brisk effervescences produced when a pinch of  $Na_2CO_3$  is added to  $CH_3COOH$  is due to the formation of :-
- $H_2$  gas
  - $CO_2$  gas
  - CO gas
  - $CH_4$  gas
35. When an acetic acid reacts with an alcohol in the presence of conc.  $H_2SO_4$ :-
- esters are formed
  - ketones are formed
  - aldehydes are formed
  - none of these
36. Sodium bi carbonate solution is added to dilute Ethanoic acid. It is observed that:-
- a gas evolves
  - a solid settles at the bottom
  - the mixture becomes vapour
  - the colour of the mixture becomes light Yellow



- 37.** Ethanoic acid was added to sodium bicarbonate sol. And the gas evolved was tested with a burning splinter. The following four observations were reported:-
- 1) the gas burns with the pop sound and the flame gets extinguished.
  - 2) the gas does not burn out but the splinter burns with a pop sound
  - 3) the flame extinguishes and the gas does not burn
  - 4) the gas burns with a blue flame and the splinter burns brightly.
- The correct observation is reported in:-
- i) 1
  - ii) 2
  - iii) 3
  - iv) 4
- 38.** 2ml of ethanoic acid was taken in each test tube 1 and 2 .A red litmus paper was introduced in test tube 1 and a pH paper was introduced in test tube 2. The experiment was performed by 4 students A, B, C, D and they reported their observation as given in the table. Student action on red action on litmus PH paper
- A) Turned blue turned pink
  - B) Remains unchanged turned green
  - C) Turned blue turned blue
  - D) Remains unchanged turned pink
- The correct observation is reported in
- i) A
  - ii) B
  - iii) C
  - iv) D
- 39.** Acetic acid was added to a solid X kept in a Test tube. A colourless, odourless gas Y was evolved. The gas was passed through the lime water, which turned milky. It concludes that:-
- i) solid X is NaOH and the gas Y is CO<sub>2</sub>
  - ii) solid X is Na<sub>2</sub>CO<sub>3</sub> and the gas Y is CO<sub>2</sub>
  - iii) solid X is sodium acetate and the gas y is CO<sub>2</sub>
  - iv) solid X is sodium chloride and the gas Y is CO<sub>2</sub>
- 40.** Why is carbon tetravalent?
- 41.** The formula of a hydrocarbon is C<sub>n</sub>H<sub>2n</sub>. Name the family to which it belongs and also predicts its nature.
- 42.** What is the valency of carbon in CH<sub>3</sub>-CH<sub>3</sub>, CH<sub>2</sub>=CH<sub>2</sub> and HC=CH ?

43. Out of butter and ground nut oil , which is unsaturated in Nature?
44. Why is high temperature not favourable for alcoholic fermentation?
45. Name a cyclic unsaturated hydrocarbon, containing three double bonds?
46. What is the difference in the molecular mass of any two adjacent homologues?
47. Which has triple bond ;  $C_2H_4$  ,  $C_3H_6$  and  $C_3H_4$  ?
48. Which substance is added to denature ethyl alcohol?
49. Which ions are responsible for making water hard?
50. Name the catalyst commonly used in hydrogenation of oil to form fats?
51. Write the name and molecular formula of alcohol derived from butane ?
52. Which gas is evolved when sodium carbonate or bicarbonate is added to ethanoic acid?
53. What is SCUM ?
54. What are hydrophobic and hydrophilic parts in soaps?
55. How much percentage of earth's crust constitutes carbon element ?
56. What do you mean by covalency ?
57. What is covalent bond ?
58. What is functional group ?
59. What is organic chemistry ?
60. What name is given to the reaction which take place when Ethanoic acid reacts with ethanol in the presence of conc. Sulphuric acid ? Name the products obtained in this reaction.
61. What is bromination ? Write the structural formula of product obtained on bromination of propene.
62. Define covalency ?
63. Write the structural formula of the isomers of n-butane?
64. Name the organic acid present in vinegar. Write its Chemical formula also.
65. The structural formula of an ester is  $HCOOCH_2CH_2CH_3$  write the formula of acid and the alcohol from which it is made ?
66. What happens when ethanol reacts with
  - (i) sodium
  - (ii) potassium permanganate solution.
67. Which of the following hydrocarbons undergo addition reactions :  $C_2H_6$ ,  $C_3H_8$ ,  $C_3H_6$ ,  $C_2H_2$  and  $CH_4$ .
68. What is hydrogenation? Write its industrial application.
69. Give a test that can be used to differentiate between butter and cooking oil ?
70. Give the names of the functional group;-

- (i)  $-\text{CHO}$
- (ii)  $-\text{C}=\text{O}$
- (iii)  $-\text{OH}$
- (iv)  $-\text{COOH}$

**71.** Explain the following terms :

- a) Etherification
- b) Saponification
- c) Dehydration

**72.** An organic compound A having molecular formula  $\text{C}_2\text{H}_4\text{O}_2$  reacts with Sodium metal Na evolves a gas B which readily catches fire. A also reacts with Ethanol in the presence of concentrated Sulphuric acid to form a sweet smelling substance C in making perfumes.

- a) Identify the compounds A, B and C.
- b) Write balanced chemical equation to represent the conversion of
  - (i). Compound A to compound B.
  - (ii). Compound A to compound C.

**73.** Give the name of the following :

- a) An Aldehyde derived from Ethane.
- b) Ketone derived from Butane.
- c) The compound obtained by the Oxidation of Ethanol by Chromic anhydride.

**74.** Write chemical equations of the reactions of Ethanoic acid with :

- a) Sodium
- b) Sodium Carbonate
- c) Ethanol in the presence of conc.  $\text{H}_2\text{SO}_4$ .

**75.** Give a test to distinguish between:

- a) Ethane and Ethene
- b) Ethanol with Ethanoic acid.
- c) Soaps and detergents.

**76.** Complete the following reactions:

- a)  $\text{H}_2\text{C}=\text{CH}_2 + \text{H}_2\text{O} \xrightarrow{\text{H}_2\text{SO}_4}$
- b)  $\text{HC}\equiv\text{CH} + \text{Br}_2$
- c)  $\text{C}_2\text{H}_5\text{OH} + \text{Na}$
- d)  $\text{CH}_3\text{COOH} + \text{C}_2\text{H}_5\text{OH}$

**77.** Two carbon compounds A and B have the molecular formula  $\text{C}_3\text{H}_8$  and  $\text{C}_3\text{H}_6$  respectively. Which one of the two each most likely to show addition reaction? Justify your

answer. Explain with the help of a chemical equation, how an addition is useful in vegetable Ghee industry.

- 78.** What substance should be oxidised to prepare acetic acid ( $\text{CH}_3\text{COOH}$ )? How can ethanol and Ethanoic acid be differentiated?
- 79.** Write down the difference between soap and detergents.
- 80.** An organic compound A is widely used as a preservative in pickles and has a molecular formula  $\text{C}_2\text{H}_4\text{O}_2$ . This compound reacts with ethanol to form a sweet smelling compound B.
- Identify the compound A.
  - Write the chemical equation for its reaction with Ethanol to form compound B.
  - How can we get compound A back from B?
  - Name the process and write corresponding chemical equation.
  - Which gas is produced when compound A reacts with washing soda? Write the chemical equation
- 81.** An organic compound X with a molecular formula  $\text{C}_2\text{H}_6\text{O}$  undergoes oxidation with in presence of alkaline  $\text{KMnO}_4$  to form a compound Y. X on heating in presence of Conc.  $\text{H}_2\text{SO}_4$  at 443K gives Z. which on reaction with  $\text{H}_2\text{O}$  in presence of  $\text{H}_2\text{SO}_4$  gives back 'X'. 'Z' reacts with  $\text{Br}_2$  (aq) and decolorizes it. Identify X, Y, & Z. and write the reactions involved.
- 82.** An organic compound 'A' is widely used as a preservative in pickles and has a molecular formula  $\text{C}_2\text{H}_2\text{O}_2$ . This compound reacts with ethanol to form a sweet smelling compound 'B'.
- Identify the compound 'A'
  - Write the chemical equation for its reaction with ethanol to form compound 'B'. (iii) How can we get compound 'A' back from 'B'?
  - Name the process and write corresponding chemical equation.
  - Which gas is produced when compound 'A' reacts with washing soda? Write the chemical equation.
- 83.** Hydrocarbon 'X' and 'Y' having molecular formulae  $\text{C}_3\text{H}_8$  and  $\text{C}_3\text{H}_6$  respectively. Both are burnt in different spatula on the bunsen flame. Indicate the color of the flame produced by 'X' and 'Y'. Identify 'X' and 'Y'. Write the structural formulae.
- 84.** A compound 'X' has molecular formula  $\text{C}_4\text{H}_{10}$ . It undergoes substitution reaction readily than addition reaction. It burns with blue flame and is present in LPG. Identify 'X' and give the balanced equation for its combustion and substitution reaction with  $\text{Cl}_2$  in presence of sunlight.

85. 'A' compound works well with hard water. It is used for making shampoos & products for cleaning clothes. A is not 100% biodegradable and causes water pollution. 'B' does not work well with hard water. It is 100% biodegradable and does not create water pollution. Identify A & B.
86. An organic compound P with molecular formula  $C_2H_6O$  is an active ingredient of all alcoholic drinks. It is also used in medicines such as tincture iodine, cough syrups. Identify 'P'. Drop a small piece of sodium into the test tube containing 'P'. A new compound 'Q' is formed with the evolution of colorless and odorless gas Name the gas evolved and compound 'Q' write the chemical reaction.
87. A cyclic compound 'X' has molecular formula  $C_6H_6$ . It is unsaturated and burns with sooty flame. Identify 'X' and write its structural formula. Will it decolorize bromine water or not and why?
88. An organic compounds 'A' is a constituent of antifreeze and has the molecular formula  $C_2H_6O$ . upon reaction with alkaline  $KMnO_4$ , the compound 'A' is oxidized to another 'B' with formula  $C_2H_6O_2$ . Identify the compound A and 'B'. Write the chemical equation for the reaction which leads to the formulation of 'B'
89. Two compounds 'X' and 'Y' have the same formula  $C_2H_4O_2$ . One of them reacts with sodium metal to liberate  $H_2$  and  $CO_2$  with  $NaHCO_3$ . Second one does not reacts with Na metal and  $NaHCO_3$  but undergo hydrolysis with  $NaOH$  to form salt of carboxylic acid and compound 'Z' which is called wood spirit. Identify 'X', 'Y', and 'Z' and write chemical equation for the reaction involved.
90. A compound 'X' with molecular formula  $C_2H_4$  burns with a sooty flame. It decolourise bromine water. Identify 'X'. Will it dissolve in water or not? Will it conduct electricity in aq. Solution? Will it have high melting point or low melting point ?
- .....

**ASSIGNMENT QUESTIONS SET – 2**  
**CHAPTER – 4**  
**CARBON AND ITS COMPOUND**

1. Carbon exists in the atmosphere in the form of
  - (a) carbon monoxide only
  - (b) carbon monoxide in traces and carbon dioxide
  - (c) carbon dioxide only
  - (d) coal
2. Which of the following statements are usually correct for carbon compounds? These
  - (i) are good conductors of electricity
  - (ii) are poor conductors of electricity
  - (iii) have strong forces of attraction between their molecules
  - (iv) do not have strong forces of attraction between their molecules
  - (a) (i) and (iii) (b) (ii) and (iii)
  - (c) (i) and (iv) (d) (ii) and (iv)
3. A molecule of ammonia ( $\text{NH}_3$ ) has
  - (a) only single bonds
  - (b) only double bonds
  - (c) only triple bonds
  - (d) two double bonds and one single bond
4. Buckminsterfullerene is an allotropic form of
  - (a) phosphorus
  - (b) sulphur
  - (c) carbon
  - (d) tin
5. Oils on treating with hydrogen in the presence of palladium or nickel catalyst form fats.  
This is an example of
  - (a) Addition reaction
  - (b) Substitution reaction
  - (c) Displacement reaction
  - (d) Oxidation reaction
6. In which of the following compounds, — OH is the functional group?
  - (a) Butanone
  - (b) Butanol
  - (c) Butanoic acid
  - (d) Butanal

7. Which of the following are correct structural isomers of butane?

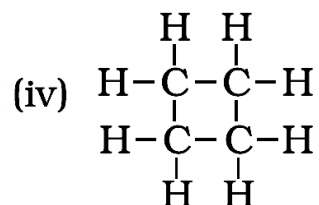
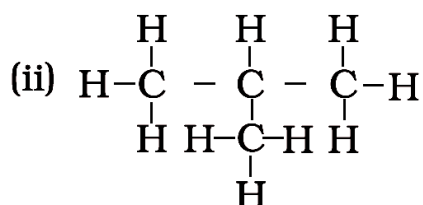
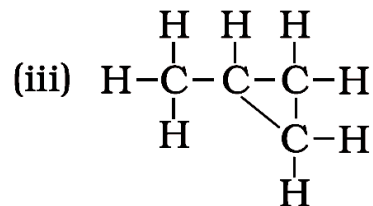
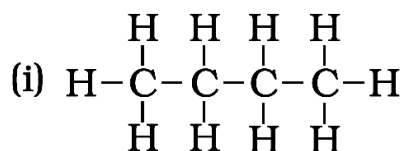

- (a) (i) and (iii) (b) (ii) and (iv)  
 (c) (i) and (ii) (d) (iii) and (iv)

8. In the below given reaction, alkaline  $KMnO_4$  acts as



- (a) reducing agent  
 (b) oxidising agent  
 (c) catalyst  
 (d) dehydrating agent

9. Structural formula of ethyne is

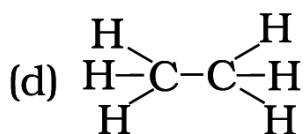
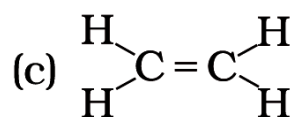
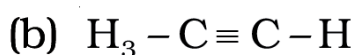

10. The soap molecule has a

- (a) hydrophilic head and a hydrophobic tail  
 (b) hydrophobic head and a hydrophilic tail  
 (c) hydrophobic head and a hydrophobic tail  
 (d) hydrophilic head and a hydrophilic tail

11. Which of the following is the correct representation of electron dot structure of nitrogen?



12. Identify the unsaturated compounds from the following

(i) Propane

(ii) Propene

(iii) Propyne

(iv) Chloropropane

(a) (i) and (ii) (b) (ii) and (iv)

(c) (iii) and (iv) (d) (ii) and (iii)

13. Chlorine reacts with saturated hydrocarbons at room temperature in the

(a) absence of sunlight

(b) presence of sunlight

(c) presence of water

(d) presence of hydrochloric acid

14. In the soap micelles

(a) the ionic end of soap is on the surface of the cluster while the carbon chain is in the interior of the cluster.

(b) ionic end of soap is in the interior of the cluster and the carbon chain is out of the cluster.

(c) both ionic end and carbon chain are in the interior of the cluster

(d) both ionic end and carbon chain are on the exterior of the cluster

15. Pentane has the molecular formula  $\text{C}_5\text{H}_{12}$ . It has

(a) 5 covalent bonds

(b) 12 covalent bonds

(c) 16 covalent bonds

(d) 17 covalent bonds

16. Ethanol reacts with sodium and forms two products. These are

(a) sodium ethanoate and hydrogen

(b) sodium ethanoate and oxygen

(c) sodium ethoxide and hydrogen

(d) sodium ethoxide and oxygen



17. Structural formula of benzene is:

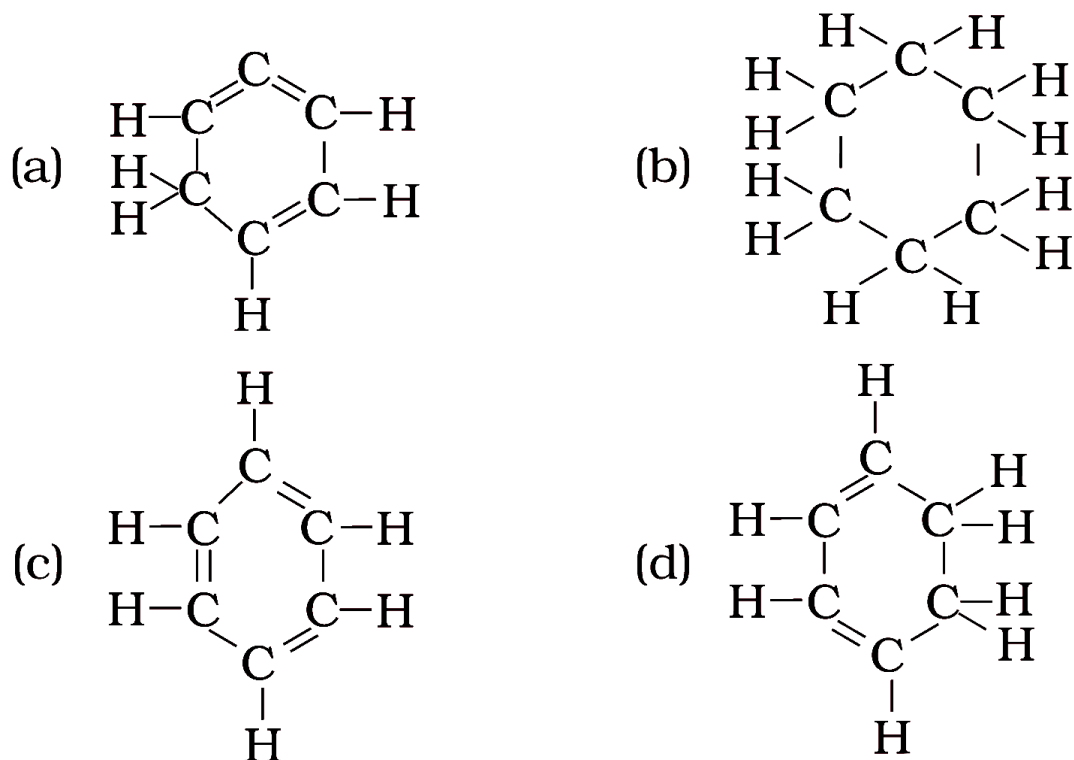

18. The correct structural formula of butanoic acid is

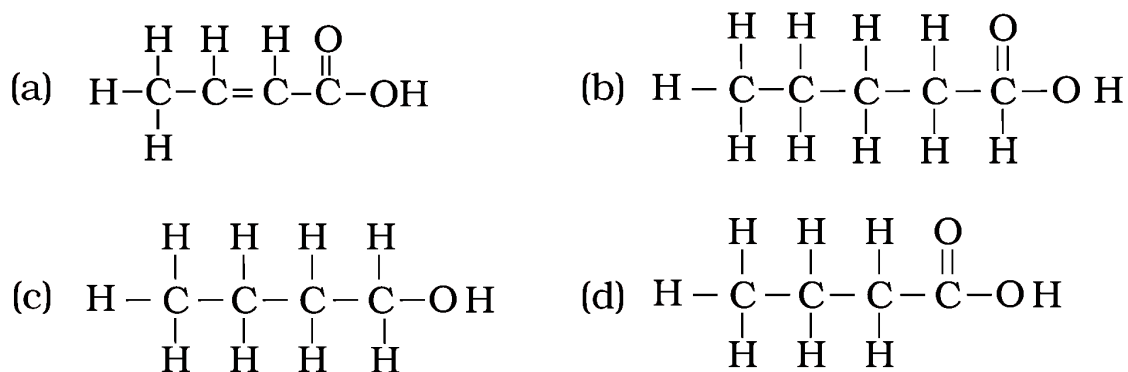

19. Vinegar is a solution of

- (a) 50% – 60% acetic acid in alcohol
- (b) 5% – 8% acetic acid in alcohol
- (c) 5% – 8% acetic acid in water
- (d) 50% – 60% acetic acid in water

20. Mineral acids are stronger acids than carboxylic acids because

- (i) mineral acids are completely ionised
- (ii) carboxylic acids are completely ionised
- (iii) mineral acids are partially ionised
- (iv) carboxylic acids are partially ionised

- (a) (i) and (iv)      (b) (ii) and (iii)      (c) (i) and (ii)      (d) (iii) and (iv)

21. Carbon forms four covalent bonds by sharing its four valence electrons with four univalent atoms, e.g. hydrogen. After the formation of four bonds, carbon attains the electronic configuration of

- (a) helium
- (b) neon
- (c) argon
- (d) krypton

22. The correct electron dot structure of a water molecule is

- (a)  $\text{H} \cdot \ddot{\text{O}} \cdot \text{H}$
- (b)  $\text{H} : \ddot{\text{O}} : \text{H}$
- (c)  $\text{H} : \ddot{\text{O}} : \text{H}$
- (d)  $\text{H} : \text{O} : \text{H}$

23. Which of the following is not a straight chain hydrocarbon?

- (a)  $\text{H}_3\text{C}-\text{CH}_2-\text{CH}_2-\text{CH}_2-\underset{\text{CH}_3}{\text{CH}_2}$
- (b)  $\text{H}_3\text{C}-\text{CH}_2-\text{CH}_2-\text{CH}_2-\text{CH}_2-\text{CH}_3$
- (c)  $\text{H}_2\overset{\text{CH}_3}{\text{C}}-\text{H}_2\text{C}-\text{H}_2\text{C}-\underset{\text{CH}_3}{\text{CH}_2}$
- (d)  $\begin{matrix} \text{CH}_3 \\ \diagdown \\ \text{H}_3\text{C} \end{matrix} \text{CH}-\text{CH}_2-\text{CH}_2-\text{CH}_3$

24. Which among the following are unsaturated hydrocarbons?

- (i)  $\text{H}_3\text{C}-\text{CH}_2-\text{CH}_2-\text{CH}_3$
- (ii)  $\text{H}_3\text{C}-\text{C}\equiv\text{C}-\text{CH}_3$
- (iii)  $\text{H}_3\text{C}-\underset{\text{CH}_3}{\text{CH}}-\text{CH}_3$
- (iv)  $\text{H}_3\text{C}-\underset{\text{CH}_3}{\text{C}}=\text{CH}_2$

- (a) (i) and (iii) (b) (ii) and (iii)
- (c) (ii) and (iv) (d) (iii) and (iv)

25. Which of the following does not belong to the same homologous series?

- (a)  $\text{CH}_4$  (b)  $\text{C}_2\text{H}_6$
- (c)  $\text{C}_3\text{H}_8$  (d)  $\text{C}_4\text{H}_8$

26. The name of the compound  $\text{CH}_3 - \text{CH}_2 - \text{CHO}$  is
- Propanal
  - Propanone
  - Ethanol
  - Ethanal
27. The heteroatoms present in  $\text{CH}_3 - \text{CH}_2 - \text{O} - \text{CH}_2 - \text{CH}_2\text{Cl}$  are
- oxygen
  - carbon
  - hydrogen
  - chlorine
- (i) and (ii) (b) (ii) and (iii)
  - (iii) and (iv) (d) (i) and (iv)
28. Which of the following represents saponification reaction?
- $\text{CH}_3\text{COONa} + \text{NaOH} \xrightarrow{\text{CaO}} \text{CH}_4 + \text{Na}_2\text{CO}_3$
  - $\text{CH}_3\text{COOH} + \text{C}_2\text{H}_5\text{OH} \xrightarrow{\text{H}_2\text{SO}_4} \text{CH}_3\text{COOC}_2\text{H}_5 + \text{H}_2\text{O}$
  - $2\text{CH}_3\text{COOH} + 2\text{Na} \rightarrow 2\text{CH}_3\text{COONa} + \text{H}_2$
  - $\text{CH}_3\text{COOC}_2\text{H}_5 + \text{NaOH} \rightarrow \text{CH}_3\text{COONa} + \text{C}_2\text{H}_5\text{OH}$
29. The first member of alkyne homologous series is
- ethyne
  - ethene
  - propyne
  - methane
30. Draw the electron dot structure of ethyne and also draw its structural formula
31. Why detergents are better cleansing agents than soaps? Explain.
32. Name the functional groups present in the following compounds
- $\text{CH}_3\text{COCH}_2\text{CH}_2\text{CH}_2\text{CH}_3$
  - $\text{CH}_3\text{CH}_2\text{CH}_2\text{COOH}$
  - $\text{CH}_3\text{CH}_2\text{CH}_2\text{CH}_2\text{CHO}$
  - $\text{CH}_3\text{CH}_2\text{OH}$
33. How is ethene prepared from ethanol? Give the reaction involved in it.
34. Intake of small quantity of methanol can be lethal. Comment.
35. A gas is evolved when ethanol reacts with sodium. Name the gas evolved and also write the balanced chemical equation of the reaction involved.

36. Write the names of the following compounds

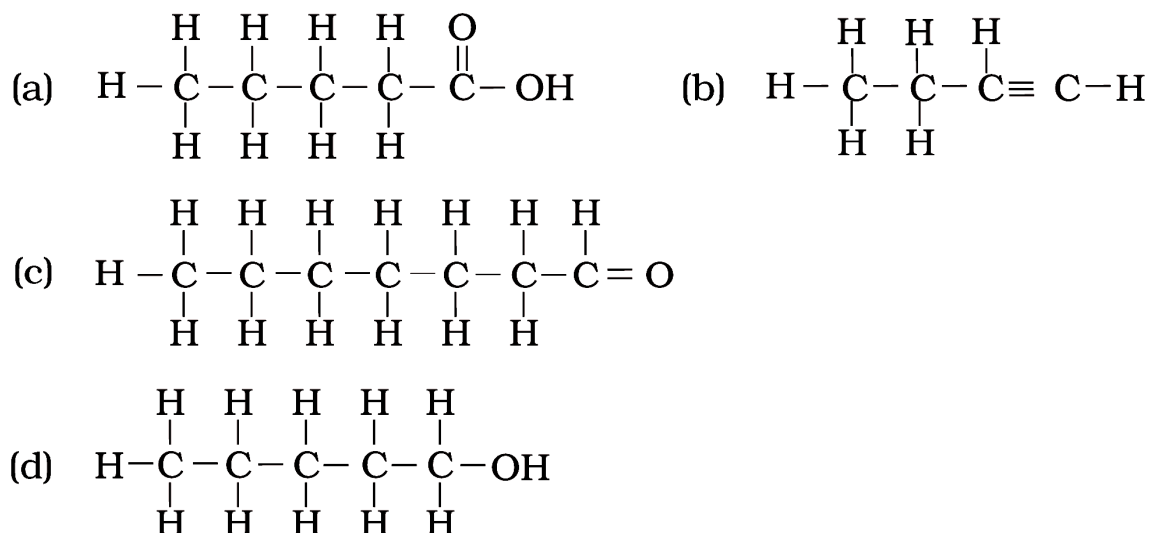

37. Identify and name the functional groups present in the following compounds.

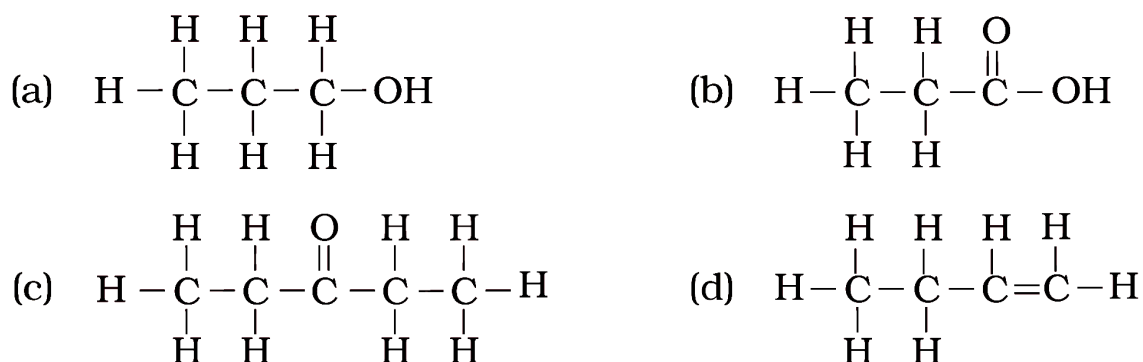

38. A compound X is formed by the reaction of a carboxylic acid  $\text{C}_2\text{H}_4\text{O}_2$  and an alcohol in presence of a few drops of  $\text{H}_2\text{SO}_4$ . The alcohol on oxidation with alkaline  $\text{KMnO}_4$  followed by acidification gives the same carboxylic acid as used in this reaction. Give the names and structures of (a) carboxylic acid, (b) alcohol and (c) the compound X. Also write the reaction.

39. Ethene is formed when ethanol at 443 K is heated with excess of concentrated sulphuric acid. What is the role of sulphuric acid in this reaction? Write the balanced chemical equation of this reaction.

40. Carbon, Group (14) element in the Periodic Table, is known to form compounds with many elements. Write an example of a compound formed with

(a) chlorine (Group 17 of Periodic Table)

(b) oxygen (Group 16 of Periodic Table)

41. In electron dot structure, the valence shell electrons are represented by crosses or dots. (a) The atomic number of chlorine is 17. Write its electronic configuration (b) Draw the electron dot structure of chlorine molecule.

42. Catenation is the ability of an atom to form bonds with other atoms of the same element. It is exhibited by both carbon and silicon. Compare the ability of catenation of the two elements. Give reasons.
43. Unsaturated hydrocarbons contain multiple bonds between the two C-atoms and show addition reactions. Give the test to distinguish ethane from ethene.
44. Write the structural formulae of all the isomers of hexane.
45. What is the role of metal or reagents written on arrows in the given chemical reactions?

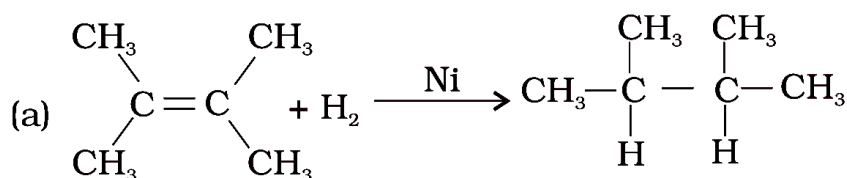

46. A salt X is formed and a gas is evolved when ethanoic acid reacts with sodium hydrogencarbonate. Name the salt X and the gas evolved. Describe an activity and draw the diagram of the apparatus to prove that the evolved gas is the one which you have named. Also, write chemical equation of the reaction involved.
47. What are hydrocarbons? Give examples.
48. Give the structural differences between saturated and unsaturated hydrocarbons with two examples each.
49. What is a functional group? Give examples of four different functional groups.
50. Name the reaction which is commonly used in the conversion of vegetable oils to fats. Explain the reaction involved in detail.
51. Write the formula and draw electron dot structure of carbon tetrachloride.
52. What is saponification? Write the reaction involved in this process.
53. Esters are sweet-smelling substances and are used in making perfumes. Suggest some activity and the reaction involved for the preparation of an ester with well labeled diagram.
54. A compound C (molecular formula,  $\text{C}_2\text{H}_4\text{O}_2$ ) reacts with Na – metal to form a compound R and evolves a gas which burns with a pop sound. Compound C on treatment with an alcohol A in presence of an acid forms a sweet smelling compound S (molecular formula,  $\text{C}_3\text{H}_6\text{O}_2$ ). On addition of NaOH to C, it also gives R and water. S on treatment with NaOH solution gives back R and A. Identify C, R, A, S and write down the reactions involved.
55. Draw the possible isomers of the compound with molecular formula  $\text{C}_3\text{H}_6\text{O}$  and also give their electron dot structures.

- 56.** How would you bring about the following conversions? Name the process and write the reaction involved.
- (a) ethanol to ethene.
  - (b) propanol to propanoic acid.
- Write the reactions.
- 57.** Explain the given reactions with the examples
- (a) Hydrogenation reaction
  - (b) Oxidation reaction
  - (c) Substitution reaction
  - (d) Saponification reaction
  - (e) Combustion reaction
- 58.** An organic compound A on heating with concentrated  $\text{H}_2\text{SO}_4$  forms a compound B which on addition of one mole of hydrogen in presence of Ni forms a compound C. One mole of compound C on combustion forms two moles of  $\text{CO}_2$  and 3 moles of  $\text{H}_2\text{O}$ . Identify the compounds A, B and C and write the chemical equations of the reactions involved.
- 59.** Define Allotropy.
- 60.** What is vinegar ?
- 61.** What is combustion ?
- 62.** How can you differentiate saturated and unsaturated Hydrocarbon on the basis of burning behaviour ?
- 63.** Give two advantages of synthetic detergents over soaps ?
- 64.** What are substitution reactions ?
- 65.** Differentiate between diamond and graphite.
- 66.** Discuss the method of preparation of soap in the laboratory.
- 67.** Write five ill effects of alcohol drinking.
- 68.** Differentiate between ionic compounds and covalent compounds.
- 69.** Give some important properties of ethanol (ethyl alcohol).
- 70.** Give five main advantages of synthetic detergents over soaps.
- 71.** Write important uses of (a) ethanol and (b) ethanoic acid.
- 72.** What happens when ethanol reacts with (i) sodium (ii) potassium permanganate solution.
- 73.** An organic acid 'X' is a liquid which often freezes during winter time in cold countries, has the molecular formula,  $\text{C}_2\text{H}_4\text{O}_2$ . On warming it with ethanol in the presence of a few drops of concentrated sulphuric acid, a compound 'Y' with a sweet smell is formed
- (i) Identify 'X' and 'Y'.
  - (ii) Write a chemical equation for the reaction involved.

74. Write name of the following –
- Alkaline earth metal belonging to the third period
  - The alkali metal atom having largest atomic radius
  - The halogen atom belonging to fourth period
  - The element having lowest ionization energy
  - The element having second lowest electronegativity
75. Organic compound 'x' of molecular formula  $C_2H_4O_2$  gives brisk effervescence with sodium bicarbonate . give name and molecular formula of x with balanced equation
76. Soaps are not considered as effective cleansing agent. Why?
77. How does melting and boiling points of hydrocarbon change with the increase in molecular mass ?
78. Write down the relevant chemical equation involved in decolourisation.
79. A compound X has molecular formula  $C_3H_4$  one mole of X reacts with 2 moles of hydrogen to yield a compound Y deduce the structure of X and Y.
80. What is dehydration reaction? Give one example.
81. What is hydrolysis?
82. Why doesn't soap form micelles in ethanol as they form in water?
83. Three elements X,Y and Z belong to 17TH group but to 2nd 3th and 4th period respectively. Number of valance electrons in X is 7Find the number of valance electrons in X and Z.
84. What is the use of oxyacetylene flame?
85. What is observed on adding 5% solution of alkaline potassium permanganate solution drop by drop to some warm ethanol taken in testube.
86. Write the name of the compound formed during chemical reaction.
87. How would you distinguish experimentally between an alcohol and a carboxylic acid on the basis of a chemical property?
88. Why are vegetable oils healthy as compared to vegetable ghee ? how are vegetable oils converted into vegetable ghee name the process.
89. When acetic acid reacts with X, a salt is formed which on reaction with soda lime gives a gas Y. Identify X and Y
90. "Alkenes form a homologous series" Explain.
91. Why does Ethanoic acid called glacial acetic acid? (Imp.)
92. Why is the conversion of ethanol to ethanoic acid an oxidation reaction? (Imp.)
93. A mixture of ethyne and oxygen is burnt for welding. Can you tell why a mixture of ethyne and air is not used? (Imp.)

94. Why is the conversion of ethanol to ethanoic acid considered an oxidation reaction?
95. Who was the first to suggest the classification of chemical compounds into inorganic compounds and organic compounds?
96. Why are the compounds of carbon studied as a separate branch of chemistry?
97. Compounds like calcium carbide, carbon monoxide, carbon dioxide, calcium carbonate etc., are considered as inorganic compounds although they have carbon atoms in their molecule. Give reason.
98. Why compounds like B-B, Si-Si, and S-S do not exist in nature?
99. What is “Buckminster fullerene”? And why it is called so?
100. Name the first organic compound obtained from an inorganic source in the laboratory. Who synthesized it?
- .....



## CHAPTER – 5

### PERIODIC CLASSIFICATION OF ELEMENTS

In the beginning of 18th century Joseph Louis Proust stated that hydrogen atom is the building material and atoms of all other elements are simply due to the combination of number of hydrogen atoms. (It is to be noted that at his time the atomic weight of all elements were given as whole numbers and the atomic weight of hydrogen was taken as one.)

#### **DOBEREINER'S TRIADS**

A German chemist Johann Wolfgang Dobereiner (1829) noted that there were groups of elements with three elements known as *triads*. Elements in each group or a triad possess with similar chemical properties. Dobereiner discovered that “the relative atomic mass of the middle element in each triad was close to the average of the relative atomic masses of the other two elements”. This statement is called the *Dobereiner's law of Triads*.

Dobereiner's Triads.				
Group	Elements and their Atomic Mass			Arithmetic mean of Atomic mass
A	Lithium(Li)	Sodium(Na)	Potassium(K)	$\frac{7.0 + 39.0}{2} = 23.0$
	7.0	23.0	39.0	
B	Calcium (Ca)	Strontium(Sr)	Barium(Ba)	$\frac{40.0 + 137.0}{2} = 88.5$
	40.0	87.5	137.0	
C	Chlorine(Cl)	Bromine(Br)	Iodine(I)	$\frac{35.0 + 127.0}{2} = 81.0$
	35.0	80.0	127.0	
	55.8	58.9	58.6	

☞ In this table, atomic mass of sodium is equal to arithmetic mean of atomic masses of lithium and potassium. Similarly, atomic mass of strontium is equal to arithmetic mean of atomic masses of calcium and barium.

#### **LIMITATION OF DOBEREINER'S TRIADS:**

- ☞ All the then known elements could not be arranged in the form of triads.
- ☞ The law failed for very low mass or for very high mass elements. In case of F, Cl, Br, the atomic mass of Cl is not an arithmetic mean of atomic masses of F and Br.
- ☞ As the techniques improved for measuring atomic masses accurately, the law was unable to remain strictly valid.

#### **NEWLANDS' LAW OF OCTAVES**

*Newlands law of octaves* states that when elements are arranged in the ascending order of their atomic masses they fall into a pattern in which their properties repeat at regular intervals. Every eighth element starting from a given element resembles in its properties to that of the starting element.

#### **LIMITATION OF NEWLANDS' OCTAVES:**

- ☞ Newlands' Octaves could be valid upto calcium only; as beyond calcium, elements do not obey the rules of Octaves.
- ☞ Newlands' Octaves was valid for lighter elements only.
- ☞ It appears that Newlands did not expect the discovery of more elements than 56 which were discovered till his time.

- ☞ More than one element had to be placed in some of the groups; in order to place the elements having similar properties in one group. But in order to do so, he also put some dissimilar elements in same group.
- ☞ Iron; which has similar property as cobalt and nickel, was placed far from them.
- ☞ Cobalt and nickel were placed in the group with chlorine and fluorine in spite of having different properties.
- ☞ In spite of above limitations; Newlands was the first scientist who arranged the elements in order of their increasing relative atomic masses.

### Newlands' Arranged Elements in Octaves:

H	F	Cl	Co/Ni	Br	Pd	I	Pt/Ir
Li	Na	K	Cu	Rb	Ag	Cs	Tl
G	Mg	Ca	Zn	Sr	Cd	Ba/V	Pb
Bo	Al	Cr	Y	Ce/La	U	Ta	Th
C	Si	Ti	In	Zn	Sn	W	Hg
N	P	Mn	As	Di/Mo	Sb	Nb	Bi
O	S	Fe	Se	Ro/Ru	Te	Au	Os

### INTEXT QUESTIONS PAGE NO. 81

**Q1. Did Dobereiner's triads also exist in the columns of Newlands' Octaves? Compare and find out.**

**Ans:**

Yes. Lithium, sodium and potassium; beryllium; magnesium and calcium are two triads that also exist in the columns of Newland's octaves.

**Q2. What were the limitations of Dbereiner's classification?**

**Ans:**

Please see above notes

**Q3. What were the limitations of Newlands' Law of Octaves?**

**Ans:**

Please see above notes

### **MENDELEEV'S PERIODIC TABLE**

Mendeleef arranged the elements known at that time in a chart in a systematic order in the increasing order of their atomic weights. He divided the chart into 8 vertical columns known as *groups*. Each group is divided into A, B sub groups. Each column contained elements of similar chemical properties.

The elements in the first column, for example, react with oxygen to form compounds with the general formula  $R_2O$ . For example, Li, Na and K when react with oxygen form compounds like  $Li_2O$ ,  $Na_2O$  and  $K_2O$  respectively.

Elements of the second column react with oxygen to form compounds with the general formula  $RO$ . For example, Be, Mg and Ca when react with oxygen form  $BeO$ ,  $MgO$  and  $CaO$ .

Mendeleef tried to explain the similarities of elements in the same group in terms of their common valency.

## THE PERIODIC LAW:

Based on Mendeleeff's observations regarding the properties of elements in the periodic table, a law known as the *periodic law* of the properties of elements was proposed.

"The law states that the physical and chemical properties of the elements are a periodic function of their atomic weights."

## SALIENT FEATURES AND ACHIEVEMENTS OF THE MENDELEEFF'S PERIODIC

### TABLE:

1. Groups and sub-groups: There are eight vertical columns in Mendeleeff's periodic table called as *groups*. They are represented by Roman numerals I to VIII. Elements present in a given vertical column (group) have similar properties. Each group is divided into two sub-group 'A' and 'B'. The elements within any sub-group resemble each other to great extent. For example, sub-group IA elements called 'alkali metals' (Li, Na, K, Rb, Cs, Fr) resemble each other very much.
2. Periods: The horizontal rows in Mendeleeff's periodic table are called *periods*. There are seven periods in the table, which are denoted by Arabic numerals 1 to 7. A period comprises the entire range of elements after which properties repeat themselves.
3. Predicting the properties of missing elements: Based on the arrangement of the elements in the table he predicted that some elements were missing and left blank spaces at the appropriate places in the table.

**Mendeleef believed that some new elements would be discovered definitely. He predicted the properties of these new additional elements in advance purely depending on his table. His predicted properties were almost the same as the observed properties of those elements after their discovery.**

He named those elements tentatively by adding the prefix '*eka*' (*eka is a Sanskrit numeral means one*) to the name of the element immediately above each empty space. The predicted the properties of elements namely eka-aluminium, eka-boron, eka-aluminium and eka-silicon were close to the observed properties of Scandium, Gallium and Germanium respectively which were discovered later.

<i>Properties of some elements as predicted and discovered latter</i>				
Property	Eka-aluminium (Predicted)	Gallium (Actual)	Eka-silicon (Predicted)	Germanium (Actual)
Atomic Mass	68	69.7	72	72.61
Density	5.9 g/cm <sup>3</sup>	5.94 g/cm <sup>3</sup>	5.5 g/cm <sup>3</sup>	5.35 g/cm <sup>3</sup>
Melting point	Low	30.2 <sup>0</sup> C(Low)	High	947 <sup>0</sup> C(High)
Formula of chloride	EaCl <sub>3</sub>	GaCl <sub>3</sub>	EsCl <sub>4</sub>	GeCl <sub>4</sub>
Formula of oxide	Ea <sub>2</sub> O <sub>3</sub>	Ga <sub>2</sub> O <sub>3</sub>	EsO <sub>2</sub>	GeO <sub>2</sub>

4. Correction of atomic mass: the correct placement of elements in Mendeleeff's periodic table helped in correcting the atomic masses of some elements like, Beryllium, Indium, Gold.  
For example, At the time of Mendeleef, beryllium was given atomic weight 13.5.  
Atomic weight = equivalent weight × valency

The equivalent weight of Be was found experimentally as 4.5 and its valency was understood as 3. Therefore atomic weight of beryllium was given as  $4.5 \times 3 = 13.5$ . With this atomic weight it had to be placed in a wrong group in the table. He said that its valency should be only 2 and then its atomic weight then would be  $4.5 \times 2 = 9$ . If atomic weight of 'Be' is 9 it would fit in the second group and its properties practically are similar to Mg, Ca etc., of the second group elements. He also helped in the calculation of the correct atomic weights of 'Indium' and 'Gold' in this manner.

5. Some anomalous series of elements like 'Te' and 'I' were observed in the table. The anomalous series contained element with more atomic weight like 'Te' (127.6 u) placed before the element with less atomic weight like 'I' (126.9 u). Mendeleeff accepted minor inversions in the order of increasing atomic weight when these inversions resulted in elements being placed in the correct groups.

It was the extraordinary thinking of Mendeleeff that made the chemists to accept the periodic table and recognise Mendeleeff more than anyone else as the originator of the periodic law.

### LIMITATIONS OF MENDELEEFF'S PERIODIC TABLE:

1. *Position of hydrogen:* The position of hydrogen in the table is not certain because it can be placed in group IA as well as in group VIIA as it resembles both with alkali metals of IA group and halogens of VIIA group.
2. *Anomalous pair of elements:* Certain elements of highest atomic mass precede those with lower atomic mass.  
For example, *tellurium* (atomic mass 127.6) precedes *iodine* (atomic mass 126.9).  
*Cobalt* and *nickel:* *argon* and *potassium* which were placed in table by deviating the basis of classification (placement in ascending order of atomic masses).  
For example, *potassium* (atomic mass 39) placed after *argon* (atomic mass 40).  
Similar situation was found in pairs of *cobalt* and *nickel* and *tellurium, iodine*.
3. *Dissimilar elements placed together:* elements with dissimilar properties were placed in same group as sub-group A and sub-group B. For example, alkali metal like Li, Na, K etc., of IA group have little resemblance with coinage metals like Cu, Ag, Au of IB group.
4. *Some similar elements separated:* some similar elements like 'copper and mercury' and 'silicon and thalium' etc are placed in different groups of the periodic table.
5. *Position of isotopes:* isotopes of elements are placed in the same position in the table.

### INTEXT QUESTIONS PAGE NO. 85

**Q1. Use MendeléeV's Periodic Table to predict the formulae for the oxides of the following elements:**

**K, C, Al, Si, Ba.**

**Ans:**

Oxygen is a member of group VIA in Mendeleef's Periodic Table. Its valency is 2. Similarly, the valencies of all the elements listed can be predicted from their respective groups. This can help in writing the formulae of their oxides.

(i) **Potassium (K)** is a member of group IA. Its valency is 1. Therefore, the formula of its oxide is  $K_2O$ .

(ii) **Carbon (C)** is a member of group IVA. Its valency is 4. Therefore, the formula of its oxide is  $C_2O_4$  or  $CO_2$ .

(iii) **Aluminium (Al)** belongs to groups IIIA and its valency is 3. The formula of the oxide of the element is  $Al_2O_3$ .

(iv) **Silicon (Si)** is present in group IVA after carbon. Its valency is also 4. The formula of its oxide is  $Si_2O_4$  or  $SiO_2$ .

(v) **Barium (Ba)** belongs to group IIA and the valency of the element is 2. The formula of the oxide of the element is  $Ba_2O_2$  or  $BaO$ .

**Q2. Besides gallium, which other elements have since been discovered that were left by Mendeléev in his Periodic Table? (any two)**

**Ans:**

Scandium and germanium are the two elements that had been left by Mendeleef.

**Q3. What were the criteria used by Mendeléev in creating his Periodic Table?**

**Ans:**

The criteria used by Mendeleef were

- (i) Physical and chemical properties of the elements.
- (ii) Atomic masses in increasing order.

**Q4. Why do you think the noble gases are placed in a separate group?**

**Ans:**

Noble gases are also called inert gases because they have a complete octet and hence, are very stable. They do not react with other elements due to their stability. Since they all are unreactive, have complete octet and similar behaviour so they are placed in a separate group.

### **THE MODERN PERIODIC TABLE**

Based on the modern periodic law, a number of forms of periodic table have been proposed from time to time but general plan of the table remained the same as proposed by Mendeleev. The table which is most commonly used and which is based upon the **electronic configuration of elements** is called the **long form of the periodic table**. This is called the **modern periodic table**.

Long form of the periodic table is a chart of elements in which the elements have been arranged in the increasing order of their atomic numbers. This table consists of **horizontal rows called periods and vertical columns called groups**.

☞ The modern periodic table has also been divided into four blocks known as s, p, d and f blocks.

## Different portions of long form of periodic table

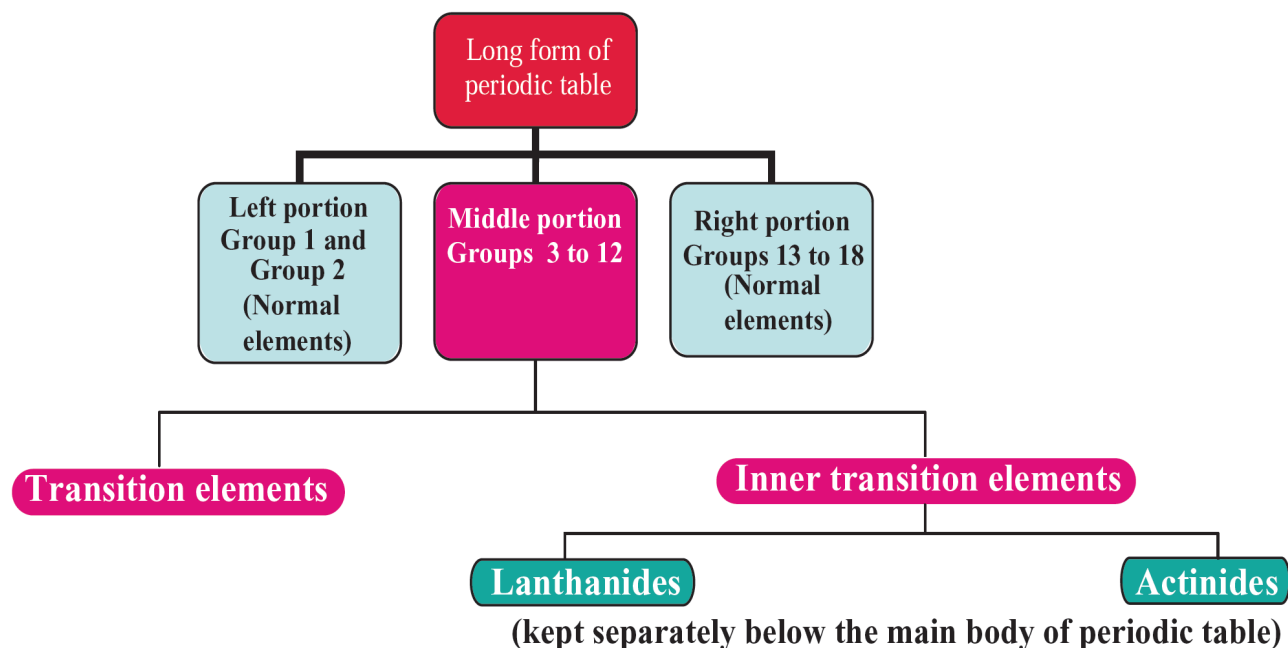

### STUDY OF PERIODS

The **horizontal rows are called periods**. There are **seven** horizontal rows in the periodic table.

- ☞ **First period** (Atomic number 1 and 2): This is the shortest period. It contains only two elements (hydrogen and helium).
- ☞ **Second period** (Atomic number 3 to 10): This is a short period. It contains eight elements (lithium to neon).
- ☞ **Third period** (Atomic number 11 to 18): This is also a short period. It contains eight elements (sodium to argon).
- ☞ **Fourth period** (Atomic number 19 to 36): This is a long period. It contains eighteen elements (potassium to krypton). This includes 8 normal elements and 10 transition elements.
- ☞ **Fifth period** (Atomic number 37 to 54): This is also a long period. It contains 18 elements (rubidium to xenon). This includes 8 normal elements and 10 transition elements.
- ☞ **Sixth period** (Atomic number 55 to 86): This is the longest period. It contains 32 elements (caesium to radon). This includes 8 normal elements, 10 transition elements and 14 inner transition elements (lanthanides).
- ☞ **Seventh period** (Atomic number 87 to 118): As like the sixth period, this period also can accommodate 32 elements. Till now only 26 elements have been authenticated by IUPAC.

### STUDY OF GROUPS

- ☞ Vertical columns in the periodic table starting from top to bottom are called groups. There are 18 groups in the periodic table.
- ☞ First group elements are called alkali metals.
- ☞ Second group elements are called alkaline earth metals.
- ☞ Groups three to twelve are called transition elements .
- ☞ Group 1, 2 and 13 - 18 are called normal elements or main group elements or representative elements .
- ☞ Group 16 elements are called chalcogen family (except polonium).
- ☞ Group 17 elements are called halogen family.
- ☞ Group 18 elements are called noble gases or inert gases.

The lanthanides and actinides which form part of the group 3 are called inner transition elements.

Modern Periodic Table

The zigzag line separates the metals from the non-metals.

Metals

Metalloids

Non-metals

GROUP NUMBER	1	2	GROUP NUMBER										13	14	15	16	17	18						
1	H Hydrogen 1.0																	He Helium 4.0						
2	Li Lithium 6.9	Be Beryllium 9.0																B Boron 10.8	C Carbon 12.0	N Nitrogen 14.0	O Oxygen 16.0	F Fluorine 19.0	Ne Neon 20.2	
3	Na Sodium 23.0	Mg Magnesium 24.3																Al Aluminium 27.0	Si Silicon 28.1	P Phosphorus 31.0	S Sulphur 32.1	Cl Chlorine 35.5	Ar Argon 39.9	
4	K Potassium 39.1	Ca Calcium 40.1	Sc Scandium 45.0	Ti Titanium 47.8	V Vanadium 50.9	Cr Chromium 52.0	Mn Manganese 54.9	Fe Iron 55.9	Co Cobalt 58.9	Ni Nickel 58.7	Cu Copper 63.5	Zn Zinc 65.4	Ga Gallium 69.7	Ge Germanium 72.6	As Arsenic 74.9	Se Selenium 79.0	Br Bromine 79.9	Kr Krypton 83.8						
5	Rb Rubidium 85.5	Sr Strontium 87.6	Y Yttrium 88.9	Zr Zirconium 91.2	Nb Niobium 92.9	Mo Molybdenum 95.9	Tc Technetium (99)	Ru Ruthenium 101.1	Rh Rhodium 102.3	Pd Palladium 106.4	Ag Silver 107.9	Cd Cadmium 112.4	In Indium 114.8	Sn Tin 118.7	Sb Antimony 121.8	Te Tellurium 127.6	I Iodine 126.9	Xe Xenon 131.3						
6	Cs Caesium 132.9	Ba Barium 137.3	La* Lanthanum 138.9	Hf Hafnium 178.5	Ta Tantalum 181.0	W Tungsten 183.9	Re Rhenium 186.2	Os Osmium 190.2	Ir Iridium 192.2	Pt Platinum 195.1	Au Gold 197.0	Hg Mercury 200.6	Tl Thallium 204.4	Pb Lead 207.2	Bi Bismuth 209.0	Po Polonium (210)	At Astatine (210)	Rn Radon (222)						
7	Fr Francium (223)	Ra Radium (226)	Ac** Actinium (227)	Rf Rutherfordium (261)	Db Dubnium (262)	Sg Seaborgium (263)	Bh Bohrium (264)	Hs Hassium (265)	Mt Meitnerium (266)	Ds Darmstadtium (269)	Rg Roentgenium (271)	Uub Ununbium (285)		Uuq Ununquadium (289)		Uuh Ununhexium (295)								

58	Ce Cerium 140.1	Pr Praseodymium 140.9	Nd Neodymium 144.2	Pm Promethium (145)	60	Nd Neodymium 144.2	61	Pm Promethium (145)	62	Sm Samarium 150.4	63	Eu Europium 152.0	64	Gd Gadolinium 157.3	65	Tb Terbium 158.9	66	Dy Dysprosium 162.5	67	Ho Holmium 164.9	68	Er Erbium 167.3	69	Tm Thulium 168.9	70	Yb Ytterbium 173.0	71	Lu Lutetium 175.0
90	Th Thorium 232.0	Pa Protactinium (231)	U Uranium 238.1	Np Neptunium (237)	92	U Uranium 238.1	93	Np Neptunium (237)	94	Pu Plutonium (242)	95	Am Americium (243)	96	Cm Curium (247)	97	Bk Berkelium (245)	98	Cf Californium (251)	99	Es Einsteinium (254)	100	Fm Fermium (253)	101	Md Mendelevium (256)	102	No Nobelium (254)	103	Lr Lawrencium (257)

\* Lanthanoides

\*\* Actinoides

## **CHARACTERISTICS OF MODERN PERIODIC TABLE**

### **CHARACTERISTICS OF PERIODS**

In a period, the electrons are filled in the same valence shell of all elements.

As the electronic configuration changes along the period, the chemical properties of the elements also change.

Atomic size of the elements in a period decreases from left to the right.

In a period, the metallic character of the element decreases while their non-metallic character increases.

### **CHARACTERISTICS OF GROUPS**

- ☞ The elements present in 2 and 18 groups differ in atomic number by 8,8,18,18,32.
- ☞ The elements present in 13 – 17 groups differ in atomic number by 8,18,18,32.
- ☞ The elements present in 4 – 12 groups differ in atomic number by 18,32,32.
- ☞ The elements present in a group have the same number of electrons in the valence shell of their atoms.
- ☞ The elements present in a group have the same valency.
- ☞ The elements present in a group have identical chemical properties.
- ☞ The physical properties of the elements in group such as melting point, boiling point, density vary gradually.
- ☞ Atomic radii of the elements present in a group increases downwards.

### **ADVANTAGES OF THE MODERN PERIODIC TABLE**

- ☞ The table is based on a more fundamental property i.e., atomic number.
- ☞ It correlates the position of the element with its electronic configuration more clearly.
- ☞ The completion of each period is more logical. In a period as the atomic number increases, the energy shells are gradually filled up until an inert gas configuration is reached.
- ☞ It is easy to remember and reproduce.
- ☞ Each group is an independent group and the idea of sub-groups has been discarded.
- ☞ One position for all isotopes of an element is justified, since the isotopes have the same atomic number.
- ☞ The position of eighth group (in Mendeleev's table) is also justified in this table. All transition elements have been brought in the middle as the properties of transition elements are intermediate between left portion and right portion elements of the periodic table.
- ☞ The table completely separates metals from non-metals. The nonmetals are present in upper right corners of the periodic table.
- ☞ The positions of certain elements which were earlier misfit (interchanged) in the Mendeleev's periodic table are now justified because it is based on atomic number of the elements.
- ☞ Justification has been offered for placing lanthanides and actinides at the bottom of the periodic table.



## DEFECTS IN THE MODERN PERIODIC TABLE

- ☞ Position of hydrogen is not fixed till now.
- ☞ Position of lanthanides and actinides has not been given inside the main body of periodic table.
- ☞ It does not reflect the exact distribution of electrons of some of transition and inner transition elements.

## INTEXT QUESTIONS PAGE NO. 90

**Q1. How could the Modern Periodic Table remove various anomalies of Mendeléev's Periodic Table?**

**Ans:**

1. The fundamental basis for Modern Periodic Table is atomic number and not atomic mass and hence, it is more accurate.
2. Properties of elements could be well explained when they were arranged according to their increasing atomic number in the Modern Periodic Table.
3. A separate group for noble gases could be created when noble gases were discovered.
4. Hydrogen has been given a unique position in the Modern Periodic Table at the top left corner because of its unique properties.

**Q2. Name two elements you would expect to show chemical reactions similar to magnesium. What is the basis for your choice?**

**Ans:**

Magnesium (Mg) belongs to group 2 of Modern Periodic Table, known as alkaline earth metal family. The two other elements belonging to the same group are beryllium (Be) and calcium (Ca).

Calcium and magnesium; Beryllium and magnesium - This is because both of them have electronic configuration similar to Mg

<b>Mg</b>	<i>K</i>	<i>L</i>	<i>M</i>	
	2	8	2	
<b>Ca</b>	<i>K</i>	<i>L</i>	<i>M</i>	<i>N</i>
	2	8	8	2
<b>Be</b>	<i>K</i>	<i>L</i>		
	2	2		

These elements belong to the same group and hence, will show similar properties.

**Q3. Name**

- (a) three elements that have a single electron in their outermost shells.
- (b) two elements that have two electrons in their outermost shells.
- (c) three elements with filled outermost shells.

**Ans:**

- |     |         |            |            |
|-----|---------|------------|------------|
| (a) | Li      | Na         | K          |
|     | 2, 1    | 2, 8, 1    | 2, 8, 8, 1 |
| (b) | Mg      | Ca         |            |
|     | 2, 8, 2 | 2, 8, 8, 2 |            |
| (c) | He      | Ar         | Ne         |
|     | 2       | 2, 8       | 2, 8, 8    |

**Q4. (a) Lithium, sodium, potassium are all metals that react with water to liberate hydrogen gas. Is there any similarity in the atoms of these elements?**

**(b) Helium is an unreactive gas and neon is a gas of extremely low reactivity. What, if anything, do their atoms have in common?**

**Ans:**

(a) Li, Na, and K have one electron in their outermost shell.

Li 2, 1 (Atomic number 3)

Na 2, 8, 1 (Atomic number 11)

K 2, 8, 8, 1 (Atomic number 19)

(b) They both have completely filled outer shell.

	<i>K</i>	<i>L</i>	
He	2		(Atomic number 2)
Ne	2	8	(Atomic number 10)

**Q5. In the Modern Periodic Table, which are the metals among the first ten elements?**

**Ans:**

Metals among the first ten elements are lithium and beryllium.

**Q6. By considering their position in the Periodic Table, which one of the following elements would you expect to have maximum metallic characteristic?**

**Ga Ge As Se Be**

**Ans:**

The position of the given elements in the Periodic Table is as.

Ga		Ge	As	Se	Br
(Most metallic)	→	(Least metallic)			

On moving from left to right in a period, size decreases due to increase in effective nuclear charge and hence, tendency to lose electron, *i.e.*, metallic character decreases. Thus Ga has maximum metallic characteristic or metallic nature.

### **EXERCISE QUESTIONS PAGE NO. 91 and 92**

**Q1. Which of the following statements is not a correct statement about the trends when going from left to right across the periods of periodic Table.**

**(a) The elements become less metallic in nature.**

**(b) The number of valence electrons increases.**

**(c) The atoms lose their electrons more easily.**

**(d) The oxides become more acidic.**

**Ans:**

(c) On moving from left to right, the atomic number increases and hence, the nuclear charge increases. With the increase of nuclear charge, the force binding the electron increases so the atom lose the electrons with more difficulty, not easily.

**Q2. Element X forms a chloride with the formula  $XCl_2$ , which is a solid with a high melting point. X would most likely be in the same group of the Periodic Table as**

**(a) Na (b) Mg (c) Al (d) Si**

**Ans:**

(b) The formula of chloride is  $XCl_2$  that means the valency of the element  $X$  is 2. The element having valency 2 will present in group 2. Out of given choices magnesium (Mg) belongs to group 2.

**Q3. Which element has**

- (a) two shells, both of which are completely filled with electrons?
- (b) the electronic configuration 2, 8, 2?
- (c) a total of three shells, with four electrons in its valence shell?
- (d) a total of two shells, with three electrons in its valence shell?
- (e) twice as many electrons in its second shell as in its first shell?

**Ans:**

(a) Noble gases are the elements which have completely filled shells. The noble gas with two shells is Ne having atomic number 10 and electronic configuration 2, 8 both of which are completely filled.

(b) Electronic configuration 2, 8, 2 suggests that atomic number is 12 ( $2 + 8 + 2$ ), magnesium (Mg) has atomic number 12.

(c) The element with three shells and four electrons in the valence shell will have electronic configuration 2, 8, 4. The atomic number of this element is 14 ( $2 + 8 + 4$ ) so it will belong to group 14 hence, it is silicon (Si).

(d) Element with two shells with 3 electrons in the valence shell will exist in second period and will have the electronic configuration 2,3. The atomic number of this element will be 5 ( $2 + 3$ ). So, it will be boron (B).

(e) The element has two shells. we know that first shell can have only 2 electrons, so according to the question there will be 4 electrons (double the number of electrons in first shell). The electronic configuration will be 2, 4, so the atomic number is 6. Hence, the element is carbon (C).

**Q4. (a) What property do all elements in the same column of the Periodic Table as boron have in common?**

**(b) What property do all elements in the same column of the Periodic Table as fluorine have in common?**

**Ans:**

(a) All elements of 13th group, in which boron is present, have 3 electrons in their valence shell (2, 8, 3).

(b) Fluorine belongs to 17th group. All elements of this group have 7 electrons in their valence shell (2, 8, 7). They all show a valency of  $\pm 1$  in their compounds.

**Q5. An atom has electronic configuration 2, 8, 7.**

**(a) What is the atomic number of this element?**

**(b) To which of the following elements would it be chemically similar? (Atomic numbers are given in parentheses.) N(7) F(9) P(15) Ar(18)**

**Ans:**

(a) Atomic number of atom =  $2 + 8 + 7 = 17$

(b) It will be similar to fluorine which is also having 7 electrons in its valence shell [F (2, 7)].

**Q6. The position of three elements A, B and C in the Periodic Table are shown below –**

**Group 16    Group 17**

---	---
---	<b>A</b>
---	---
<b>B</b>	<b>C</b>

**(a) State whether A is a metal or non-metal.**

**(b) State whether C is more reactive or less reactive than A.**

**(c) Will C be larger or smaller in size than B?**

**(d) Which type of ion, cation or anion, will be formed by element A?**

**Ans:**

(a) Since, A belongs to group 1 valence electrons so it is a non-metal because it will gain electron to complete its octet.

(b) C lies below A and in the same group. As we move down in a group, the size increases and electronegative character decreases. With the increase in electronegative character, the electron adapting tendency and hence the reactivities decrease so, C is less reactive than A.

(c) C is smaller than B in size because as we move left to right in a period atomic size decreases.

(d) As discussed in part (a) that element A has a tendency to gain electron to complete its octet. It needs to take up one electron, so it will form anion ( $A^-$ ).

**Q7. Nitrogen (atomic number 7) and phosphorus (atomic number 15) belong to group 15 of the Periodic Table. Write the electronic configuration of these two elements. Which of these will be more electronegative? Why?**

**Ans:**

(a) Electronic configuration of nitrogen and phosphorus:

	<i>K</i>	<i>L</i>	<i>M</i>
<b>N</b>	2,	5	
<b>P</b>	2,	8,	5

(b) N will be more electronegative than P as electronegativity decreases on going down a group in case of non-metals.

**Q8. How does the electronic configuration of an atom relate to its position in the Modern Periodic Table?**

**Ans:**

The number of valence electrons in an atom of an element tells us the group number. *e.g.*, Na has atomic number 11

Electronic configuration of Na (11) =

	<i>K</i>	<i>L</i>	<i>M</i>
	2	8	1

It has one electron in its last shell, thus it belongs to group I of the Periodic Table.

The number of shells in its electronic configuration tells the period number *e.g.*, Na shows 3 shells *K, L, M* so it belongs to 3rd period of the Periodic Table.

**Q9. In the Modern Periodic Table, calcium (atomic number 20) is surrounded by elements with atomic numbers 12, 19, 21 and 38. Which of these have physical and chemical properties resembling calcium?**

**Ans:**

At. no. of element	Electronic configuration				
	<i>K</i>	<i>L</i>	<i>M</i>	<i>N</i>	<i>O</i>
12	2	8	<b>2</b>		
19	2	8	8	1	
21	2	8	8	3	
38	2	8	18	8	<b>2</b>

From the electronic configuration written above we can see that element with atomic number 12 and 38 have 2 electrons in their last shell like calcium. So, they will resemble Ca in their physical and chemical properties.

**Q10. Compare and contrast the arrangement of elements in Mendeléev’s Periodic Table and the Modern Periodic Table.**

**Ans:**

<b>Mendeleev’s periodic table</b>	<b>Modern periodic table</b>
<b>1.</b> Elements are arranged in the increasing order of their atomic masses.	<b>1.</b> Elements are arranged in the increasing order of their atomic numbers.
<b>2.</b> There are a total of 7 groups (columns) and 6 periods (rows).	<b>2.</b> There are a total of 18 groups (columns) and 7 periods (rows).
<b>3.</b> Elements having similar properties were placed directly under one another.	<b>3.</b> Elements having the same valence shell are present in the same period while elements having the same number of valence electrons are present in the same group.
<b>4.</b> The position of hydrogen could not be explained.	<b>4.</b> Hydrogen is placed above alkali metals.
<b>5.</b> No distinguishing positions for metals and non-metals.	<b>5.</b> Metals are present at the left hand side of the periodic table whereas non-metals are present at the right hand side.



**ASSIGNMENT QUESTIONS SET – 1**  
**CHAPTER – 5**  
**PERIODIC CLASSIFICATION OF ELEMENTS**

1. The property of an element in the periodic table depends on its, \_\_\_\_\_.
  - i) atomic size
  - ii) atomic mass
  - iii) electronic configuration
  - iv) number of protons
2. An element has configuration 2, 8, 1. It belongs to, \_\_\_\_\_.
  - i). 1 group and 3rd period
  - ii). 3 group and 1st period
  - iii). 1 group and 8th period
  - iv). 17 group and 3rd period
3. The number of electrons in the valence shell is equal to its \_\_\_\_\_.
  - i). atomic mass
  - ii). group number
  - iii). period number
  - iv). atomic volume
4. The non-metallic element present in the third period other than sulphur and chlorine is
  - i). oxygen
  - ii). fluorine
  - iii). nitrogen
  - iv). phosphorus
5. At the end of each period the valence shell is \_\_\_\_\_.
  - i). incomplete
  - ii). half filled
  - iii). singly occupied
  - iv). completely filled
6. The family of elements having seven electrons in the outermost shell is \_\_\_\_\_.
  - i). alkali metals
  - ii). alkaline earth metals
  - iii). halogens
  - iv). noble gases
7. Which of the following factors does not affect the metallic character of an element?
  - i). Atomic size

- ii). Ionisation potential
  - iii). Electronegativity
  - iv). Atomic radius
8. The family of elements to which potassium belongs is \_\_\_\_\_.
- i). alkali metals
  - ii). alkaline earth metals
  - iii). halogens
  - iv). noble gases
9. The modern periodic table is given by \_\_\_\_\_
- i). Mendeleev
  - ii). Einstein
  - iii). Bohr
  - iv). Mosley
10. Elements belonging to groups 1 to 17 are called \_\_\_\_\_.
- i). noble gases
  - ii). normal elements
  - iii). transition elements
  - iv). inner transition elements
11. A liquid non-metal is \_\_\_\_\_.
- i). phosphorous
  - ii). mercury
  - iii). bromine
  - iv). nitrogen
12. The first alkali metal is \_\_\_\_\_.
- i). hydrogen
  - ii). lithium
  - iii). sodium
  - iv). francium
13. A purple coloured solid halogen is \_\_\_\_\_.
- i). chlorine
  - ii). bromine
  - iii). iodine
  - iv). astatine
14. Lanthanides and actinides are also called \_\_\_\_\_.
- i). normal elements

- ii). transition elements
- iii). noble gases
- iv). inner transition elements

15. The family of elements to which calcium belongs is \_\_\_\_\_.

- i). alkali metals
- ii). alkaline earth metals
- iii). halogens
- iv). noble gases

16. The least reactive element in group 17 is \_\_\_\_\_.

- i). fluorine
- ii). chlorine
- iii). bromine
- iv). iodine

17. The valency of chlorine with respect to oxygen is \_\_\_\_\_.

- i). 1
- ii). 3
- iii). 5
- iv). 7

18. The number of shells in the elements of 3rd period is \_\_\_\_\_.

- i). 1
- ii). 2
- iii). 3
- iv). 0

19. Four elements along a period have atomic number (11, 13, 16 and 17). The most metallic among these has an atomic number of \_\_\_\_\_.

- i). 11
- ii). 12
- iii). 16
- iv). 17

20. Six elements A, B, C, D, E and F have the following atomic numbers (A = 12, B = 17, C = 18, D = 7, E = 9 and F = 11). Among these elements, the element, which belongs to the 3rd period and has the highest ionisation potential, is \_\_\_\_\_.

- i). A
- ii). B
- iii). C



- iv). F
- 21.** A factor that affects the ionisation potential of an element is \_\_\_\_\_.
- i). atomic size
  - ii). electron affinity
  - iii). electro-negativity
  - iv). neutrons
- 22.** The element, which has the highest electron affinity in the 3rd period is \_\_\_\_\_.
- i). Na
  - ii). Mg
  - iii). Si
  - iv). Cl
- 23.** The element, which has zero electron affinity in the 3rd period is \_\_\_\_\_.
- i). Al
  - ii). P
  - iii). Ar
  - iv). S
- 24.** The statement that is not true about electron affinity is
- i). It causes energy to be released
  - ii). It causes energy to be absorbed
  - iii). It is expressed in electron volts
  - iv). It involves formation of an anion
- 25.** Down a group, the electron affinity \_\_\_\_\_.
- i). increases
  - ii). decreases
  - iii). remains same
  - iv). increases and then decreases
- 26.** Name an element with five electrons in the outer shell.
- 27.** Name an element which tends to lose two electrons.
- 28.** Name an element that would tend to gain two electrons.
- 29.** Name the group having a non metal liquid as well as non metal gas at room temperature.
- 30.** Name the group having element with zero valency.
- 31.** Name the metalloid present in group 14.
- 32.** What is the name given to group of three similar elements by Dobereiner?
- 33.** State "Newlands law of Octaves" for classification of elements.
- 34.** Name the fundamental property used by Mendeleev as the basis of classification.

35. How many groups and periods are there in the Modern periodic table?
36. What was the prediction of Mendeleev regarding the gaps in his periodic table?
37. How is valence of an element determined?
38. What will be the valence of an element having atomic number 16?
39. How does valence vary in going down a group?
40. Why inert gases have zero valences?
41. What would be the valence of an atom containing 8 electrons in its outermost shell?
42. How does the electronegative character of elements vary along a period of the periodic table?
43. The present classification of elements is based on which fundamental property of elements?
44. Among first ten elements in the modern periodic table name the metals present.
45. Metals are on which side of Modern periodic table?
46. State Mendeleev's periodic law.
47. Name two elements, other than Gallium, whose existence was predicted by Mendeleev.
48. State Modern Periodic law.
49. Write the name given to the vertical columns in a periodic table.
50. What name is given to the horizontal rows in a periodic table?
51. Why does silicon is classified as Metalloid?
52. State two limitations of Newland's law of Octaves.
53. Name the scientist who proposed modern periodic law? On which fundamental property of elements it is based?
54. Why could no fixed position be given to hydrogen in Mendeleev's Periodic table?
55. What are metalloids? Give two examples.
56. In group 1 of periodic table three elements X, Y and Z have atomic radii 133 pm , 95pm and 65pm respectively giving a reason, arrange them in the increasing order of their atomic number in the group.
57. In modern periodic table, the isotopes of Chlorine Cl-35 and Cl-37 having different atomic masses will be kept in different slots or they would be assigned same position on the basis of their chemical properties? Give reason in support of your answer.
58. Nitrogen (At no. 7) and Phosphorus (At no. 15) belong to group 15 of the periodic table:-
  - (i) Write the electronic configuration of the two.
  - (ii) Predict whether they are metallic or nonmetallic in nature.
59. How and why does the atomic size vary as you go down a group?
60. Why was Dobereiner system of classification of elements into triads not found to be useful?

- 61.** State three merits of Modern periodic table.
- 62.** What are amphoteric oxides? Choose the amphoteric oxide from among the following oxides :-  $\text{Na}_2\text{O}$ ,  $\text{ZnO}$ ,  $\text{Al}_2\text{O}_3$ ,  $\text{CO}_2$ ,  $\text{H}_2\text{O}$
- 63.** Study the variation in the atomic radii of first group elements given below and arrange them in increasing order :-
- |                  |    |    |     |     |     |     |
|------------------|----|----|-----|-----|-----|-----|
| Group I element  | Na | Li | Rb  | Cs  | K   |     |
| Atomic Radii P.M |    | 86 | 152 | 244 | 262 | 231 |
- 64.** An element X has the electronic configuration as 2, 8, 7 :-
- What is the atomic number of the element?
  - What will be the formula of its compound formed with Na?
  - What is the name given to the family of this element?
- 65.** How do you calculate the valence of the element from its electronic configuration? What is the valence of Mg with atomic number 12 and sulphur with atomic number 16? How does the valence vary in going down in a group?
- 66.** Atomic radii of the elements of the period II are as follows:-
- |                      |  |     |    |    |    |    |     |
|----------------------|--|-----|----|----|----|----|-----|
| Period II elements : |  | Be  | B  | O  | N  | C  | Li  |
| Atomic Radius :      |  | 111 | 88 | 66 | 74 | 77 | 152 |
- Arrange them in decreasing order of their atomic radii.
  - How does the atomic size vary on moving from left to right in a period? Explain why?
  - How will the tendency to lose electrons will vary on moving from left to right in this period II?
- 67.** Oxygen (O, 8) and sulphur (S, 16) belong to group 16 of the periodic table:-
- Write the electronic configuration and valence of these two elements?
  - Which among these will be more electronegative? Why?
- 68.** Two elements 'A' and 'B' belong to group 1 and 2 respectively in the same period. Compare them with respect to :-
- Number of valence electrons. (b) Valency
  - Metallic character (d) Size of atom
  - Formulae of their oxides.
- 69.** What is periodicity?
- 70.** Who showed for the first time that there is periodicity in properties of elements?
- 71.** Are the properties of elements placed in a group same?
- 72.** Give reason for the need of classification of elements.
- 73.** Hydrogen can be placed in group 1 and group 7 of periodic table. Why?

74. Name two elements whose properties were correctly predicted by Mendeleev. Mention their present day name.
75. State Mendeleev's periodic law. Why did he leave gaps in his periodic table?
76. An element Z is of second group of the periodic table. Write the formula of its oxide.
77. Noble gases did not find a place in Newland's Octaves. Explain.
78. Give formula for the following:
- (i) bromide of element X of second group.
  - (ii) oxide of element Y of third group.
  - (iii) chloride of element Z of fourth group.
79. How many elements are present in (i) Second period (ii) Six period
80. Name (i) A Non metal solid at room temperature (ii) A Metal liquid at room temperature
81. Arrange the following elements in the decreasing order of metallic character.
- (i) Si, Be, Mg, Na, P
  - (ii) B, Al, Mg, K
82. How in modern periodic table position of elements in groups and periods is decided?
83. Why metallic character decreases across a period and increases down a group?
84. Among the elements of second period 'Li' to 'Ne' pick out the element.
- (i) with the largest atomic radius
  - (ii) that is the most reactive non metal
  - (iii) that is the most reactive metal
  - (iv) which is a metalloid.
85. Elements A, B, C, D, E have following electronic configurations-
- A: 2,3
  - B: 2,8,3
  - C: 2,8,5
  - D: 2,8,7
  - E: 2,8,8,2
- (i) Which of these belong to same group?
  - (ii) Which of these belong to same period?
- .....

**ASSIGNMENT QUESTIONS SET – 2**  
**CHAPTER – 5**  
**PERIODIC CLASSIFICATION OF ELEMENTS**

1. Upto which element, the Law of Octaves was found to be applicable
  - (a) Oxygen
  - (b) Calcium
  - (c) Cobalt
  - (d) Potassium
2. According to Mendeleev's Periodic Law, the elements were arranged in the periodic table in the order of
  - (a) increasing atomic number
  - (b) decreasing atomic number
  - (c) increasing atomic masses
  - (d) decreasing atomic masses
3. In Mendeleev 's Periodic Table, gaps were left for the elements to be discovered later. Which of the following elements found a place in the periodic table later
  - (a) Germanium
  - (b) Chlorine
  - (c) Oxygen
  - (d) Silicon
4. Which of the following statement (s) about the Modern Periodic Table are incorrect
  - (i) The elements in the Modern Periodic Table are arranged on the basis of their decreasing atomic number
  - (ii) The elements in the Modern Periodic Table are arranged on the basis of their increasing atomic masses
  - (iii) Isotopes are placed in adjoining group (s) in the Periodic Table
  - (iv) The elements in the Modern Periodic Table are arranged on the basis of their increasing atomic number
  - (a) (i) only (b) (i), (ii) and (iii)
  - (c) (i), (ii) and (iv) (d) (iv) only
5. Which of the following statements about the Modern Periodic Table is correct:
  - (a) It has 18 horizontal rows known as Periods
  - (b) It has 7 vertical columns known as Periods
  - (c) It has 18 vertical columns known as Groups
  - (d) It has 7 horizontal rows known as Groups

6. Which of the given elements A, B, C, D and E with atomic number 2, 3, 7, 10 and 30 respectively belong to the same period?
- (a) A, B, C
  - (b) B, C, D
  - (c) A, D, E
  - (d) B, D, E
7. The elements A, B, C, D and E have atomic number 9, 11, 17, 12 and 13 respectively. Which pair of elements belong to the same group?
- (a) A and B
  - (b) B and D
  - (c) A and C
  - (d) D and E
8. Where would you locate the element with electronic configuration 2,8 in the Modern Periodic Table?
- (a) Group 8
  - (b) Group 2
  - (c) Group 18
  - (d) Group 10
9. An element which is an essential constituent of all organic compounds belongs to
- (a) group 1
  - (b) group 14
  - (c) group 15
  - (d) group 16
10. Which of the following is the outermost shell for elements of period 2?
- (a) K shell
  - (b) L shell
  - (c) M shell
  - (d) N shell
11. Which one of the following elements exhibit maximum number of valence electrons?
- (a) Na
  - (b) Al
  - (c) Si
  - (d) P
12. Which of the following gives the correct increasing order of the atomic radii of O, F and N ?
- (a) O, F, N
  - (b) N, F, O
  - (c) O, N, F
  - (d) F, O, N

13. Which among the following elements has the largest atomic radii?
- (a) Na
  - (b) Mg
  - (c) K
  - (d) Ca
14. Which of the following elements would lose an electron easily?
- (a) Mg
  - (b) Na
  - (c) K
  - (d) Ca
15. Which of the following elements does not lose an electron easily?
- (a) Na
  - (b) F
  - (c) Mg
  - (d) Al
16. Which of the following are the characteristics of isotopes of an element?
- (i) Isotopes of an element have same atomic masses
  - (ii) Isotopes of an element have same atomic number
  - (iii) Isotopes of an element show same physical properties
  - (iv) Isotopes of an element show same chemical properties
- (a) (i), (iii) and (iv)
  - (b) (ii), (iii) and (iv)
  - (c) (ii) and (iii)
  - (d) (ii) and (iv)
17. Arrange the following elements in the order of their decreasing metallic character  
Na, Si, Cl, Mg, Al
- (a)  $\text{Cl} > \text{Si} > \text{Al} > \text{Mg} > \text{Na}$
  - (b)  $\text{Na} > \text{Mg} > \text{Al} > \text{Si} > \text{Cl}$
  - (c)  $\text{Na} > \text{Al} > \text{Mg} > \text{Cl} > \text{Si}$
  - (d)  $\text{Al} > \text{Na} > \text{Si} > \text{Ca} > \text{Mg}$
18. Arrange the following elements in the order of their increasing nonmetallic character  
Li, O, C, Be, F
- (a)  $\text{F} < \text{O} < \text{C} < \text{Be} < \text{Li}$
  - (b)  $\text{Li} < \text{Be} < \text{C} < \text{O} < \text{F}$
  - (c)  $\text{F} < \text{O} < \text{C} < \text{Be} < \text{Li}$
  - (d)  $\text{F} < \text{O} < \text{Be} < \text{C} < \text{Li}$
19. What type of oxide would Eka- aluminium form?
- (a)  $\text{EO}_3$
  - (b)  $\text{E}_3\text{O}_2$
  - (c)  $\text{E}_2\text{O}_3$
  - (d)  $\text{EO}$





- 28.** Can the following groups of elements be classified as Dobereiner's triad ?  
(a) Na, Si, Cl                      (b) Be, Mg, Ca  
Atomic mass of Be 9; Na 23; Mg 24; Si 28; Cl 35; Ca 40  
Explain by giving reason.
- 29.** In Mendeleev 's Periodic Table the elements were arranged in the increasing order of their atomic masses. However, cobalt with atomic mass of 58.93 amu was placed before nickel having an atomic mass of 58.71 amu. Give reason for the same.
- 30.** "Hydrogen occupies a unique position in Modern Periodic Table". Justify the statement.
- 31.** Write the formulae of chlorides of Eka-silicon and Eka-aluminium, the elements predicted by Mendeleev.
- 32.** Three elements A, B and C have 3, 4 and 2 electrons respectively in their outermost shell. Give the group number to which they belong in the Modern Periodic Table. Also, give their valencies.
- 33.** If an element X is placed in group 14, what will be the formula and the nature of bonding of its chloride?
- 34.** Compare the radii of two species X and Y. Give reasons for your answer.  
(a) X has 12 protons and 12 electrons  
(b) Y has 12 protons and 10 electrons
- 35.** Arrange the following elements in increasing order of their atomic radii.  
(a) Li, Be, F, N                      (b) Cl, At, Br I
- 36.** Identify and name the metals out of the following elements whose electronic configurations are given below.  
(a) 2, 8, 2                              (b) 2, 8, 1  
(c) 2, 8, 7                              (d) 2, 1
- 37.** Write the formula of the product formed when the element A (atomic number 19) combines with the element B (atomic number 17). Draw its electronic dot structure. What is the nature of the bond formed?
- 38.** Arrange the following elements in the increasing order of their metallic character  
Mg, Ca, K, Ge, Ga
- 39.** Identify the elements with the following property and arrange them in increasing order of their reactivity  
(a) An element which is a soft and reactive metal  
(b) The metal which is an important constituent of limestone  
(c) The metal which exists in liquid state at room temperature

- 40.** Properties of the elements are given below. Where would you locate the following elements in the periodic table?
- (a) A soft metal stored under kerosene
  - (b) An element with variable (more than one) valency stored under water.
  - (c) An element which is tetravalent and forms the basis of organic chemistry
  - (d) An element which is an inert gas with atomic number 2
  - (e) An element whose thin oxide layer is used to make other elements corrosion resistant by the process of “ anodising”
- 41.** An element is placed in 2nd Group and 3rd Period of the Periodic Table, burns in presence of oxygen to form a basic oxide.
- (a) Identify the element
  - (b) Write the electronic configuration
  - (c) Write the balanced equation when it burns in the presence of air
  - (d) Write a balanced equation when this oxide is dissolved in water
  - (e) Draw the electron dot structure for the formation of this oxide
- 42.** An element X (atomic number 17) reacts with an element Y (atomic number 20) to form a divalent halide.
- (a) Where in the periodic table are elements X and Y placed?
  - (b) Classify X and Y as metal (s), non-metal (s) or metalloid (s)
  - (c) What will be the nature of oxide of element Y? Identify the nature of bonding in the compound formed
  - (d) Draw the electron dot structure of the divalent halide
- 43.** Atomic number of a few elements are given below 10, 20, 7, 14
- (a) Identify the elements
  - (b) Identify the Group number of these elements in the Periodic Table
  - (c) Identify the Periods of these elements in the Periodic Table
  - (d) What would be the electronic configuration for each of these elements?
  - (e) Determine the valency of these elements
- 44.** In which form matter is present around us?
- 45.** At present, how many elements are known to us?
- 46.** The earliest attempt in classifying elements resulted in the formation of two groups of elements. What are they?
- 47.** Who made the first attempt of classifying elements?
- 48.** On what basis Dobereiner classified elements?
- 49.** Dobereiner classified elements into how many groups?

50. What name was given to Dobereiner groups?
51. What is the total number of elements in Dobereiner groups?
52. How did John Newlands classify elements?
53. Name the first element of Newland's octaves.
54. Name the last element of Newland's octaves.
55. What is your observation from Newland's octaves?
56. What is Newland's Law of octaves?
57. Besides atomic masses, on what other basis were the elements arranged in the Mendeleev's periodic table?
58. Which chemical property of an element was treated as one of the basic property for classifying elements and why?
59. What name is given to vertical columns in Mendeleev's periodic table?
60. What name is given to horizontal rows in Mendeleev's periodic table?
61. While developing the Periodic table, at few places Mendeleev inverted the sequence of some elements i.e. he placed an element with slightly greater atomic mass before the element of lower atomic mass. Why did he do so?
62. Though the atomic mass of cobalt (58.9) is greater than nickel (58.7) yet Co is placed before Ni in Mendeleev's periodic table. Why?
63. Which elements did not exist at the time of Mendeleev's periodic classification? What name was given to these elements?
64. In what way hydrogen resembles alkali metals?
65. In what way hydrogen resembles halogens?
66. Why hydrogen cannot be given a fixed position in periodic table?
67. What is the first limitation of Mendeleev's periodic table?
68. How isotopes of all the elements posed a challenge to Mendeleev's periodic table?
69. Who proposed that atomic number is the more fundamental property for classifying elements?
70. In Modern periodic table, How do elements belonging to the same group resemble each other? Write two points.
71. Different elements have same number of shells, in group or in period?
72. First period of the Modern periodic table contains only two elements. Justify.
73. How many elements are present in second group of the periodic table? Justify.
74. "The valence electrons determine the kind and number of bonds formed by an element". Justify.

75. An element belongs to the first group and third period of the periodic table. What conclusion can you draw from its position ?
76. A metal M forms an oxide having the formula  $M_2O_3$ . It belongs to the third period and thirteenth group of the Modern periodic table. Write the atomic number and valency of the element.
77. What were the two major shortcomings of Mendeleev's periodic table? How have these been removed in the modern periodic table?
78. Two elements X and Y have atomic numbers 12 and 16 respectively. Write the electronic configuration for these elements. To which period of the modern periodic table do these two elements belong? What type of bond will be formed between them and Why?
79. What were the two achievements of Mendeleev's periodic table? What was the basis of classification of elements in it?
80. Atomic radius decreases in moving from left to right in a period. Why?
81. Atomic radius increases down the group. Why?
82. In the modern periodic table a zig-zag line separates metals from non-metals. What are these elements called and why?
83. X, Y and Z are the elements of a Dobereiner's triad. If the atomic mass of X is 7 and that of Z is 39, what should be the atomic mass of Y?
84. A and B are the two elements having similar properties which obey Newlands law of octaves. How many elements are there in between A and B?
85. Why Na is greater in atomic size than  $Na^+$  ?
86. Why does ionization energy generally decrease going down a group or family?
87. An element X (2,8,2) combines separately with  $NO_3^-$  and  $(SO_4)_2^-$ ,  $(PO_4)_3^-$  radicals. Write the formulae of the three compounds so formed. To which group of the periodic table does the element 'X' belong? Will it form covalent or ionic compound? Why?
88. A metal M forms an oxide having the formula  $M_2O_3$ . It belongs to 3rd period in the modern periodic table. Write the atomic number and valency of the metal.
89. Which of the two elements A=2,8,1 B = 2,8,8,1 is more electropositive?
90. How does the atomic size vary in going from A) Left to right in a period B) Top to Bottom in a group
91. An element has atomic number 13. In which group and period it should be placed?
92. How many periods and groups are there in the long form of P.T?
93. Why does the size of the atoms progressively become smaller when we move from sodium (Na) to chlorine (Cl) in the third period of the periodic table ?
94. Give symbols for A. A metal of group 2. B. A metal of group 13. C. Two non metals of group 16. D. Most reactive non- metal of group 17.

**95.** Explain Why-

- (a) All the elements of a group have similar chemical properties.
- (b) All the elements in a period have different chemical properties.

**96.** The atomic number of an element X is 17. Predict –

- A. Its valency.
- B. Nature of the elements.
- C. Whether it is metal or non – metal.
- D. Name of the element.
- E. Relative size with respect to other members of its group.

**97.** The three elements predicted by mendeleev from the gaps in his periodic table were known as eka- boron, eka- aluminum, eka- silicon. What names were given to these elements when they were discovered later on?

**98.** The atomic numbers of Nitrogen, Oxygen and fluorine are 7, 8, and 9 respectively. Write the electronic configuration of each element and answer the following:

- (a) Out of N, O and F which is most electronegative and which one is least electronegative?
- (b) What is the number of valence electrons of F?
- (c) What is the valency of each of N, O and F?



## CHAPTER – 8

### HOW DO ORGANISMS REPRODUCE?

#### **REPRODUCTION**

Reproduction is an integral feature of all living beings. The process by which a living being produces its own like is called reproduction.

#### **IMPORTANCE OF REPRODUCTION:**

Reproduction is important for each species, because this is the only way for a living being to continue its lineage. Apart from being important for a particular individual, reproduction is also important for the whole ecosystem. Reproduction helps in maintaining a proper balance among various biotic constituents of the ecosystem. Moreover, reproduction also facilitates evolution because variations come through reproduction; over several generations.

#### **TYPES OF REPRODUCTION:**

There are two main types, viz. asexual and sexual reproduction.

**Asexual Reproduction:** When a single parent is involved and no gamete formation takes place; the method is called asexual reproduction. No meiosis happens during asexual reproduction.

**Sexual Reproduction:** When two parents are involved and gamete formation takes; the method is called sexual reproduction. Meiosis happens during gamete formation; which is an important step of sexual reproduction.

#### ***INTEXT QUESTIONS PAGE NO. 128***

#### **Q1. What is the importance of DNA copying in reproduction?**

**Ans:**

The importance of DNA copying during reproduction is that:

- (i) It is responsible for the transmission of parental characteristic to its offsprings.
- (ii) It also leads to certain genetic variation.

#### **Q2. Why is variation beneficial to the species but not necessarily for the individual?**

**Ans:**

Variations allow organisms to exist in diverse habitats or niches. In the absence of variations, a species may be restricted to particular area. If this area gets drastically altered, due to various natural or man-made causes, the species may be wiped out. However, if some variations were present in a few individuals, these colonize other habitats and could survive. But if variations are present in a single organism there would be very little for it to survive.

#### **ASEXUAL REPRODUCTION**

#### **MODES OF REPRODUCTION USED BY SINGLE ORGANISMS**

Modes of reproduction involving a single parent, without involving gametes. These are known as asexual modes of reproduction.

Organisms can reproduce asexually in many ways. Some of them are given here.

## FISSION

### ☞ BINARY FISSION

Most of the unicellular animals prefer this method for reproduction. These organisms reproduce by binary fission; especially when conditions are favourable, i.e. adequate amount of food and moisture is available. Binary fission is somewhat similar to mitosis. The mother cell divides into two daughter cells; and each daughter cell begins its life like a new individual. The parent generation ceases to exist, after binary fission. Amoeba is a very good example of the organism which reproduces by binary fission.

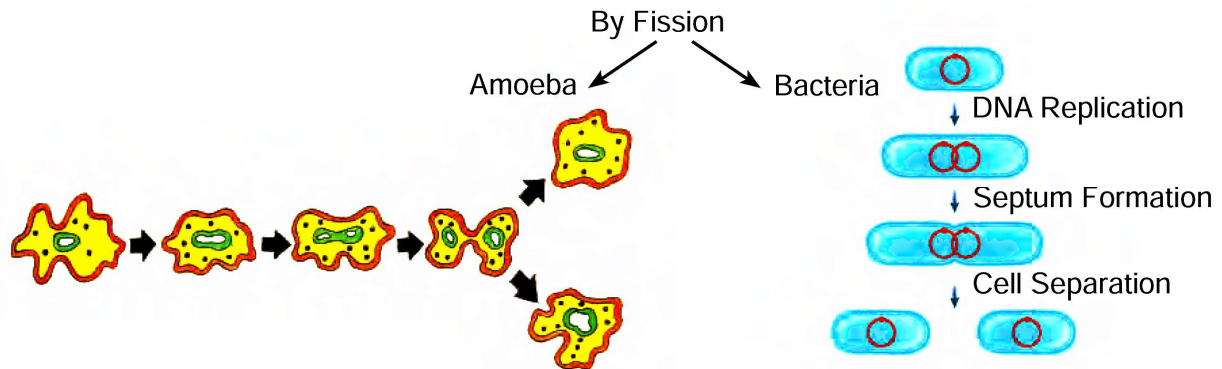

### ☞ MULTIPLE FISSION

When conditions become unfavourable, i.e. food, moisture, proper temperature, etc. are not available; this is the preferred mode of reproduction by unicellular organisms. The organism develops a thick coating around itself. This is called cyst. The nucleus divides into several nuclei and each daughter nucleus is surrounded by a membrane. All metabolic activities stop in the organism, after cyst formation. When favourable conditions return, the cyst dissolves or breaks down; releasing the daughter nuclei. The daughter nuclei; in turn; grow into new individuals. Plasmodium and entamoeba undergo cyst stage, when they are not in the body of their prime host, i.e. humans.

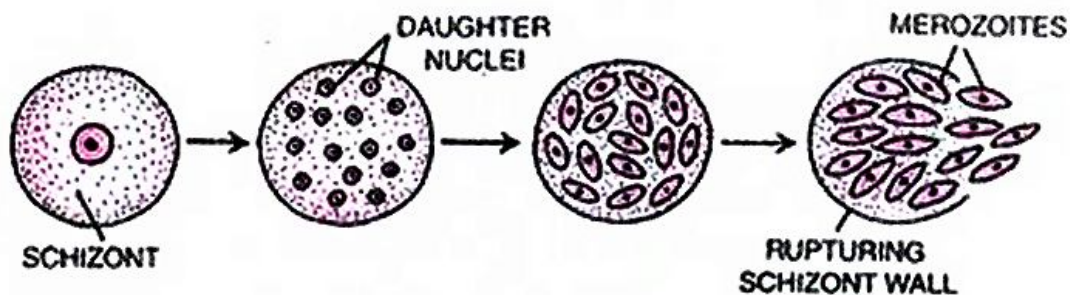

**Multiple Fission in *Plasmodium*.**

## FRAGMENTATION

In multicellular organisms with simple body organization, simple reproductive methods have been noticed. Reproduction by fragmentation is seen in filamentous algae, e.g. spirogyra. In Spirogyra algae, the plant body breaks up into smaller fragments. Each fragment grows into a new individual.

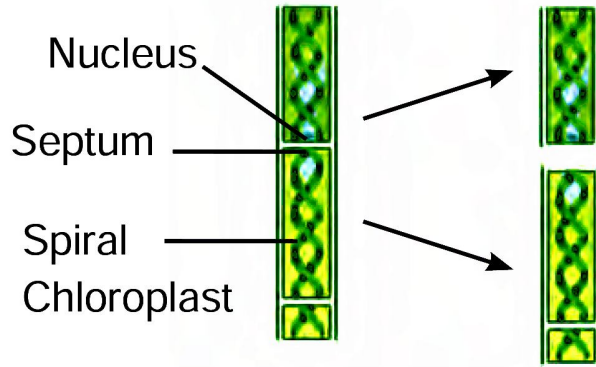

*Fragmentation in Spirogyra*

**REGENERATION**

If the individual is somehow cut or broken up into many pieces, many of these pieces grow into separate individuals. For example, simple animals like Hydra and Planaria can be cut into

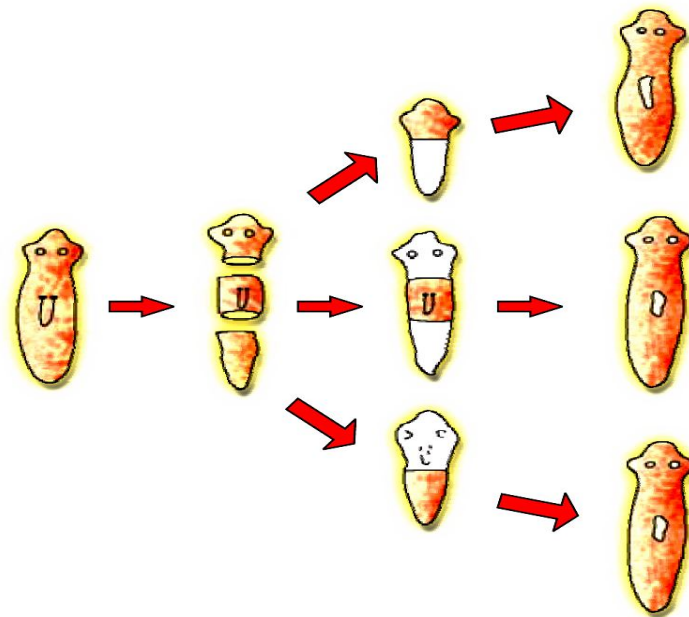

*Regeneration in Planaria*

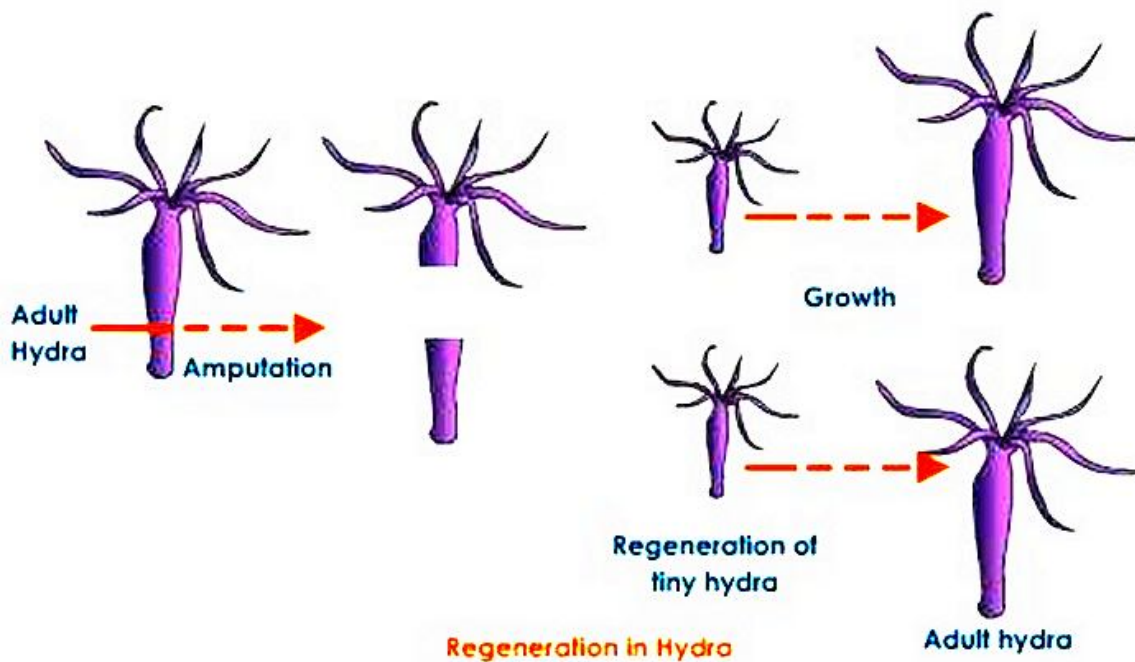

**Regeneration in Hydra**



any number of pieces and each piece grows into a complete organism. This is known as regeneration (see the below figures). Regeneration is carried out by specialised cells. These cells proliferate and make large numbers of cells.

### BUDDING

Organisms such as Hydra use regenerative cells for reproduction in the process of budding. In Hydra, a bud develops as an outgrowth due to repeated cell division at one specific site (see below figure). These buds develop into tiny individuals and when fully mature, detach from the parent body and become new independent individuals.

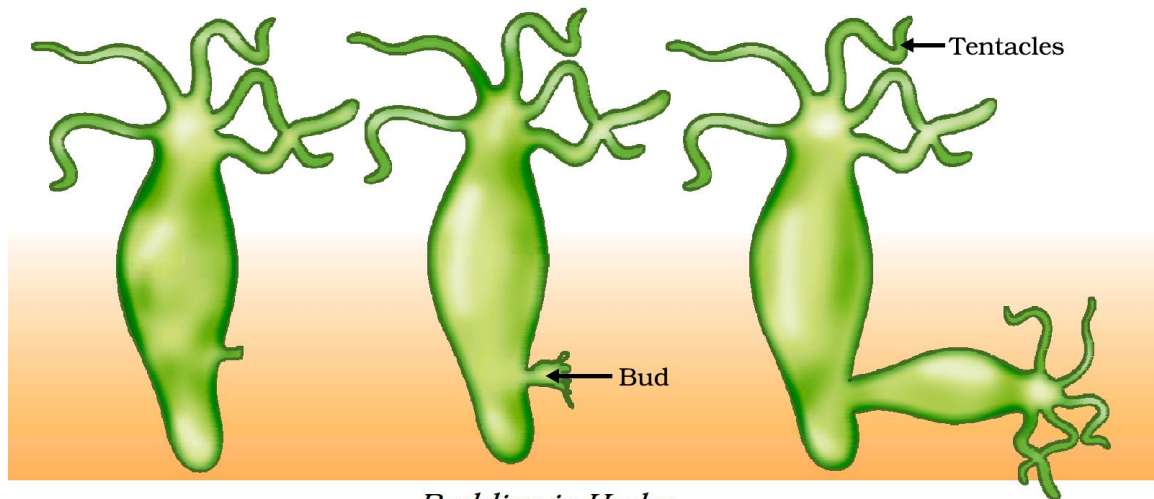

*Budding in Hydra*

### VEGETATIVE PROPAGATION

**Vegetative propagation** is the ability of plants to reproduce by bringing forth new plants from existing vegetative structures without sexual reproduction.

Some examples of vegetative propagation are given below.

**Tuber of Potato:** The potato tuber is a modified stem. Many notches can be seen on the surface of potato. These are called 'eyes' of potato. Each 'eye' of a potato can give rise to a new potato plant. Farmers utilize this capability of potatoes to grow potato more quickly; which is not possible by using the seeds of potato.

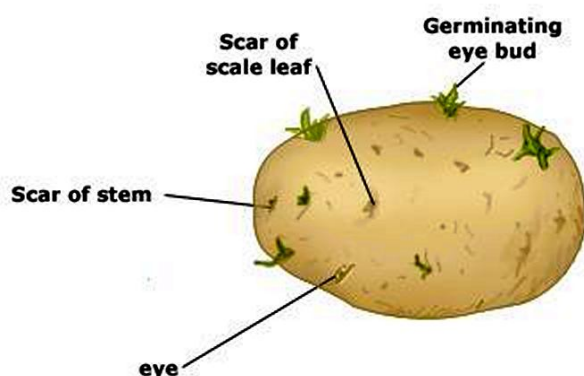

**Modified roots of Carrot and Sweet Potato:** Carrot and sweet potato are examples of modifications of roots; for food storage. These roots can give rise to new plants; when kept under the soil.

**Rhizomes of Ginger and Turmeric:** Rhizomes are examples

of modified underground stems for food storage. These contain nodes, internodes and scaly leaves. When buried under the soil, the rhizomes produce new plants.

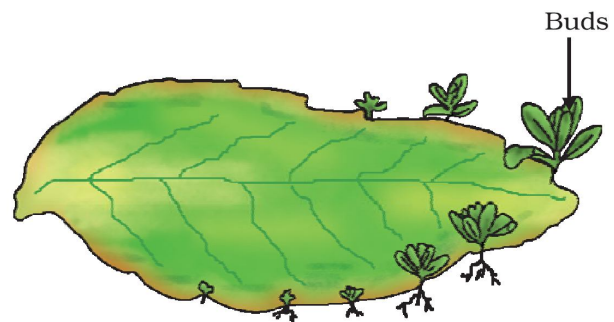
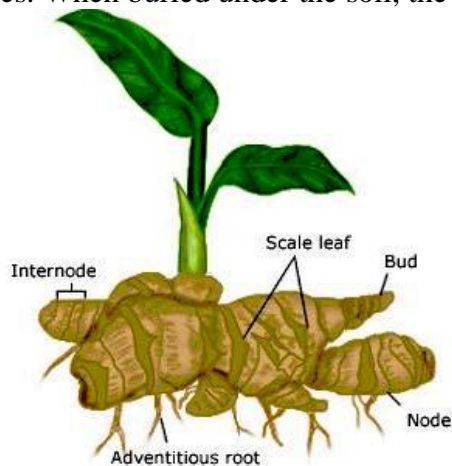

*Leaf of Bryophyllum with buds*

**Leaf of Bryophyllum:** Leaves of bryophyllum have notches on the margin. If a leaf is put under the soil, small saplings grow from the notches on the leaf margin. (see above figure)

**Artificial Vegetative Propagation:** Man has used artificial vegetative propagation to grow many plants. This has enabled farmers and horticulturists to grow many plants in shorter duration and has helped them to earn more profit. Artificial vegetative propagation has also helped in developing many new varieties of plants. Stem cutting, layering and grafting are the preferred means of artificial vegetative propagation.

<p><b>Cutting</b> – A part of stem is cut and the cut end grows into new plant when placed in moist soil e.g. mango, guava, litchi, lemon, rose</p> <p>Leaf cutting      Stem cutting</p>	<p><b>Layering</b> – The stem of a plant is bent down until it touches the soil. The stem is then cut once it develops roots and grows into a new plant. e.g. lemon, rose, jasmine</p>
<p><b>Grafting</b> – The stem of a plant is cut and then fitted on another strong plant and covered with grafting wax. e.g. apples, oranges, water melon, ornamental plants</p>	<p><b>Air Layering</b> – A slanting cut is made in the stem and kept separate with a toothpick. Moss and plastic is wrapped around it till roots grow. Then new plant is cut and planted separately.</p> <p>Ring of bark or tissue removed      Covered by grafting clay      Polythene tied over it</p>

### SPORE FORMATION

Rhizopus produces hundreds of microscopic reproductive units called spores. When the spore case (also called sporangium) bursts, the spores spread into air. These air-borne spores land on food or soil, under favourable conditions like damp and warm conditions, they germinate and produce new individuals. Most of the fungi like Rhizopus, Mucor etc., Bacteria and non-flowering plants such as ferns and mosses reproduce by the method of spore formation.

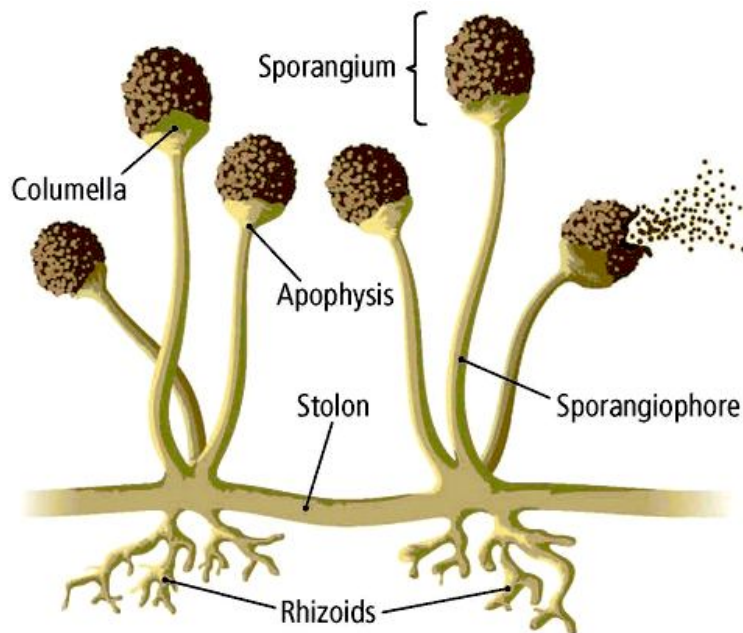

**ADVANTAGES OF ASEXUAL REPRODUCTION:**

- ☞ The organism does not have to depend on another organism for carrying out reproduction; because a single parent is needed.
- ☞ It takes less time than sexual reproduction and hence more number of offspring can be produced in shorter time.
- ☞ The offspring are exact clones of their parent.
- ☞ Desirable characteristics can be easily incorporated into plants with artificial vegetative propagation.

**DISADVANTAGES OF ASEXUAL REPRODUCTION:**

- ☞ As a single parent is involved, so there is negligible chance of variation.
- ☞ In most of the cases in simple organisms, the parent generation ceases to exist after asexual reproduction.
- ☞ Asexual reproduction cannot give rise to biodiversity which is important for a healthy ecosystem.

**INTEXT QUESTIONS PAGE NO. 133**

**Q1. How does binary fission differ from multiple fission?**

**Ans:**

S. No.	<i>Binary Fission</i>	<b>Multiple Fission</b>
1	In binary fission, the parent organism splits to form two new organisms.	In multiple fission, the parent organism splits to form many new organisms at the same time.
2	It takes place during favourable environmental conditions.	It takes place during unfavourable environmental conditions.
3	It takes place in organisms like <i>Amoeba, Paramecium, etc.</i>	It takes place in organisms like <i>Plasmodium.</i>

**Q2. How will an organism be benefited if it reproduces through spores?**

**Ans:** Spores are tiny, spherical, asexual reproductive bodies which under favourable conditions, like damp and warm conditions, germinate to produce new plants. They are covered by the hard protective wall, which enables the plant to survive unfavourable conditions.

**Q3. Can you think of reasons why more complex organisms cannot give rise to new individuals through regeneration?**

**Ans:**

Multicellular organisms cannot reproduce by cell because they are not simple random collection of cells. In them, specialised cells are organized as tissues and tissues are organized into organs, which then have to be kept at different positions in the body. Cell-by-cell division would be impractical. Multicellular organisms, therefore, require to use more complex ways of reproduction.

Moreover, simple multicellular organisms possess special type of tissues which have the potential to grow into a new organism but complex multicellular organisms have no such specialised cells.

**Q4. Why is vegetative propagation practised for growing some types of plants?**

**Ans:**

Vegetative propagation method is used for growing certain plants which do not produce viable seeds. It is also used for growing of plants bearing superior traits, because they produce genetically identical plants. It is also used for growing plants which require longer time to grow and become mature. Plant which require lot of care during early stages of development are also grown by this method.

**Q5. Why is DNA copying an essential part of the process of reproduction?**

**Ans:**

Chromosome in the nucleus of a cell contain information for inheritance of features from parent to next generation in the form of DNA. The DNA in the cell nucleus is the information source of making proteins. Therefore, a basic event in reproduction is creation of DNA copy for the next generation.

**SEXUAL REPRODUCTION**

**SEXUAL REPRODUCTION IN PLANTS**

Sexual reproduction is the process in which two components ( male and female) are involved to produce offsprings of their own kind.

A bull alone cannot produce new calves. It needs a cow. Female sheep alone cannot produce new ones. It needs a male sheep.

Both the sexes, male and female, are needed to produce new offspring.

**PARTS OF A TYPICAL FLOWER**

A flower is a modified shoot with a limited growth.

Flowers vary in size, shape,structure and colour.

The main parts of a flower are,

1. *Calyx*
2. *Corolla*
3. *Androecium and*
4. *Gynoecium.*

Androecium is the male part of a flower,and Gynoecium is the female part.

**Androecium** is a group of stamens. Each Stamen consists of a stalk called the filament and a small

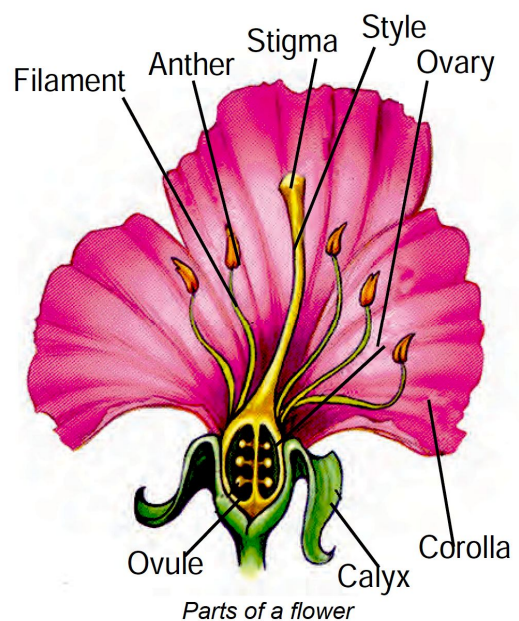

bag like structure called the anther at the tip. The pollen grains are contained in the anther within the pollen sacs.

### **Gynoecium**

Gynoecium is the female part of the flower and consists of the carpels or ovary. Gynoecium has three parts 1) Stigma 2) Style and 3) Ovary. The ovary contains the ovules and each ovule carries within it an embryo sac, within which lies the egg cell or the female gamete.

The sexual reproduction in flowering plants involves

1. Pollination
2. Fertilization

### **1. POLLINATION**

Transfer of pollen grains from the anther to the stigma is called pollination. Pollen grains are transferred mainly by wind, water and insects. They are called as pollinating agents.

Pollination is the first and important event in the development of the fruit and seed. Pollination is followed by fertilization.

### **TYPES OF POLLINATION**

Pollination is of two types. They are

1. Self pollination
2. Cross pollination

### **SELF POLLINATION**

Self pollination is also known as autogamy. The transfer of pollen grains from the anther of a flower to the stigma of the same flower or another flower of the same plant is known as self pollination.

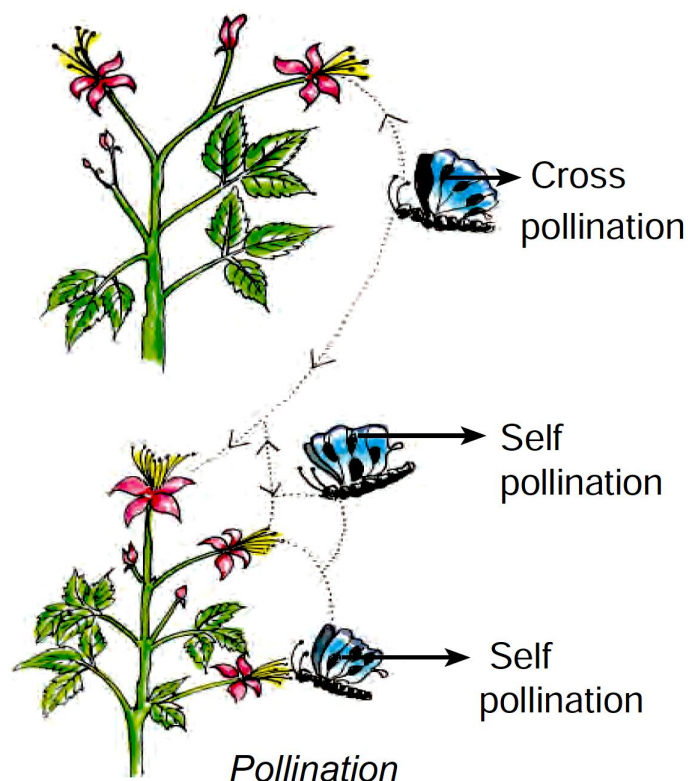

### **ADVANTAGES OF SELF POLLINATION**

- ☞ Self pollination is certain in bisexual flowers.
- ☞ Flowers need not depend on agents of pollination.
- ☞ There is no wastage of pollen grains.

## **DISADVANTAGES OF SELF POLLINATION**

- ☞ The seeds are less in number.
- ☞ Endosperm is minute. Therefore, the seeds produce weak plants.
- ☞ New varieties of plants cannot be produced resulting in the degradation of the plant.

## **CROSS POLLINATION (ALLOGAMY)**

The transfer of pollen grains of a flower to the stigma of another flower of a different plant of the same species is called cross pollination or allogamy.

## **ADVANTAGES OF CROSS POLLINATION**

- ☞ The seeds produced as a result of cross pollination develop, germinate properly and grow into better plants, i.e., cross pollination leads to the production of new varieties.
- ☞ More viable seeds are produced.

## **AGENTS OF CROSS POLLINATION**

In order to bring about cross pollination, it is necessary that the pollen should be carried from one flower to another of a different plant. This takes place through agency of animals, insects, wind and water.

- ☞ Pollination by birds (Ornithophily)
- ☞ Pollination by insects and animals

## **ZOOPHILY**

Animals and insects – Birds, squirrels and insects are attracted to the bright petals of the flowers. These flowers are also large in size and have a sweet smell. Some of these flowers have nectar and a sweet scent. This is the most common of all methods of pollination. This kind of pollination is called Zoophily. (Pollination by animals and birds).

## **ANEMOPHILY (POLLINATION BY WIND)**

The flowers pollinated by air are mostly small in size and without any attractive colour, smell and nectar. They produce a large number of pollen grains to make up for the wastage of pollen in times of transit.

The pollen grains are dry and powdery, and hence are easily carried by the wind. Some pollen grains even have wings. Stigmas are large and protruding, even branched and feathery. e.g. Maize. Flowers pollinated by wind are called Anemophilous, e.g. Grass and pine.

## **POLLINATION BY WATER (HYDROPHILY)**

This pollination takes place in water plants or plants that are adapted to water habitat. e.g. Vallisneria. This pollination is known as hydrophily. The flowers are small and inconspicuous.

## **FERTILIZATION**

Pollination is the transfer of pollen grains from the anther to the stigma. Each pollen grain has protective walls called exine and intine. The outer wall exine is thick and it has small pores called germination pores. The inner wall is thin and elastic.

## **GERMINATION OF POLLEN GRAIN**

If pollen grain falls on a suitable stigma, it starts germinating. A mature pollen consists of

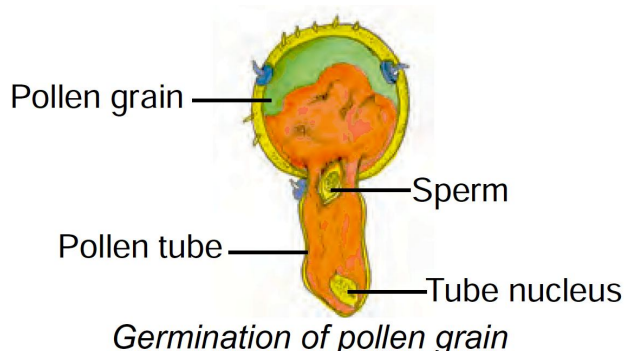

two cells. The larger one is vegetative cell and the smaller one is generative cell. The vegetative cell starts growing and emerges through the germination pore. It develops through the style as a long tube known as pollen tube. The generative cell gets into the tube and divides into two male gametes (sperms).

**PROCESS OF FERTILIZATION**

The pollen tube enters into the embryo sac through micropyle. At this time, the pollen tube bursts open, gametes released from the pollen tube and enter into the embryosac. One of the gametes fuses with the egg, and the other fuses with the secondary nucleus. The fusion of a male gamete with egg is known as fertilization. The fertilized egg is known as zygote which develops into embryo.

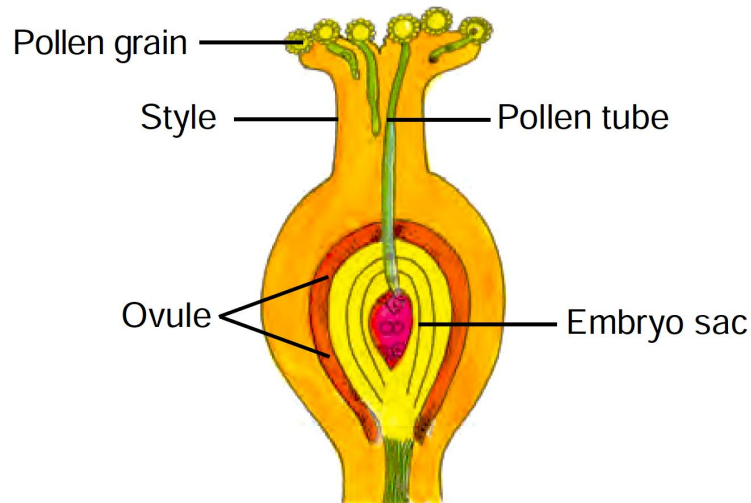

*Process of fertilization*

**DOUBLE FERTILIZATION**

The other male gamete fuses with the secondary nucleus. The secondary nucleus is diploid in nature.

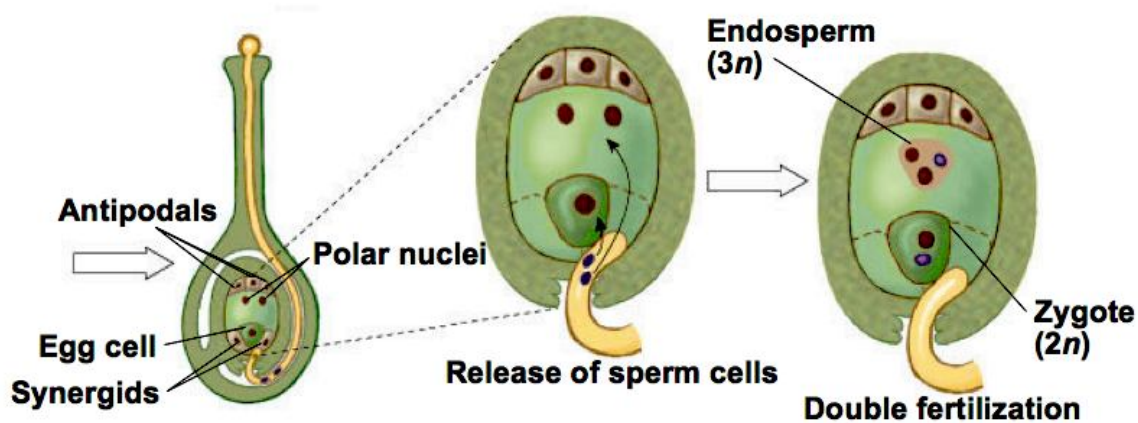

The fusion of this nucleus with the second male gamete is known as triple fusion. The triple fusion nucleus is called endosperm nucleus because it develops into endosperm.

Endosperm is a nutritive tissue meant for the development of the embryo. The process of fusion of a male gamete with egg and the other gamete with secondary nucleus is known as double fertilization.

**POST FERTILIZATION CHANGES :**

- ☞ The ovule develops into seed.
- ☞ The integuments of the ovule develop into seed coats.
- ☞ The ovary enlarges and develops into fruit.

# REPRODUCTION IN HUMAN BEINGS

## MALE REPRODUCTIVE SYSTEM

The male reproductive system in human beings is composed of following parts:

**Testis:** There is a pair of testes; which lie in a skin pouch; called scrotum. Scrotum is suspended outside the body; below the abdominal cavity. This helps in maintaining the temperature of testes below the body temperature. This is necessary for optimum sperm production. Testis primarily serves the function of sperm production. Sperms are the male gametes. Apart from that, testis also produces testosterone. Testosterone is also called the male hormone, as it is responsible for developing certain secondary sexual characters in boys.

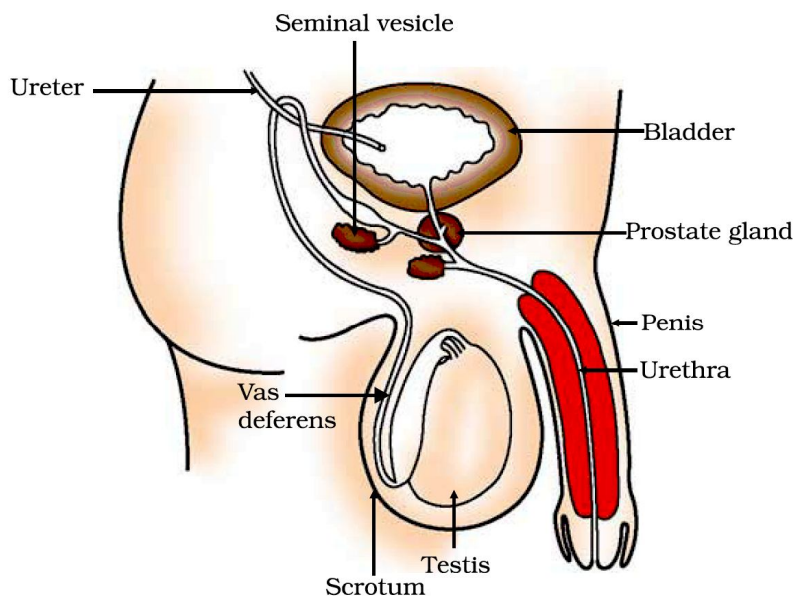

*Human-male reproductive system*

**Vas Deferens:** Vas deferens is the tube which carries sperms to the seminal vesicle.

**Seminal Vesicle:** This is the place where sperms are stored. Secretions from the seminal vesicle and prostate gland add up to make the semen.

**Penis:** It is a muscular organ which serves the genitor-urinary functions. The urethra works as the common passage for urine as well as for sperms.

## FEMALE REPRODUCTIVE SYSTEM

The female reproductive system in human beings is composed of following parts:

**Uterus:** This is pear-shaped hollow muscular organ. Uterus is the place where the embryo gets implanted and develops into a newborn baby. The wall of the uterus provides safety and nutrition to the growing foetus.

**Fallopian Tubes:** One fallopian tube comes out from each side at the top of the uterus. The fallopian tubes end in finger-like structures; called fimbriae. Fertilization happens in the fallopian tube.



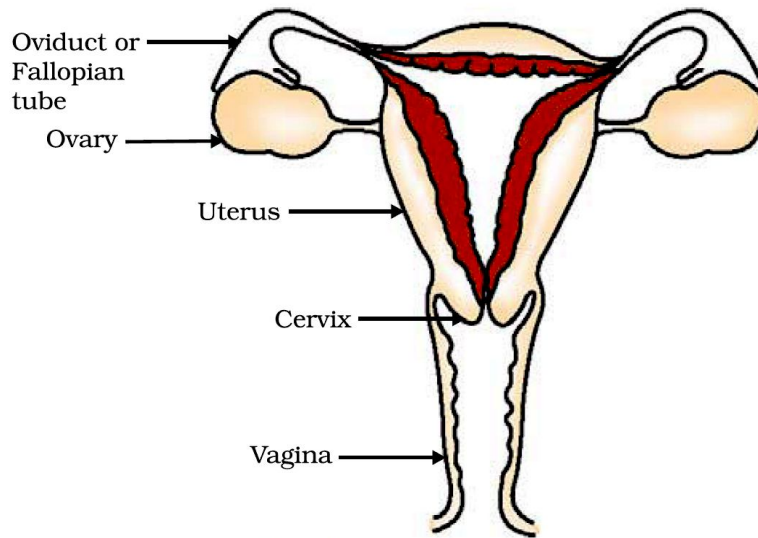

*Human-female reproductive system*

**Ovary:** There are two ovaries; one near each fallopian tube. Ovary produces the eggs or the female gametes. All the eggs are produced by the ovary when the female child is still in the womb. One egg matures in each ovulation cycle and is released from the ovary. The egg is caught by the fimbriae and transferred to the fallopian tube.

**Vagina:** The cervix (mouth of the uterus) opens into the vagina. Vagina is a muscular tube-like organ; which serves as the passage for the sperms and also as the canal during the child birth.

### PUBERTY

Human beings are complex animals and hence there is a distinct phase in their life cycle which marks the onset and attainment of sexual maturity. This period is called puberty. It usually starts at around 10 – 11 years of age in girls and at around 12 – 13 years of age in boys. It usually ends at around 18th year of age in girls and at around 19th year of age in boys. Since the years during puberty end in ‘teens’; hence this phase is also called teenage.

**Changes in Boys during Puberty:** The boys suddenly grow in height dramatically. Voice becomes deep and the Adam’s apple becomes prominent. Shoulders become broad and body becomes muscular. Facial hairs begin to grow. Hairs also grow under the armpit and in the pubic region.

**Changes in Girls during Puberty:** The voice becomes thin. Shoulders and hip become rounded. Breasts get enlarged. Hairs grow under the armpit and in the pubic region.

**Sexual Dimorphism:** The physical dissimilarities in the male and female of a species which give them different appearances is called sexual dimorphism.

**Secondary Sexual Characters:** Features which highlight sexual dimorphism are called secondary sexual characters.

**Menstruation:** Menstruation is a trait which is unique to humans and some primates. During each ovulation cycle, the uterus prepares itself in anticipation of a possible pregnancy. The uterine wall develops an additional lining. When the egg is not fertilized, it gets disintegrated and so does the additional lining in the uterine wall. The fragments of disintegrated tissues are shed; along with blood. This is observed in the form of bleeding through the vagina which can last from 3 to 7 days. The whole sequence of events during an ovulation cycle is called menstrual cycle. The bleeding which occurs for few days is called menstruation. The first

menstrual flow is called menarche and the last menstrual flow (which happens in the late 40s) is called menopause.

## **REPRODUCTIVE HEALTH**

Human beings are different than other animals because they have the power of thinking. They have to obey certain moral values and need to behave sensibly in most of the aspects of life. Beginning of puberty does not mean that a person is psychologically ready for the process of reproduction. For a human being, reproduction involves more than just producing an offspring. As any act of sex has the potential of fertilization, so taking care of contraception becomes important. Moreover, the act of sex also has the potential of creating many sexually transmitted diseases. Examples of STDs are; gonorrhoea, Herpes, syphilis, AIDS, Hepatitis B. AIDS and Hepatitis B are incurable till date. Even the curable STDs are potential dangerous; not only physically but also psychologically.

Reproductive health involves preventing the chances of STDs and preventing unwanted children. Reproductive health means a couple should be able to enjoy the reproductive phase of its life; without taking the burden of gigantic family.

### **INTEXT QUESTIONS PAGE NO. 140**

**Q1. How is the process of pollination different from fertilisation?**

**Ans:**

<b>S. No.</b>	<b>Pollination</b>	<b>Fertilization</b>
<b>1</b>	The transfer of pollen grains from anther to the stigma of a flower is called pollination.	The fusion of male and female gamete to form zygote is called fertilisation.
<b>2</b>	It involves only the male gamete (pollen grain).	It involves both male and female gametes.

**Q2. What is the role of the seminal vesicles and the prostate gland?**

**Ans:**

Secretions from seminal vesicles and prostate gland provide nutrition to the sperms and make their transport easier by providing them a fluid medium.

**Q3. What are the changes seen in girls at the time of puberty?**

**Ans:**

Changes seen in girls at the time of puberty are as follows:

- (i) Growth of hair in armpits and public region.
- (ii) Mammary glands (breast) develop and hips broaden.
- (iii) Uterus, vagina, Fallopian tube enlarge and pelvis widens. Menstruation and ovulation also starts.

**Q4. How does the embryo get nourishment inside the mother's body?**

**Ans:**

The embryo gets nutrition from the mothers blood with the help of special tissue called placenta. This is a disc-like tissue which develops between the uterine wall and embryo. It has villi on embryo side of the tissue. On the mothers side are blood spaces which the villi. This gives a large surface area for oxygen and glucose to pass from the mother to the embryo.

**Q5. If a women is using a copper-T, will it help in protecting her from sexually transmitted diseases?**

**Ans:**

No, copper-T does not prevent the transmission of sexually transmitted diseases. Copper-T only prevents implantation. The only safe method used to prevent the transmission of sexually transmitted diseases is the use of condoms.

### **EXERCISE QUESTIONS PAGE NO. 141**

**Q1. Asexual reproduction takes place through budding in**

- (a) amoeba.
- (b) yeast.
- (c) plasmodium.
- (d) leishmania.

**Ans:**

(b) Asexual reproduction in *Hydra* and yeast takes place by budding.

**Q2. Which of the following is not a part of the female reproductive system in human beings?**

- (a) Ovary
- (b) Uterus
- (c) Vas deferens
- (d) Fallopian tube

**Ans:**

(c) Vas deferens is a part of male reproductive system in human.

**Q3. The anther contains**

- (a) sepals.
- (b) ovules.
- (c) carpel.
- (d) pollen grains.

**Ans:**

(d) Anther is the male reproductive part in plants. It contains pollen grains the first cell of male gametophyte.

**Q4. What are the advantages of sexual reproduction over asexual reproduction?**

**Ans:**

There are a number of advantages of sexual reproduction over asexual one. These include

- (i) Sexual reproduction created variations which are useful for ensuring survival of species and species formation.
- (ii) Two different individuals in a population would have quite different patterns of accumulated variations.
- (iii) The desired phenotype can be promoted by sexual reproduction.

These advantages are not available with asexual reproduction.

**Q5. What are the functions performed by the testis in human beings?**

**Ans:**

Functions of testes

- (i) Produce male sex cells-sperms.
- (ii) Produce male sex hormone testosterone.

**Q6. Why does menstruation occur?**

**Ans:**

Menstruation occurs when the egg is not fertilised. Every month uterus prepares itself to receive a fertilised egg, to nourish the embryo its lining becomes thick and spongy. In case egg

is not fertilised this lining breaks and discharged out of the body through the vagina in the form of blood.

**Q7. Draw a labelled diagram of the longitudinal section of a flower.**

**Ans:**

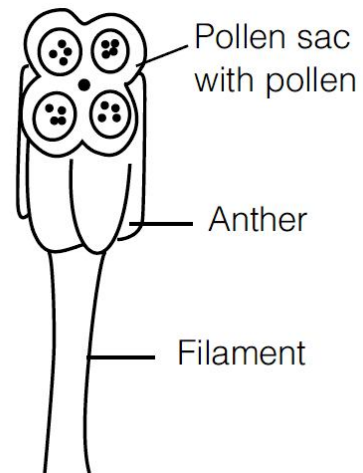
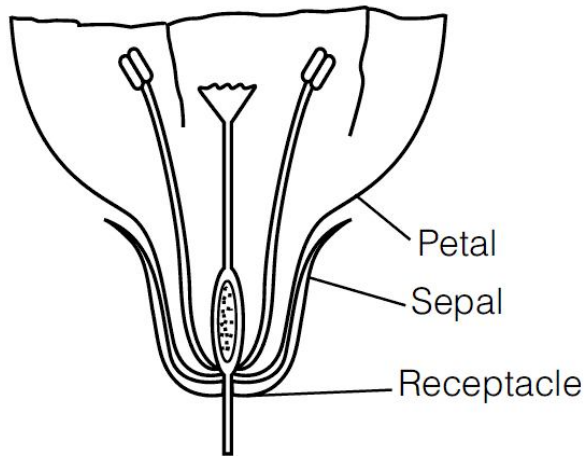

**PARTS**

**Petals (corolla)**

- ☞ Brightly coloured.
- ☞ Attracts insects for pollination.
- ☞ Base contains nectary which produces nectar.

**Sepals (calyx)**

- ☞ Protect the flower while in bud.
- ☞ Generally green and serves to photosynthesize food.

**Receptacle (thalamus)**

- ☞ Base of the flower to which all parts are attached.
- ☞ In some cases, after fertilization become fleshy (apple).

**Pistil (carpel)**

- ☞ Female reproductive part of the flower, known as gynoecium.
- ☞ Comprises of stigma, style and ovary.
- ☞ Stigma is sticky and receives pollen during pollination.
- ☞ Style links stigma to the ovary. It is a elongated tube through which pollen tubes grow.
- ☞ Ovary contains ovules (female gametes), which develop into seeds.

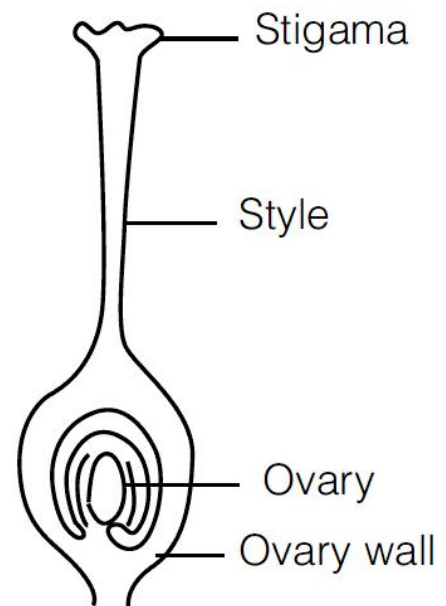

**Stamen**

- ☞ Male reproductive part of the flower, known as androecium.
- ☞ Comprises of anther and filament.
- ☞ Anther is bilobed. Each lobe contains two pollen sacs which produce pollen grains.
- ☞ Filament is the stalk of the stamen that supports anther.

**Q8. What are the different methods of contraception?**

**Ans:**

**The different methods of contraception are:**

- (i) **Barrier Methods** In barrier methods, the physical devices such as condoms and diaphragm are used. Condoms are used by male by putting rubber covering on the penis. They prevent sperms from meeting the egg.
- (ii) **Chemical Methods** In the chemical methods, the females use pills-oral pills and vaginal pills. The oral pills contain hormones which stop ovaries from releasing ovum. The vaginal pills contain the chemicals called spermicides which kill the sperms.
- (iii) **Surgical Methods** In males, a small portion of sperm duct is cut by surgical methods and the cut end is tied properly (vasectomy). This prevents the sperms from coming out. In females, a small part of the oviduct is cut and tied (tubectomy). This prevents the egg from entering the oviduct.

**Q9. How are the modes for reproduction different in unicellular and multicellular organisms?**

**Ans:**

Unicellular organisms are made up of only single cell, in which all the functions are performed by the single cell. So, reproduction is done by simple, asexual methods but in multicellular organisms various cells perform different functions. So, production of all these specialised cells/tissues is required and simple methods for reproduction are insignificant.

**Q10. How does reproduction help in providing stability to populations of species?**

**Ans:**

Reproduction leads to certain variations in the characteristics of the offspring. This may allow organism to exist in diverse habitats and niches. Certain variations present in the individuals of certain population may enable the individuals to survive those unfavourable conditions. Organism with such favourable traits transmit the characters to their offsprings, thereby providing stability to the population of a species.

**Q11. What could be the reasons for adopting contraceptive methods?**

**Ans:**

The reasons for adopting contraceptive methods are:

- (i) To avoid frequent pregnancies, which in turn helps in population control
- (ii) To prevent the spread of sexually transmitted diseases.



**ASSIGNMENT QUESTIONS SET – 1**  
**CHAPTER – 8**  
**HOW DO ORGANISMS REPRODUCE?**

1. Define reproduction.
2. Define fertilization.
3. Where the fertilization does takes place in human female?
4. Name two type of reproduction.
5. What method will you use for growing jasmine and rose plant?
6. Define menstruation.
7. Write the name of male and female reproductive part of a flower.
8. Define gestation period. What is the gestation period in human?
9. Why do testes in mammals descend in scrotum?
10. Name the type of fission carried out by Amoeba.
11. Name two sexually transmitted diseases.
12. What is vegetative propagation?
13. Name the male and female gonads and what are the products they produce.
14. Which part of human female reproduction system is called —birth canal and the —womb?
15. Write the full form of IUCD and AIDS,
16. What is syngamy?
17. What is advantage of fruit formation in plant?
18. What is ovulation?
19. What is menopause?
20. What is the importance of the process of reproduction?
21. What is species?
22. Do organisms produce exact copies of themselves during reproduction?
23. What is the importance of variations?
24. Why is variation beneficial to the species but not necessarily for the individuals?

25. What is the importance of DNA copying in reproduction?
26. What are the different methods of asexual reproduction?
27. Name the following:  
An organism which reproduces by
  - a. Binary fission
  - b. Multiple fission
  - c. Budding
  - d. Fragmentation
  - e. Spore Formation
28. How does binary fission in amoeba differ from binary fission in Leishmania?
29. How will an organism be benefitted if it reproduces through spores?
30. Can you think of reasons why more complex organisms cannot give rise to new individuals through regeneration?
31. Why is vegetative propagation practised for growing some types of plants?
32. What are the advantages of sexual reproduction over asexual reproduction?
33. What is asexual reproduction? Explain briefly various methods of asexual reproduction?
34. How is specific chromosome number maintained in a sexually reproducing organism?
35. Draw and label the parts of a flower.
36. What are the functions of the following parts of a flower?
37. What is pollination?
38. What are the steps involved in fertilization and formation of seeds?
39. What are the secondary sexual characteristics seen in males?
40. Why are the testis located outside the abdominal cavity in the scrotum?
41. Draw the female reproductive system and label the parts.
42. What is ovulation?
43. Draw the longitudinal section of pistil to show pollen grains' germination.
44. List the events after fertilization in an angiosperm takes place.
45. Draw the male reproductive system and label the parts.
46. What is the role of the seminal vesicles and the prostate glands?
47. What are the changes seen in females at the time of puberty?

48. What happens when the egg is not fertilized?
49. How does the embryo get nourishment inside the mother's body?
50. What are the functions performed by the testis in males?
51. How are the modes of reproduction different in unicellular and multi-cellular organisms?
52. How does reproduction help in providing stability to population of species?
53. What could be the reasons for adopting contraceptive methods?
54. What is the importation of DNA copying in reproduction?
55. Why is variation beneficial to the species but not necessarily for the individual?
56. How will an organism be benefited if it reproduces through spores?
57. Can you think of reasons why more complex organisms cannot give rise to new individuals through regeneration?
58. Why vegetative reproduction is practiced for growing some type of plants?
59. Why is DNA copying an essential part of the process of reproduction?
60. What are the changes seen in girl's at the time of puberty?
61. What is the role of the seminal vesicles and the prostate gland?
62. How is the process of pollination different from fertilization?
63. How does the embryo get nourishment inside the mother's body?
64. Show by a series of labeled diagram, the manner in which reproduction in Hydra.
65. Describe regeneration.
66. Define the terms unisexual and bisexual flowers by giving one example of each.
67. Leaves of the bryophyllum fallen on the ground produce new plants whereas the leaves of rose donot. Why?
68. Why does menstruation occur?
69. How does reproduction help in providing stability to populations of species?
70. What is advantages of sexual reproduction over asexual reproduction?
71. What are function performed by testis in human beings.?
72. Differentiate between natural and artificial vegetative propagation.



73. Draw a diagram of a flower to show its male and female reproductive parts. Label on it : a- the ovary b- the anther c- the filament d- the stigma .
74. Describe the fertilization in flower.
75. What is meant by pollination? How it takes place?
76. What is 'vegetative propagation'? Write two examples where it is used. State two reasons of practicing vegetative propagation for giving same types of plants.
77. Illustrate the following with the help of suitable diagram: a) Regeneration in Planaria. b) Budding in Hydra.
78. Describe why : a) Scrotum remains outside the body of human males ? b) Some plants are propagated only by vegetative propagation ?
79. How does reproduction help in providing stability to populations of species ?
80. Describe the changes taking place in female reproductive organs every month
81. What will happen if ovum is not fertilized? Describe the events in a sequence wise manner.
82. How do following organisms reproduce? a) Amoeba b) Planaria c) Yeast d) Frog e) Rose f) Bacteria
- .....

**ASSIGNMENT QUESTIONS SET – 2**  
**CHAPTER – 8**  
**HOW DO ORGANISMS REPRODUCE?**

1. Mention the common mode of reproduction found in (i) Amoeba (ii) Planaria.
2. Name any two types of asexual reproduction.
3. Define reproduction.
4. Name two organisms that show asexual reproduction.
5. How does Hydra reproduce? Name another organism that reproduces by a similar method.
6. What is a spore?
7. Name two plants which reproduce through spores.
8. Why is regeneration considered a method of reproduction?
9. Which vegetative part is used in the propagation of Bryophyllum and mint?
10. Name two types of layering.
11. Name some plants where layering is used.
12. Which technique would you use for propagating improved varieties of mango and rose?
13. Name various types of asexual reproduction.
14. Mention the reproductive parts of a flower.
15. Define fertilisation.
16. What is self-pollination?
17. What is cross pollination?
18. What are the agents of pollination?
19. Which process results in formation of zygote?
20. What grows to form a fruit?
21. What is carpel?
22. Which parts of the flower transform into the seed and fruit?
23. What are gonads?
24. What is puberty?
25. When is ovum released in human female?
26. What is endometrium?
27. What is implantation?
28. What is parturition?
29. What is ovulation?
30. Where are the ova produced in woman?
31. Name two sex hormones.
32. What is the normal reproductive life in human female?

33. What are oral contraceptives?
34. What is epididymis?
35. What are the functions of urethra?
36. What are the secondary sex characters in human male?
37. Why do testes lie outside the abdominal cavity?
38. When does puberty occur in human male and female?
39. State the methods used for growing rose plants.
40. State what type of method is used for growing jasmine plant.
41. Name the hormone, secretion of which is responsible for dramatic changes in appearance in girls when they approach 10-12 years of age.
42. The organisms formed by asexual reproduction are considered as clones. Why? State the advantage of sexual reproduction over asexual reproduction.
43. What is the effect of DNA copying which is not perfectly accurate on the reproduction process?
44. How does the process of budding differ from the process of spore formation?
45. Name the type of asexual reproduction in : (a) *Planaria* (b) *Rhizopus* (iii) *Spirogyra* (iv) *Hydra*
46. With the help of a diagram only show regeneration in *Planaria*. Regeneration is not possible in all types of animals. Why?
47. How does the process of seed germination take place in plants? Describe in brief.
48. Name the sex hormones secreted by male and female sex organs in human beings. State one function of each.
49. State the mode of reproduction in following organisms : Earthworm, Frog, *Rhizopus*, *Plasmodium*.
50. State in brief any two functions of copper-T used by some women.
51. In what respect is the human male gamete different from the female gamete?
52. What is reproduction? What are its two types? Which one of the two confers new characteristics on the offsprings and how?
53. What is binary fission? Draw a diagram to show binary fission in *Amoeba*.
54. What is regeneration? State a reason why a more complex organism cannot give rise to new individuals through this method.
55. Name the male and female gametes in animals. What is fertilisation and where does it take place in human females?
56. What is 'reproduction'? Mention the importance of DNA copying in reproduction.

57. Mention the information source of making proteins in the cell. What is the basic event in reproduction?
58. Name one sexually transmitted disease each caused due to bacterial infection and viral infection. How can these be prevented?
59. Describe briefly four ways in which individuals with a particular trait may increase in a population.
60. Why is it said that —sexual reproduction promotes diversity of characters in the offspring?
61. Why cannot fertilisation take place in flowers if pollination does not occur?
62. Why does bread mould grow profusely on a moist slice of bread rather than on a dry slice of bread?
63. Leaves of Bryophyllum fallen on the ground produce new plants whereas the leaves of Jasmine do not, why?
64. What is clone? Why do offspring formed by asexual reproduction exhibit remarkable similarity?
65. Write one disadvantage of asexual reproduction. When and how does multiple fission take place?
66. State in brief the function of the following organs in the human female reproductive system. (a) Ovary (b) Fallopian tube (c) Uterus
67. Differentiate between : (a) Asexual and sexual reproduction. (b) Plumule and Radicle (c) Pollination and Fertilisation
68. Why is vegetative propagation practised for growing some types of plants? (b) Name the different parts of a flower that has germ cells. (c) List any two agents of pollination.
69. What happens to the pollen which falls on a suitable stigma? Explain.
70. List and describe in brief any three ways devised to avoid pregnancy.
71. What are sexually transmitted diseases? Name four such diseases. Which one of them damages the immune system of human body?
72. Define grafting. Suggest any two advantages and disadvantages of grafting.
73. Name any two mechanical barriers of pregnancy. What are the benefits of using mechanical barriers during sexual act?
74. State in brief the functions of the following parts of the human male reproductive system : (i) Scrotum (ii) Testes (iii) Vas deferens
75. State the role of ovary and fallopian tube in human body.
76. What could be the possible reason for declining female to male sex ratio in our country. Suggest two measures to achieve 1:1 ratio.
77. What is the advantage of reproducing through spores?

78. How does variation lead to the survival of species overtime?
79. What will happen when :
- A mature *Spirogyra* filament attains considerable length?
  - Planaria* gets cut into two pieces?
80. (a) Give reason : Regeneration is not the same as Reproduction.  
 (b) State the mode of a asexual reproduction in *Plasmodium*
81. (a) Surgical methods can be used to create a block in the reproductive system for contraceptive purposes. Name such parts where blocks are created in : (i) males (ii) females  
 (b) State any two reasons for using contraceptive devices.
82. (a) What is vegetative propagation?  
 (b) Write any two advantages of practising this method.
83. (a) Out of the following plants which two plants are reproduced by vegetative propagation? jasmine, wheat, mustard, banana  
 (b) List any one advantage of practising this kind of propagation.
84. (a) Identify the asexual method of reproduction in each of the following organisms : (i) rose  
 (ii) yeast (iii) *planaria*  
 (b) What is fragmentation? Name a multicellular organism which reproduces by this method.
85. (a) How do the oral pills function as contraceptives?  
 (b) The use of these pills may be harmful. Why?
86. (a) Explain the terms : (i) implantation (ii) placenta  
 (b) What is the average duration of human pregnancy?
87. (a) Why do testes located in scrotum outside the abdominal cavity?  
 (b) What will happen to ovary and ovule after fertilization in angiospermic plants.
88. In a bisexual flower inspite of the young stamens being removed artificially, the flower produces fruit. Give reasons.  
 (a) Name the parts of the flower which ripens to form fruit and seed?  
 (b) In the following diagram label A and B.

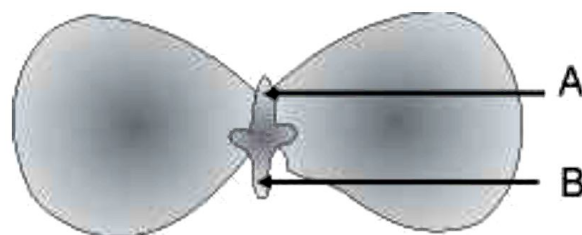

**ASSIGNMENT QUESTIONS SET – 3**  
**CHAPTER – 8**  
**HOW DO ORGANISMS REPRODUCE?**

1. In the list of organisms given below, those that reproduce by the asexual method are
  - (i) banana
  - (ii) dog
  - (iii) yeast
  - (iv) Amoeba
2. In a flower, the parts that produce male and female gametes (germ cells) are
  - (a) stamen and anther
  - (b) filament and stigma
  - (c) anther and ovary
  - (d) stamen and style
3. Which of the following is the correct sequence of events of sexual reproduction in a flower?
  - (a) pollination, fertilisation, seedling, embryo
  - (b) seedling, embryo, fertilisation, pollination
  - (c) pollination, fertilisation, embryo, seedling
  - (d) embryo, seedling, pollination, fertilisation
4. Offspring formed by asexual method of reproduction have greater similarity among themselves because
  - (i) asexual reproduction involves only one parent
  - (ii) asexual reproduction does not involve gametes
  - (iii) asexual reproduction occurs before sexual reproduction
  - (iv) asexual reproduction occurs after sexual reproduction
  - (a) (i) and (ii) (b) (i) and (iii)
  - (c) (ii) and (iv) (d) (iii) and (iv)
5. Characters transmitted from parents to offspring are present in
  - (a) cytoplasm
  - (b) ribosome
  - (c) golgi bodies
  - (d) genes
6. Characters that are transmitted from parents to offspring during reproduction show
  - (a) only similarities with parents

- (b) only variations with parents
  - (c) both similarities and variations with parents
  - (d) neither similarities nor variations
7. A feature of reproduction that is common to *Amoeba*, *Spirogyra* and Yeast is that
- (a) they reproduce asexually
  - (b) they are all unicellular
  - (c) they reproduce only sexually
  - (d) they are all multicellular
8. In *Spirogyra*, asexual reproduction takes place by
- (a) breaking up of filaments into smaller bits
  - (b) division of a cell into two cells
  - (c) division of a cell into many cells
  - (d) formation of young cells from older cells.
9. The ability of a cell to divide into several cells during reproduction in *Plasmodium* is called
- (a) budding
  - (b) reduction division
  - (c) binary fission
  - (d) multiple fission
10. The correct sequence of reproductive stages seen in flowering plants is
- (a) gametes, zygote, embryo, seedling
  - (b) zygote, gametes, embryo, seedling
  - (c) seedling, embryo, zygote, gametes
  - (d) gametes, embryo, zygote, seedling
11. The number of chromosomes in parents and offsprings of a particular species remains constant due to
- (a) doubling of chromosomes after zygote formation
  - (b) halving of chromosomes during gamete formation
  - (c) doubling of chromosomes after gamete formation
  - (d) halving of chromosomes after gamete formation
12. In *Rhizopus*, tubular thread-like structures bearing sporangia at their tips are called
- (a) filaments
  - (b) hyphae
  - (c) rhizoids
  - (d) roots
13. Vegetative propagation refers to formation of new plants from

- (a) stem, roots and flowers
- (b) stem, roots and leaves
- (c) stem, flowers and fruits
- (d) stem, leaves and flowers

**14.** Factors responsible for the rapid spread of bread mould on slices of bread are

- (i) large number of spores
- (ii) availability of moisture and nutrients in bread
- (iii) presence of tubular branched hyphae
- (iv) formation of round shaped sporangia

- (a) (i) and (iii) (b) (ii) and (iv)
- (c) (i) and (ii) (d) (iii) and (iv)

**15.** Length of pollen tube depends on the distance between

- (a) pollen grain and upper surface of stigma
- (b) pollen grain on upper surface of stigma and ovule
- (c) pollen grain in anther and upper surface of stigma
- (d) upper surface of stigma and lower part of style

**16.** Which of the following statements are true for flowers?

- (i) Flowers are always bisexual
- (ii) They are the sexual reproductive organs
- (iii) They are produced in all groups of plants
- (iv) After fertilisation they give rise to fruits

- (a) (i) and (iv) (b) (ii) and (iii)
- (c) (i) and (iii) (d) (ii) and (iv)

**17.** Which among the following statements are true for unisexual flowers?

- (i) They possess both stamen and pistil
- (ii) They possess either stamen or pistil
- (iii) They exhibit cross pollination
- (iv) Unisexual flowers possessing only stamens cannot produce fruits

- (a) (i) and (iv) (b) (ii), (iii) and (iv)
- (c) (iii) and (iv) (d) (i), (iii) and (iv)

**18.** Which among the following statements are true for sexual reproduction in flowering plants?

- (i) It requires two types of gametes
- (ii) Fertilisation is a compulsory event
- (iii) It always results in formation of zygote



- (iv) Offspring formed are clones
- (a) (i) and (iv) (b) (i), (ii) and (iv)
- (c) (i), (ii) and (iii) (d) (i), (ii) and (iv)

**19.** In the below Figure, the parts A, B and C are sequentially

- (a) cotyledon, plumule and radicle
- (b) plumule, radicle and cotyledon
- (c) plumule, cotyledon and radicle
- (d) radicle, cotyledon and plumule

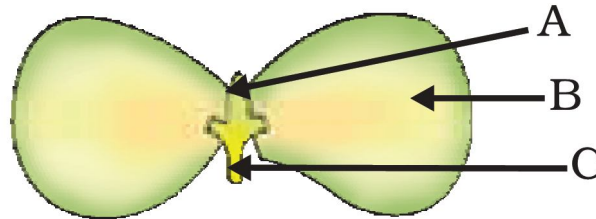

**20.** Offspring formed as a result of sexual reproduction exhibit more variations because

- (a) sexual reproduction is a lengthy process
- (b) genetic material comes from two parents of the same species
- (c) genetic material comes from two parents of different species
- (d) genetic material comes from many parents

**21.** Reproduction is essential for living organisms in order to

- (a) keep the individual organism alive
- (b) fulfill their energy requirement
- (c) maintain growth
- (d) continue the species generation after generation

**22.** During adolescence, several changes occur in the human body. Mark one change associated with sexual maturation in boys

- (a) loss of milk teeth
- (b) increase in height
- (c) cracking of voice
- (d) weight gain

**23.** In human females, an event that reflects onset of reproductive phase is

- (a) growth of body
- (b) changes in hair pattern
- (c) change in voice
- (d) menstruation

**24.** In human males, the testes lie in the scrotum, because it helps in the

- (a) process of mating
  - (b) formation of sperm
  - (c) easy transfer of gametes
  - (d) all the above
- 25.** Which among the following is not the function of testes at puberty?
- (i) formation of germ cells
  - (ii) secretion of testosterone
  - (iii) development of placenta
  - (iv) secretion of estrogen
- (a) (i) and (ii) (b) (ii) and (iii)  
(c) (iii) and (iv) (d) (i) and (iv)
- 26.** The correct sequence of organs in the male reproductive system for transport of sperms is
- (a) testis → □ vasdeferens → □ urethra
  - (b) testis → □ ureter → □ urethra
  - (c) testis → □ urethra → □ ureter
  - (d) testis → □ vasdeferens → □ ureter
- 27.** Which among the following diseases is not sexually transmitted?
- (a) Syphilis
  - (b) Hepatitis
  - (c) HIV - AIDS
  - (d) Gonorrhoea
- 28.** In a bisexual flower inspite of the young stamens being removed artificially, the flower produces fruit. Provide a suitable explanation for the above situation.
- 29.** Can you consider cell division as a type of reproduction in unicellular organism? Give one reason.
- 30.** What is a clone? Why do offsprings formed by asexual reproduction exhibit remarkable similarity?
- 31.** Explain how, offspring and parents of organisms reproducing sexually have the same number of chromosomes?
- 32.** Colonies of yeast fail to multiply in water, but multiply in sugar solution. Give one reason for this.
- 33.** Why does bread mould grow profusely on a moist slice of bread rather than on a dry slice of bread?
- 34.** Give two reasons for the appearance of variations among the progeny formed by sexual reproduction.

35. Would a *Planaria* cut vertically into two halves regenerate into two individuals? Complete the below Figure D and E by indicating the regenerated regions.

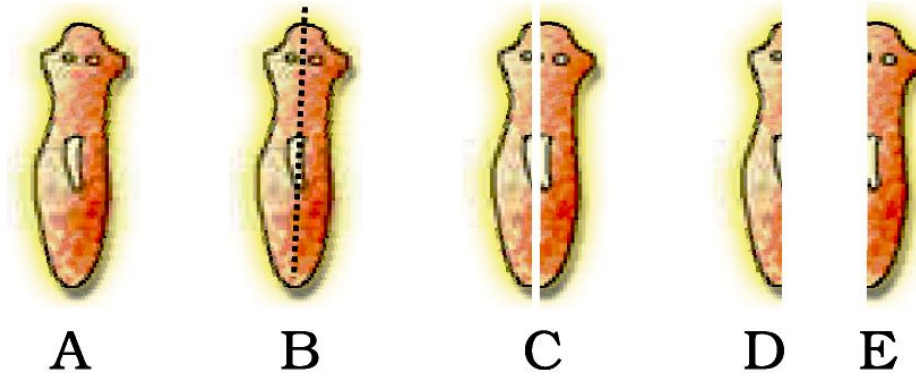

36. From the internet, gather information about the chromosome numbers of five animals and five plants. Correlate the number with the size of organism and answer the following questions.
- Do larger organisms have more number of chromosomes/cells?
  - Can organism with fewer chromosomes reproduce more easily than organisms with more number of chromosomes?
  - More the number of chromosomes/cells greater is the DNA content. Justify.
37. In tobacco plant, the male gametes have twenty four chromosomes. What is the number of chromosomes in the female gamete? What is the number of chromosomes in the zygote?
38. Why cannot fertilisation take place in flowers if pollination does not occur?
39. Is the chromosome number of zygote, embryonal cells and adult of a particular organism always constant? How is the constancy maintained in these three stages?
40. Where is the zygote located in the flower after fertilization?
41. Reproduction is linked to stability of population of a species. Justify the statement.
42. How are general growth and sexual maturation different from each other?
43. Trace the path of sperm during ejaculation and mention the gland and their functions associated with the male reproductive system.
44. What changes are observed in the uterus if fertilisation does not occur?
45. What changes are observed in the uterus subsequent to implantation of young embryo?
46. What are the benefits of using mechanical barriers during sexual act?
47. In the given below Figure label the parts and mention their functions
- Production of egg
  - Site of fertilisation
  - Site of implantation
  - Entry of the sperms

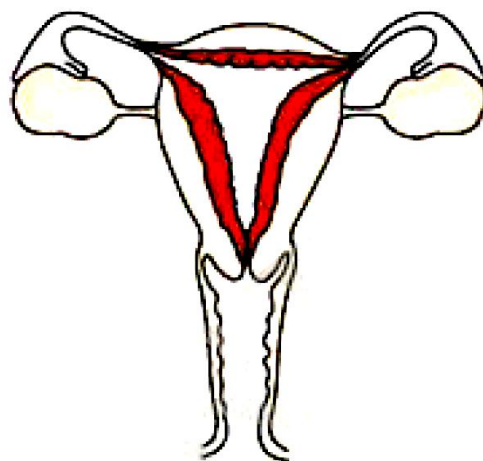

48. What would be the ratio of chromosome number between an egg and its zygote? How is the sperm genetically different from the egg?
  49. Why are budding, fragmentation and regeneration all considered as asexual types of reproduction? With neat diagrams explain the process of regeneration in *Planaria*.
  50. Write two points of difference between asexual and sexual types of reproduction. Describe why variations are observed in the offspring formed by sexual reproduction.
  51. Distinguish between pollination and fertilisation. Mention the site and product of fertilisation in a flower.
  52. Draw a neat, labelled diagram of a pistil showing pollen tube growth and its entry into the ovule.
  53. Distinguish between a gamete and zygote. Explain their roles in sexual reproduction.
  54. Draw the diagram of a flower and label the four whorls. Write the names of gamete producing organs in the flower.
  55. What is placenta? Mention its role during pregnancy?
  56. What are various ways to avoid pregnancy? Elaborate any one method.
  57. What are placenta ? Explain its structure and function.
  58. How does fertilisation take place? Fertilisation occurs once in a month. Comment.
  59. Reproduction is essentially a phenomenon that is not for survival of an individual but for the stability of a species. Justify.
  60. Describe sexually transmitted diseases and mention the ways to prevent them.
- .....

## CHAPTER – 9

### HEREDITY AND EVOLUTION

#### **ACCUMULATION OF VARIATION DURING REPRODUCTION**

By virtue of being the progeny of the parent, the progeny individual, need not just be the replica of what its parents are. (Inheritance of characters from the parents to the progeny (i.e. , Heredity) ensures the passing of the parental characters to the progeny). The difference or change in the characteristics between the individuals is called Variation. Human population shows a great deal of variation.

Inheritance from the previous generation provides both a common basic body design, and subtle changes in it, for the next generation. The second generation will have differences that they inherit from the first generation, as well as newly created differences.

The below figures shows Creation of diversity over succeeding generations. The original organism at the top will give rise to, say, two individuals, similar in body design, but with subtle differences. Each of them, in turn, will give rise to two individuals in the next generation. Each of the four individuals in the bottom row will be different from each other. While some of these differences will be unique, others will be inherited from their respective parents, who were different from each other.

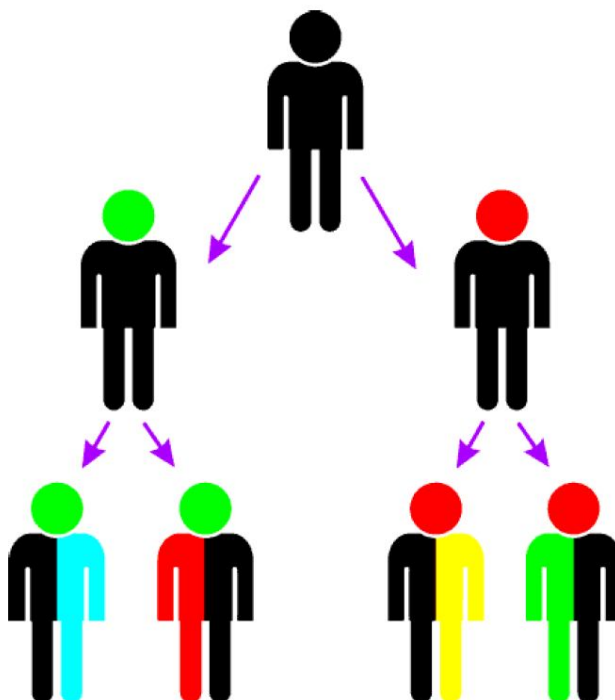

#### **INTEXT QUESTIONS PAGE NO. 143**

**Q1. If a trait A exists in 10% of a population of an asexually reproducing species and a trait B exists in 60% of the same population, which trait is likely to have arisen earlier?**

**Ans:** Trait 'B'.

Percentage of any gene in a population increases from generation to generation.

**Q2. How does the creation of variations in a species promote survival?**

**Ans:**

During reproduction (also inaccuracies in DNA replications), many variations occur in the offspring. Some individuals have more favourable variations than the other. Such individuals

survive and pass these variations on their progeny. For example, let us consider the population of beetles. Due to certain conditions, a colour arised during reproduction so that one beetle is green in colour (instead of red). This beetle can pass this colour to its progeny. Crows now cannot see these green-coloured beetles on green leaves and hence, their population become more than that of red-coloured beetles.

## HEREDITY

The progeny produced through the reproductive process is similar to its parents, in body design, function etc., The rules of heredity determine the process by which the traits and the characteristics are relatively inherited.

*“The inheritance of characteristics through generation is called heredity”*

The inheritable characteristics may be morphological/anatomical/physiological/ reproductive and are also known as traits.

If we take a very close look at the rules of inheritance, both father and mother contribute equal amount of genetic material to the child. This means that each trait can be influenced by both paternal and maternal genetic material – i.e, DNA.

## RULES FOR THE INHERITANCE OF TRAITS – MENDEL’S CONTRIBUTIONS

Gregor Johann Mendel (1822-1884) worked out the first ever scientific experimental study on heredity.

Mendel, an Austrian Augustinian monk observed variations in the characteristics of garden pea plant (*Pisum sativum*) which he had cultivated in his monastery garden. Mendel was curious to find out the results of crossing of pea plants with the variation in traits. The visible contrasting characters that Mendel observed in the garden pea plants were given below:

### Seed shape - Round/Wrinkled

Character Dominant trait



Seed shape

Round

Recessive trait



Wrinkled

### Seed colour - Yellow/Green

Character Dominant trait



Seed colour

Yellow

Recessive trait



Green

**Flower colour - Violet / White**

Character Dominant trait

Flower colour



Violet

Recessive trait

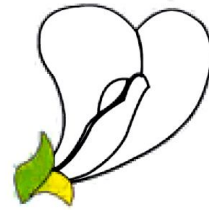

White

**Pod shape - Full / Constricted**

Character Dominant trait

Pod shape



Full

Recessive trait



Constricted

**Pod colour - Green / Yellow**

Character Dominant trait

Pod colour



Green

Recessive trait



Yellow

**Flower position - Axillary / Terminal**

Character Dominant trait

Flower  
Position

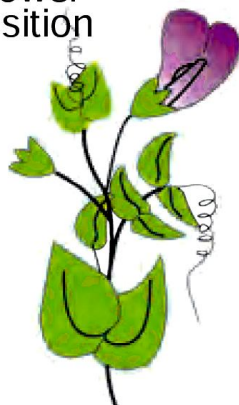

Axial

Recessive trait



Terminal

## Stem height - Tall / Dwarf

Character Dominant trait

Recessive trait

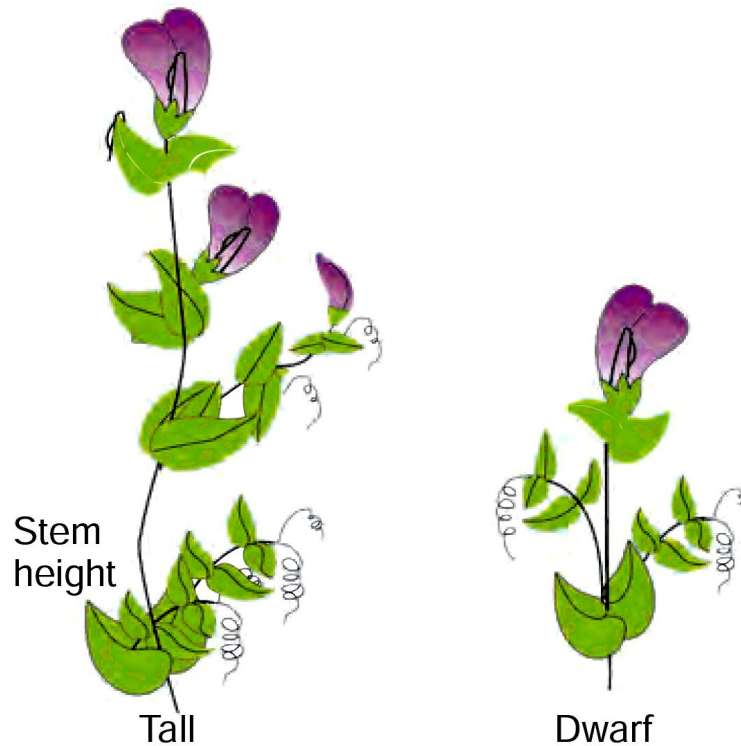

## MENDEL'S MONOHYBRID CROSS

Mendel selected the garden pea plant, *Pisum sativum* for his experiments. He selected tall and dwarf plants and allowed them to grow naturally. As pea plants produce seeds only by self pollination, he observed that tall plants produced always tall plants generation after generation under natural condition. Similarly, dwarf plants produced always dwarf plants generation after generation. Hence, he termed the tall and dwarf plants as wild types or pure breeding varieties.

Then he crossed a tall plant with a dwarf plant, produced progeny and calculated the percentage of tallness and dwarfness in subsequent generations. When a pure breeding tall plant was crossed with a pure breeding dwarf plant, all plants were tall in the first filial generation (F1) i.e., there was not any medium height plants or dwarf plants.

This means that only one of the parental traits were seen and not the mixture of the two. When such a F1 tall plant was allowed to have self pollination, both the tall and dwarf plants appeared in second filial generation (F2). in the ratio of 3:1.

This indicates that both tallness and dwarfness were inherited in the F1 plants but only tallness trait was expressed.

The first experiment of Mendel considering the inheritance of a single trait (Height of the plant Tall/Dwarf) is called Monohybrid Cross.

Expression of morphological characters as tall or dwarf plant, violet or white flower is called Phenotype.

The expression of gene (or Chromosomal make up) of an individual for a particular trait is called Genotype.



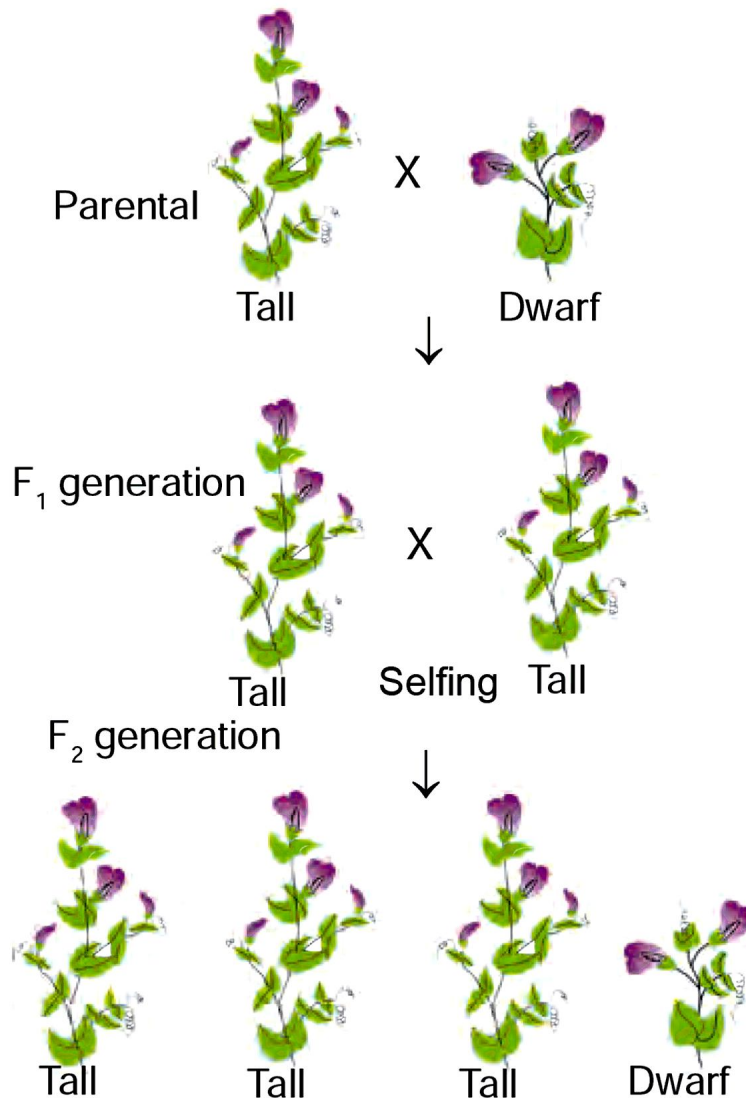

*Diagrammatic representation of Monohybrid cross*

#### POINTS TO REMEMBER:

- ☞ **Heredity:** The passing of traits from the parents to offspring is called heredity. **Genotype:** The complete set of genes in an organism's genome is called genotype.
- ☞ **Phenotype:** The observable characters in an organism make the phenotype. Phenotype is a result of genotype's interaction with the environment. Due to this reason, many phenotypes are not inheritable.
- ☞ **Acquired Traits:** Traits; which are acquired due to interaction with the environment; are called acquired traits. Acquired traits are not inheritable.
- ☞ **Inheritable Traits:** Traits; which can be expressed in subsequent generations; are called inheritable traits. Such traits bring a change in the genotype of the organism and hence become inheritable.

#### MENDEL'S FIRST LAW

Law of Segregation: Every individual possesses a pair of alleles for a particular trait. During gamete formation, a gamete receives only one trait from the alleles. A particular trait can be dominant or recessive in a particular generation.

## DIHYBRID CROSS

The cross in which two pairs of characters are studied is called dihybrid cross. In his second experiment, Mendel used dihybrid cross.

Let us take example between plants with round and green seeds and those with wrinkled and yellow seeds. The genotype of round and green seeds is shown by  $RRyy$  and that of wrinkled and yellow seeds is shown by  $rrYY$ . In the  $F_1$  generation, all plants produced round and yellow seeds; which means that wrinkled texture was the recessive character and so was the green colour of seeds. When plants of  $F_1$  generation were allowed to self pollinate; it was observed that most of the plants in  $F_2$  generation produced round and yellow seeds. Some plants produces round green seeds, some produced wrinkled yellow seeds and some produced wrinkled green seeds. The ratio was  $9 : 3 : 3 : 1$ ; as shown in the below figure.

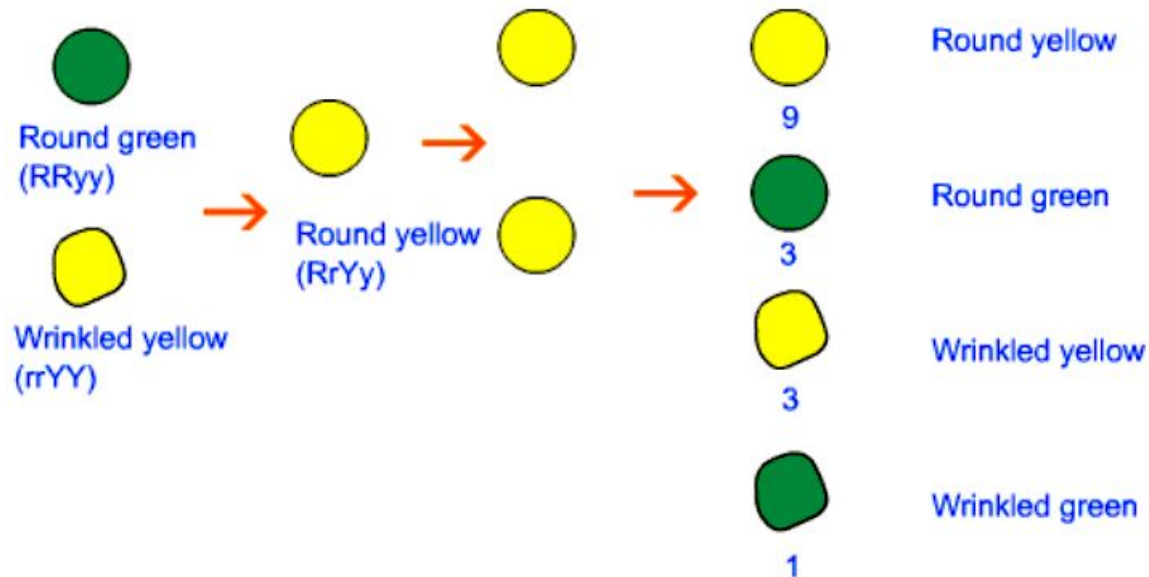

## MENDEL'S SECOND LAW:

Law of Independent Assortment: Alleles of different characters separate independent from each other during gamete formation.

In the above example; alleles of texture were assorted independently from those of seed colour.

## SEX DETERMINATION IN HUMANS:

Somatic cells in human beings contain 23 pairs of chromosomes. Out of them the 23rd pair is composed of different types of chromosomes which are named as X and Y chromosomes. The 23rd pair contains one X and one Y chromosome in a male. On the other hand, the 23rd pair in a female contains X chromosomes. This means that all the eggs would have X chromosome as the 23rd chromosome, while a sperm may have either X or Y chromosome as the 23rd chromosome. When a sperm with X chromosome fertilizes the egg, the resulting zygote would develop into a female child. When a sperm with Y chromosome fertilizes the egg, the resulting zygote would develop into a male child.

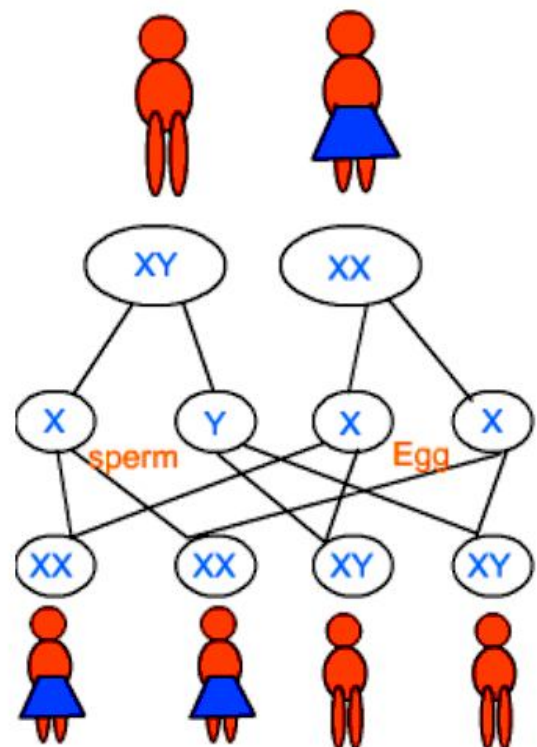

**INTEXT QUESTIONS PAGE NO. 147**

**Q1. How do Mendel’s experiments show that traits may be dominant or recessive?**

**Ans:**

Mendel crossed a pure tall pea plant (TT) with pure dwarf pea plant (tt) and observed that all the progeny were hybrid tall (Tt), *i.e.*, only one of the trait was able to express itself in the F<sub>1</sub> generation, which is the **dominant trait**. The other trait called the **recessive trait** remain suppressed.

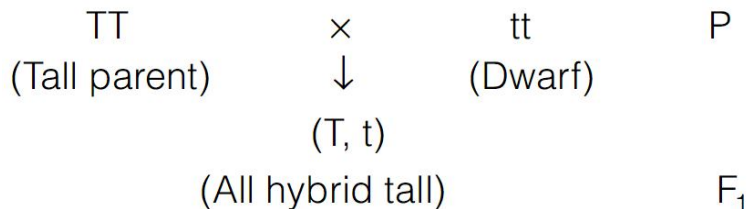

However, when he self crossed plants of F<sub>1</sub> generation, he observed that **one fourth** of the plants were dwarf and three fourth were tall.

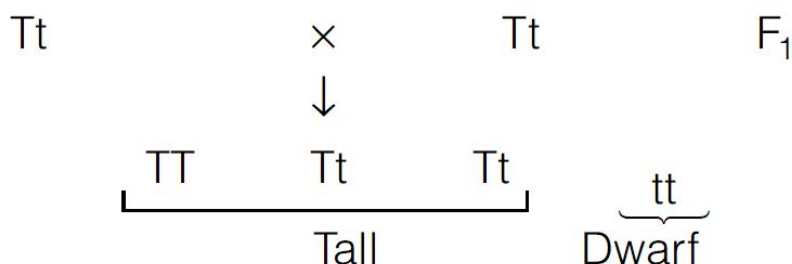

**Q2. How do Mendel’s experiments show that traits are inherited independently?**

**Ans:** Please refer the above section **DIHYBRID CROSS**

**Q3. A man with blood group A marries a woman with blood group O and their daughter has blood group O. Is this information enough to tell you which of the traits – blood group A or O – is dominant? Why or why not?**

**Ans:**

This shows that blood group ‘O’ is dominant and ‘A’ is recessive because blood group ‘O’ was able to express itself in heterozygous condition, due to which the progeny had blood group ‘O’.

**Q4. How is the sex of the child determined in human beings?**

**Ans:**

Somatic cells in human beings contain 23 pairs of chromosomes. Out of them the 23rd pair is composed of different types of chromosomes which are named as X and Y chromosomes. The 23rd pair contains one X and one Y chromosome in a male. On the other hand, the 23rd pair in a female contains X chromosomes. This means that all the eggs would have X chromosome as the 23rd chromosome, while a sperm may have either X or Y chromosome as the 23rd chromosome. When a sperm with X chromosome fertilizes the egg, the resulting zygote would develop into a female child. When a sperm with Y chromosome fertilizes the egg, the resulting zygote would develop into a male child.

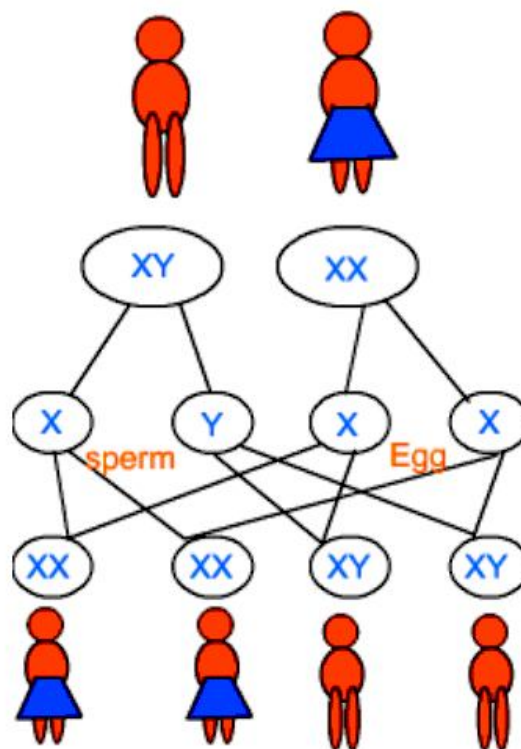

## EVOLUTION

The change in inherited traits in biological population over subsequent generations is called evolution. Scientists have proven that life evolved in the form of simple unicellular organisms on this earth; and all the organisms which are present today have evolved from a common ancestor. The idea of evolution is based on the premise of a common ancestry.

Let us consider a group of twelve beetles. They live in bushes on green leaves. Their population will grow by sexual reproduction. So they were able to generate variations in population. Let us assume crows eat these red beetles. If the crows eat more Red beetles their population slowly reduced.

Let us think of different situations.

### Situation-1:

In this situation a colour variation arises during reproduction. So that there appears one beetle that is green in colour instead of red.

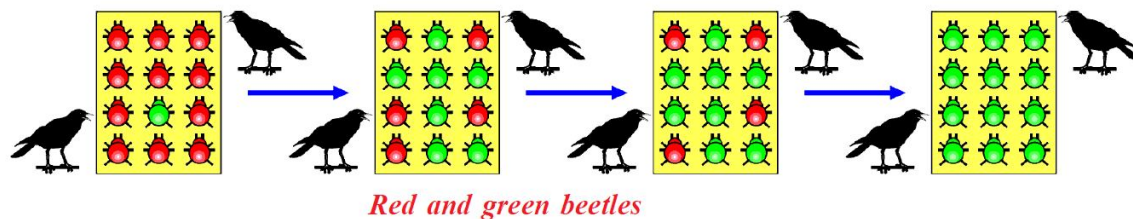

More over this green coloured beetle passes its colour to its off spring (Progeny). So that all its progeny are green. Crows cannot see the green coloured beetles on green leaves of the bushes and therefore crows cannot eat them. But crows can see the red beetles and eat them. As a result there are more and more green beetles than red ones which decrease in their number.

The variation of colour in beetle 'green' gave a survival advantage to 'green beetles' than red beetles. In other words it was naturally selected.

We can see that the 'natural selection' was exerted by the crows. The more crows there are, the more red beetles would be eaten and the more number of green beetles in the population would be. Thus the natural selection is directing evolution in the beetle population. It results in adaptation in the beetle population to fit in their environment better.

### Situation-2:

In this situation a colour variation occurs again in its progeny during reproduction, but now it results in 'Blue' colour beetles instead of 'red' colour beetle. This blue colour beetle can pass its colour to its progeny. So that all its progeny are blue.

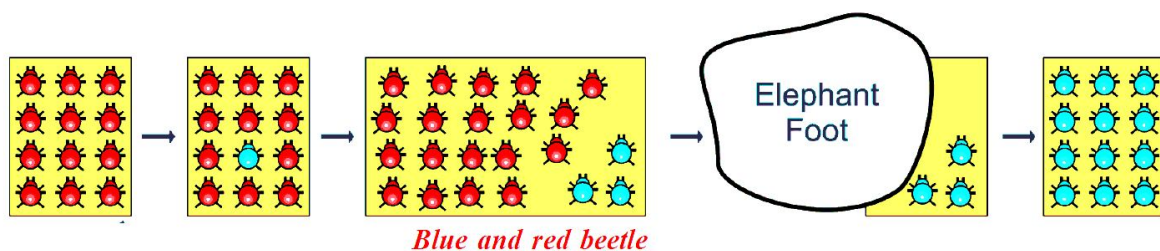

Crows can see blue coloured beetles on the green leaves of the bushes and the red ones as well. And therefore crows can eat both red and blue coloured beetles. In this case there is no survival advantage for blue coloured beetles as we have seen in case of green coloured beetles.

What happens initially in the population, there are a few blue beetles, but most are red. Imagine at this point an elephant comes by and stamps on the bushes where the beetles live. This kills most of the beetles. By chance the few beetles survived are mostly blue. Again the beetle population slowly increases. But in the beetle population most of them are in blue colour.

Thus sometimes accidents may also result in changes in certain characters of the a population. Characters as we know are governed by genes. Thus there is change in the frequency of genes

in small populations. This is known as “Genetic drift”, which provides diversity in the population.

### **Situation-3:**

In this case beetles population is increasing, but suddenly bushes were affected by a plant disease in which leaf material were destroyed or in which leaves are affected by this beetles got less food material. So beetles are poorly nourished. So the weight of beetles decrease but no changes take place in their genetic material (DNA). After a few years the plant disease are eliminated. Bushes are healthy with plenty of leaves.

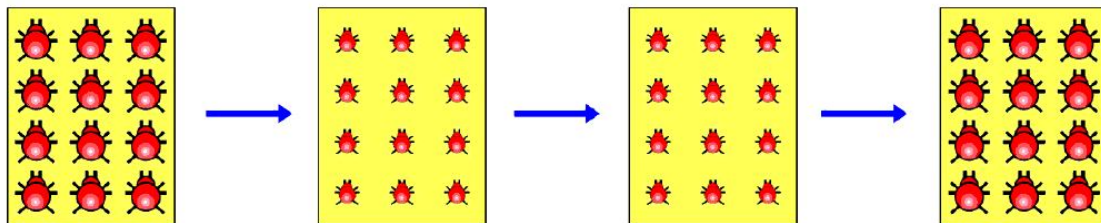

*Poorly nourished beetles*

## **ACQUIRED AND INHERITED CHARACTERS AND EVOLUTION**

The germ cells of sexually reproducing population are formed in specialised reproductive tissue. If the weight of the beetles is reduced because of starvation, that will not change the DNA of the germ cells. Therefore, low weight is not a trait that can be inherited by progeny of a starving beetle. Therefore even if some generations of beetles lose their weight because of starvation, that is not an example of evolution, since the change is not inherited over generations. Change in non reproductive tissues cannot be passed on to the DNA of the germ cells. Therefore the experiences of an individual during its lifetime cannot be passed on to its progeny, and cannot direct evolution.

### **DARWIN’S THEORY OF EVOLUTION:**

Charles Darwin wrote his famous book ‘Origin of Species’. He threw new insights on evolution of species. Some salient points of Darwin’s theory are as follows:

#### **Organisms have unlimited capacity to reproduce:**

Organisms can reproduce offspring at a fast pace. This is necessary for survival, because a higher number of offspring ensures that at least some of them could survive. Each organism has to struggle for its day to day survival. For example; a frog lays thousands of eggs at one go. The spawn is released in water and it is left to fend for itself. Most of the eggs are either washed away or are eaten by predators. However, some portion of eggs from the spawn develops into tadpoles. Once again, many tadpoles are eaten up by predators; leaving a few which develop into adults. It is evident, that a large number of eggs is needed to ensure that at least some of them develop into adults.

#### **Natural Selection:**

Different individuals of a particular species have different traits. Those with more suitable traits are selected by the nature. Each organism needs a particular trait for finding food and finding a mate. Those with better traits are finally able to pass on their traits to the next generation.

#### **Survival of the Fittest:**

Those organisms which are the fittest are able to survive, while others perish. That is how many species become extinct and some species continue to evolve over a period of time.

### **MOLECULAR ORIGIN OF LIFE:**

Stanley L. Miller and Harold C. Urey, conducted the Miller-Urey experiment in 1953 to demonstrate how the life would have originated on the earth. They created an environment in laboratory which mimicked the environment of earth as it was during the time of origin of life. Water, methane, ammonia and hydrogen were used in that experiment. The liquid was heated to initiate evaporation and electrodes were used to create electric discharge. At the end of two weeks, some organic molecules were formed in the setup. Some amino acids and sugar were also formed. This proved the hypothesis of J. B. S. Haldane that life originated from inorganic raw materials.

### **INTEXT QUESTIONS PAGE NO. 150**

**Q1. What are the different ways in which individuals with a particular trait may increase in a population?**

**Ans:**

**There are different ways in which an individual with a particular trait may increase in a population**

- ☞ When a colour variation arise during reproduction, it can pass the colour on to its progeny which may protect them from prey.
- ☞ Accidents in small population can change the frequency of some genes in a population even if they give no survival advantage.
- ☞ Poor nourishment may reduce the population of individuals but when nourishment conditions improve the population starts increasing again.

Thus, the maturation, adaptation to environment and natural selection may increase a particular trait in a population.

**Q2. Why are traits acquired during the life-time of an individual not inherited?**

**Ans:**

Traits acquired during the life-time of an individual just enable an individual to adapt itself to the surrounding and do not change the genetic make up of the organism. Only those variations are inherited, which come into the germ cell of the organism.

**Q3. Why are the small numbers of surviving tigers a cause of worry from the point of view of genetics?**

**Ans:**

Small numbers of surviving tigers are a cause of worry from the point of genetics because their loss would cause a loss of gene pool, *i.e.*, many genes will be eliminated from a gene pool.

### **SPECIATION**

The process of origin of a new species is called speciation. A species is a group of organisms in which most of the characters are similar and members of a species are able to breed among themselves. Speciation can happen if two groups of the same species are somehow prevented from interbreeding for several generations. This can happen because of geographical segregation or because of some genetic changes. Evolution of new species, because of geographical segregation is called genetic drift.

### **INTEXT QUESTIONS PAGE NO. 151**

**Q1. What factors could lead to the rise of a new species?**

**Ans:**

Genetic drift and natural selection could lead to rise of a new species.

**Q2. Will geographical isolation be a major factor in the speciation of a selfpollinating plant species? Why or why not?**

**Ans:**

No, geographical isolation is not a major factor in the formation of new species of self-pollinated plants. This is because self-pollinated plants receive pollen grains from the same flower or another flower on the same plant and its distance from other plants hardly affects its reproduction. Moreover, self-pollinated plants rarely, show variations in characters.

**Q3. Will geographical isolation be a major factor in the speciation of an organism that reproduces asexually? Why or why not?**

**Ans:**

No, because asexual reproduction involves only a single parent. So, the geographical isolation do not affect its reproduction cycle. Moreover, asexually reproducing organisms rarely show any variations in characters.

**EXERCISE QUESTIONS PAGE NO. 159**

**Q1. A Mendelian experiment consisted of breeding tall pea plants bearing violet flowers with short pea plants bearing white flowers. The progeny all bore violet flowers, but almost half of them were short. This suggests that the genetic make-up of the tall parent can be depicted as**

- (a) TTWW
- (b) TTww
- (c) TtWW
- (d) TtWw

**Ans:** (c) TtWW.

Parent with genotype TtWW produce two types of gametes TW and tW, while the other with genotype ttww produce only one type of gamete 'tw'

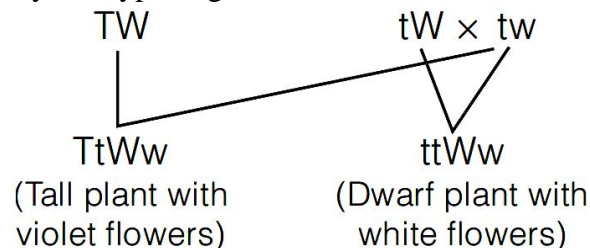

**Q2. An example of homologous organs is**

- (a) our arm and a dog's fore-leg.
- (b) our teeth and an elephant's tusks.
- (c) potato and runners of grass.
- (d) all of the above.

**Ans:** (a)

Our arms and a dog's fore-leg is the example of homologous organs.

**Q3. In evolutionary terms, we have more in common with**

- (a) a Chinese school-boy.
- (b) a chimpanzee.
- (c) a spider.
- (d) a bacterium.

**Ans:** (a)

A chinese school-boy because both have almost similar DNA.

**Q4. A study found that children with light-coloured eyes are likely to have parents with light-coloured eyes. On this basis, can we say anything about whether the light eye colour trait is dominant or recessive? Why or why not?**

**Ans:**

From this study, we cannot make any inference whether light eye colour trait is recessive or dominant, because as both the parents have light colour eye, all the children will definitely have light colour eye (though certain variations may occur.)

**Q5. How are the areas of study – evolution and classification – interlinked?**

**Ans:**

The study of classification of various organisms give us idea about the evolutionary history of an organisms. Organism which have certain similar characteristics are placed in one group. It can be thus concluded that the organisms placed in one group may have evolved from common ancestors and may have common evolutionary history.

**Q6. Explain the terms analogous and homologous organs with examples.**

**Ans:**

**Homologous organs** have the same basic structure and origin but perform different functions. For example, the forelimb of a frog, a bird and a man have the same basic design of bones, but they perform different functions (frog use them to jump, birds use them to fly and man use them to grasp).

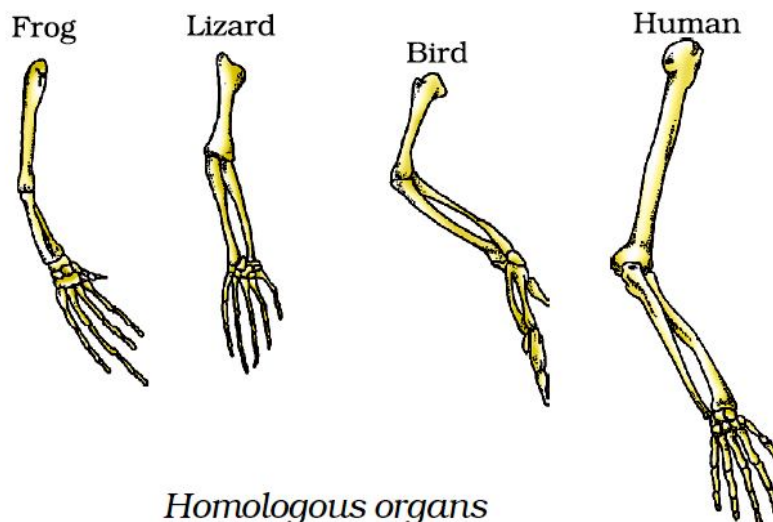

*Homologous organs*

**Analogous organs** have different basic structure and origin but have similar appearance and perform similar functions, *e.g.*, wings of insects and wings of birds have different basic structure as the wings of insect is a fold of membrane and wings of a bird are modified forelimbs.

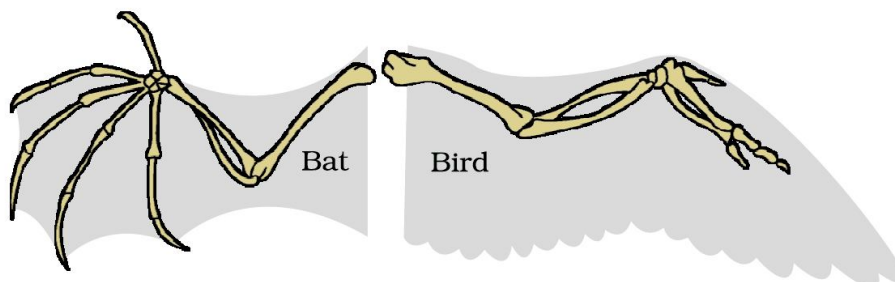

*Analogous organs – The wing of a bat and the wing of a bird*

**Q7. Outline a project which aims to find the dominant coat colour in dogs.**



**Ans:**

Coat colour 'T' is a dominant factor and white colour 't' is recessive.

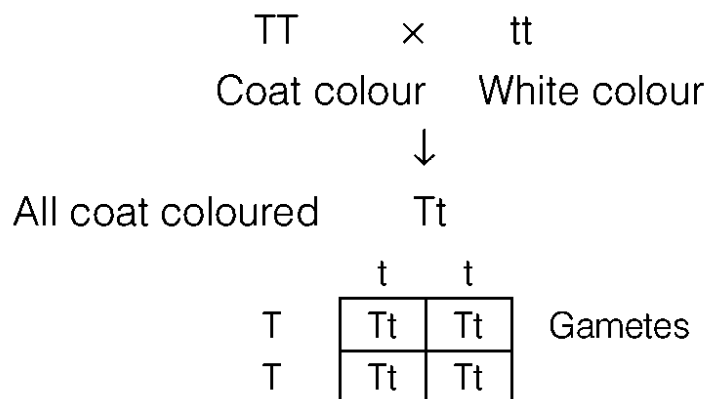

**Q8. Explain the importance of fossils in deciding evolutionary relationships.**

**Ans:**

The preserved remains of animals or plants or other organisms from the distant past are called fossils.

- ☞ Fossils provide the evidence that the present animal have originated from previously existing ones through the process of continuous evolution.
- ☞ Fossils can be used to reconstruct evolutionary history of an organism. The distribution pattern of fossils shows that the ancient fossils present in the bottom rocks are simple, while the most recent fossils found in the upper strata are more highly evolved. It means fossils form and become more and more complex as we proceed from earliest to recent rocks.
- ☞ It gives us an idea of time in history when different species were formed or became extinct.
- ☞ Fossil also help to trace the evolutionary history of some animals.
- ☞ Fossils also indicate connecting link between the two groups of organisms.
- ☞ For example, *Archaeopteryx* is a connecting link between reptiles and birds.

**Q9. What evidence do we have for the origin of life from inanimate matter?**

**Ans:**

Life must have developed from the simple inorganic molecules which were present on Earth soon after it was formed. Conditions on Earth could have given rise to more complex organic molecules that were necessary for life. The first primitive organism would have arisen from further chemical synthesis. The organic molecules were assembled in an atmosphere similar to that thought to exist on early Earth over water. This was maintained at a temperature just below 100°C and sparks were passed through the mixture of gases to stimulate lightning. At the end, carbon was converted to simple compounds of carbon including amino acids which make up protein molecules. This experiment set up demonstrates that life originated from inorganic molecules.

**Q10. Explain how sexual reproduction gives rise to more viable variations than asexual reproduction. How does this affect the evolution of those organisms that reproduce sexually?**

**Ans:**

Sexual reproduction involves fusion of gametes. The offsprings show variations from their parents due to crossing over and exchange of gene segments. They are not carbon copies of their parents, due to recombination of parental genes and produce better offsprings. Also, due to environmental factors certain favourable variations are also produced. Due to production of variations, sexually reproducing animals show very quick evolution.

Whereas in asexual reproduction, organisms raised are the exact copies of parents. They rarely show any variation.

**Q11. How is the equal genetic contribution of male and female parents ensured in the progeny?**

**Ans:**

The male and female reproductive cells divide by meiosis to form haploid gametes. These gametes have equal genetic material. The zygote is formed by the fusion of male and female gamete, *i.e.*, it has equal genetic contribution from male and female parents. The individual is developed from the zygote these after.

**Q12. Only variations that confer an advantage to an individual organism will survive in a population. Do you agree with this statement? Why or why not?**

**Ans:**

All the variations in a species do not have equal chances of surviving in the environment. Depending on the nature of variations different individuals would have different kinds of advantages. Selection of variants by environmental factors forms the basis of evolutionary process. The variations which confer disadvantages to an individual organism will not survive because the environmental factor cannot support this.

.....

**ASSIGNMENT QUESTIONS SET – 1**  
**CHAPTER – 9**  
**HEREDITY AND EVOLUTION**

1. What is heredity?
2. Name the plant on which Mendel performed his experiments?
3. Define variation?
4. Define a gene?
5. Who proposed the theory of inheritance of acquired characters.
6. State one of the evolutionary forces leading to the origin of a new species according to the synthetic theory of evolution.
7. Give an example of a vestigial organ present in human body.
8. What is the evolutionary significance of the fossil Archaeopteryx?
9. Who proposed the double helical model of DNA? Answer: Watson and Crick.
10. Who proposed the theory of natural selection? Answer: Charles Darwin.
11. What is retro virus?
12. What is a genetically modified organism (GMO)?
13. Name any two genetic diseases.
14. Write the expanded form of DNA?
15. What are the components of chromosome?
16. What is a retrovirus?
17. What is sex chromosome?
18. How is sex determined in human beings?
19. What do you understand by evolution?
20. Define homologous organs?
21. Explain Darwin's theory of evolution?
22. Define genetics. What is the contribution of Mendel in this branch of biology?
23. Where are the genes located? What is the chemical nature of gene?
24. During which stage of cell division can chromosome be seen? Write the features of prokaryotic and eukaryotic chromosome.
25. Who provided the evidence of DNA as a genetic material? Write the names of components of DNA?
26. What do you understand by the double helical structure of DNA? Who proposed this structure?
27. Describe the different types of chromosomes.
28. How many types of nitrogenous bases are present in DNA? Name them.

29. How do embryological studies provide evidence for evolution?
30. Define evolution. And Describe the contribution of Lamarck?
31. What are homologous organs? How do they provide evidence in support of evolution?
32. Define the following terms? (i) Vestigial organs (ii) Analogous organs.
33. What are transgenic organisms? Which property of DNA is used as a tool in genetic engineering?
34. Explain how the sex of the child is determined at the time of conception in human beings.
35. One of the examples of two analogous organs can be the wing of parrot and
- Flippers of whale.
  - Foreleg of horse
  - Front leg of frog
  - Wing of housefly
36. Mention the ways by which variant genotypes are produced in organism?
37. In human beings blue eye colour is recessive to brown eye colour. If a brown eyed man has a blue eyed mother then find
- What are the possible genotypes of his father?
  - What is the genotype of the man and his mother?
38. What are fossils? Of what interest are fossils to the evolutionary biologists?
39. Who isolated DNA for the first time from pus cells?
40. Why is DNA called polynucleotide?
41. Name two purine nitrogenous bases found in a DNA molecule.
42. Who put forward the double helical model of DNA?
43. What are the three chemically essential parts of nucleotides constituting a DNA?
44. Guinea pig having black colour when crossed with guinea pig having same colour produced 80 offspring, out of which 60 were black and 20 were white. Now, find out: (a) What is the possible genotype of the guinea pigs?  
(b) Which trait is dominant and which trait is recessive?  
(c) What is this cross called as and what is its phenotypic ratio?
45. Distinguish between acquired and inherited traits giving one example of each.
46. Why did Mendel chosen pea plant for his experiments?
47. Cat's paw, human hand and horse's legs-are these organs homologous or analogous? Give reason
48. Wings of bird and wings of insect-are these organs homologous or analogous? Give one suitable reason to support your answer.
49. Give one difference between eyes and eye spot. Which animal possesses eye spots?

50. Give one difference between artificial selection and natural selection.
51. What is true- humans have evolved from chimpanzees or humans and chimpanzees both have evolved from a common ancestor?
52. What is the mechanism behind the expression of a particular trait? explain briefly.
53. What will happen to the expression of a particular trait if a gene get altered?
54. What are various ways by which genes can enter a population?
55. How will new species arise in case:
- (a) Two sub-populations are separated due to a huge mountain in between them?
  - (b) A small population of individuals gets drifted away from the main land due to sea?
56. Only advantageous variations help in the evolution of an organism giving rise to a new species. Explain with the help of an example.
57. A trait may be inherited, but may not be expressed." Justify this statement with the help of a suitable example.
58. (a). What is genetics?
- (b). Give the common name of plant on which Mendel performed his experiments. (c). What for did Mendel use the term factors and what are these factors called now. (d). What are genes? Where are the genes located?
59. 'It is a matter of chance whether a couple will give birth to a male child or a female child.'" Justify this statement with the help of a flow chart showing the fusion of sex chromosomes.
60. What are homologous organs? How do they provide evidence in support of evolution?
61. Who provided the evidence of DNA as a genetic material? Write the names of components of DNA? How many types of nitrogenous bases are present in DNA? Name them.
62. Name the two homologous structures in vertebrates. Why are they so called? How do such organs help in understanding an evolutionary relationship?
63. Will geographical isolation be a major factor in the speciation of a self-pollination plant species? Why or why not?
64. What are vestigial organs? Name any two vestigial organs in man and name organ which is vestigial in man but not in birds.
65. All dead organisms do not leave their fossil records, but in some cases their fossils are formed. How do these fossils records form a direct evidence of past happenings?
66. Evolution is a process in which simple life forms change into complex life forms by gradual changes. But, there is a difference between chemical and organic evolution. Differentiate by giving three points.
67. There are a number of ways by which the genes enter a population. Explain briefly the three ways.

- 68.** Why can the wings of a bird and the wings of a bat not be considered analogous? (Imp.)
- 69.** How did the Mendelian 'factors' acquire a change in the terminology? Who changed it?
- 70.** What is palaeontology? What is its importance? (Imp.)
- 71.** The genotype of green stemmed tomato plants is denoted as GG and that of purple stemmed tomato plants is denoted as gg. When these two are crossed with each other: (a) What colour of stem would you expect in the F1 progeny?  
(b) Give the percentage of purple stemmed plants if F1 plants are self pollinated.  
(c) In what ratio would you find the genotypes GG and gg in the progeny?  
Draw flow chart in support of your answer.
- 72.** How has the method of artificial selection by humans helped in the evolution of different vegetables? Explain in brief giving an example.
- 73.** (a) Write two factors which could lead to the rise of a new species.  
(b) (i) What is the scientific term of the organs shown below? (ii) How do these organs provide evidence in support of evolution?
- 74.** (a) Name the type of sex chromosome present in human male and human female.  
(b) With the help of a flow chart determine genetically in human beings the sex of the offspring if a sperm carrying Xchromosome fertilizes the egg?
- 75.** In pea plant round seed is dominant over the wrinkled. If a cross is carried between these two plants, give answer to the following questions.  
(a) Mention the genes for the traits of parents.  
(b) State the trait of F1 hybrids.  
(c) Write the ratio of F2 progeny obtained from this cross. What is the name of the cross?  
[2011]
- 76.** Give appropriate terms for the following :  
(a) The trait which can express itself in next generation.  
(b) The trait an organism have due to inheritance.  
(c) Origin of a new species from pre-existing one.
- 77.** If a pure tall pea plant is crossed with a pure dwarf plant, then in the first generation only tall plants appear.  
(a) What happens to the traits of the dwarf plant?  
(b) In the second generation, the dwarf trait reappears. Why?
- 78.** How was it established that genes are located on the chromosomes?
- 79.** Clarify the terms 'haploid' and 'diploid'. What is the relation between the two terms?
- 80.** Explain the law of segregation by taking an example.

- 81.** If a trait A exists in 10% of a population of an asexually reproducing species and a trait B exists in 60% of the same species, which trait is likely to have arisen earlier?
- 82.** How does creation of variations in a species promote survival?
- 83.** 'Variations that confer an advantage to an individual organism only will survive in a population.' Justify.
- 84.** Suggest three similarities between Mendel's 'factors' and 'chromosomes'.
- 85.** Justify logically that many genes are present on one chromosome.
- .....

**ASSIGNMENT QUESTIONS SET – 2**  
**CHAPTER – 9**  
**HEREDITY AND EVOLUTION**

1. Exchange of genetic material takes place in
  - (a) vegetative reproduction
  - (b) asexual reproduction
  - (c) sexual reproduction
  - (d) budding
2. Two pink coloured flowers on crossing resulted in 1 red, 2 pink and 1 white flower progeny. The nature of the cross will be
  - (a) double fertilisation
  - (b) self pollination
  - (c) cross fertilisation
  - (d) no fertilisation
3. A cross between a tall plant (TT) and short pea plant (tt) resulted in progeny that were all tall plants because
  - (a) tallness is the dominant trait
  - (b) shortness is the dominant trait
  - (c) tallness is the recessive trait
  - (d) height of pea plant is not governed by gene 'T' or 't'
4. Which of the following statement is incorrect?
  - (a) For every hormone there is a gene.
  - (b) For every protein there is a gene.
  - (c) For production of every enzyme there is a gene.
  - (d) For every molecule of fat there is a gene
5. If a round, green seeded pea plant (RR yy) is crossed with wrinkled, yellow seeded pea plant, (rr YY) the seeds produced in F1 generation are
  - (a) round and yellow
  - (b) round and green
  - (c) wrinkled and green
  - (d) wrinkled and yellow
6. In human males all the chromosomes are paired perfectly except one. This/these unpaired chromosome is/are
  - (i) large chromosome
  - (ii) small chromosome



- (iii) Y-chromosome
  - (iv) X-chromosome
  - (a) (i) and (ii) (b) (iii) only
  - (c) (iii) and (iv) (d) (ii) and (iv)
- 7.** The maleness of a child is determined by
- (a) the X chromosome in the zygote
  - (b) the Y chromosome in zygote
  - (c) the cytoplasm of germ cell which determines the sex
  - (d) sex is determined by chance
- 8.** A zygote which has an X-chromosome inherited from the father will develop into a
- (a) boy
  - (b) girl
  - (c) X- chromosome does not determine the sex of a child
  - (d) either boy or girl
- 9.** Select the incorrect statement
- (a) Frequency of certain genes in a population change over several generations resulting in evolution
  - (b) Reduction in weight of the organism due to starvation is genetically controlled
  - (c) Low weight parents can have heavy weight progeny
  - (d) Traits which are not inherited over generations do not cause evolution
- 10.** New species may be formed if
- (i) DNA undergoes significant changes in germ cells
  - (ii) chromosome number changes in the gamete
  - (iii) there is no change in the genetic material
  - (iv) mating does not take place
- (a) (i) and (ii) (b) (i) and (iii)
  - (c) (ii), (iii) and (iv) (d) (i), (ii) and (iii)
- 11.** Two pea plants one with round green seeds (RRyy) and another with wrinkled yellow (rrYY) seeds produce F1 progeny that have round, yellow (RrYy) seeds. When F1 plants are selfed, the F2 progeny will have new combination of characters. Choose the new combination from the following
- (i) Round, yellow
  - (ii) Round, green
  - (iii) Wrinkled, yellow
  - (iv) Wrinkled, green

- (a) (i) and (ii) (b) (i) and (iv)  
(c) (ii) and (iii) (d) (i) and (iii)
- 12.** A basket of vegetables contains carrot, potato, radish and tomato. Which of them represent the correct homologous structures?
- (a) Carrot and potato  
(b) Carrot and tomato  
(c) Radish and carrot  
(d) Radish and potato
- 13.** Select the correct statement
- (a) Tendril of a pea plant and phylloclade of *Opuntia* are homologous  
(b) Tendril of a pea plant and phylloclade of *Opuntia* are analogous  
(c) Wings of birds and limbs of lizards are analogous  
(d) Wings of birds and wings of bat are homologous
- 14.** If the fossil of an organism is found in the deeper layers of earth, then we can predict that
- (a) the extinction of organism has occurred recently  
(b) the extinction of organism has occurred thousands of years ago  
(c) the fossil position in the layers of earth is not related to its time of extinction  
(d) time of extinction cannot be determined
- 15.** Which of the following statements is not true with respect to variation?
- (a) All variations in a species have equal chance of survival  
(b) Change in genetic composition results in variation  
(c) Selection of variants by environmental factors forms the basis of evolutionary processes.  
(d) Variation is minimum in asexual reproduction
- 16.** A trait in an organism is influenced by
- (a) paternal DNA only  
(b) maternal DNA only  
(c) both maternal and paternal DNA  
(d) neither by paternal nor by maternal DNA
- 17.** Select the group which shares maximum number of common characters
- (a) two individuals of a species  
(b) two species of a genus  
(c) two genera of a family  
(d) two genera of two families
- 18.** According to the evolutionary theory, formation of a new species is generally due to

- (a) sudden creation by nature
  - (b) accumulation of variations over several generations
  - (c) clones formed during asexual reproduction
  - (d) movement of individuals from one habitat to another
- 19.** From the list given below, select the character which can be acquired but not inherited
- (a) colour of eye
  - (b) colour of skin
  - (c) size of body
  - (d) nature of hair
- 20.** The two versions of a trait (character) which are brought in by the male and female gametes are situated on
- (a) copies of the same chromosome
  - (b) two different chromosomes
  - (c) sex chromosomes
  - (d) any chromosome
- 21.** Select the statements that describe characteristics of genes
- (i) genes are specific sequence of bases in a DNA molecule
  - (ii) a gene does not code for proteins
  - (iii) in individuals of a given species, a specific gene is located on a particular chromosome
  - (iv) each chromosome has only one gene
- (a) (i) and (ii) (b) (i) and (iii)
  - (c) (i) and (iv) (d) (ii) and (iv)
- 22.** In peas, a pure tall plant (TT) is crossed with a short plant (tt). The ratio of pure tall plants to short plants in F<sub>2</sub> is
- (a) 1 : 3
  - (b) 3 : 1
  - (c) 1 : 1
  - (d) 2 : 1
- 23.** The number of pair (s) of sex chromosomes in the zygote of humans is
- (a) one
  - (b) two
  - (c) three
  - (d) four
- 24.** The theory of evolution of species by natural selection was given by
- (a) Mendel (b) Darwin

(c) Morgan (d) Lamarck

25. Some dinosaurs had feathers although they could not fly but birds have feathers that help them to fly. In the context of evolution this means that
- (a) reptiles have evolved from birds
  - (b) there is no evolutionary connection between reptiles and birds
  - (c) feathers are homologous structures in both the organisms
  - (d) birds have evolved from reptiles
26. State one advantage of variation of a species. [2009]
27. What is the effect of DNA copying which is not perfectly accurate on the reproduction process? [2008]
28. What decides that humans give rise to humans? (Imp.)
29. What are hereditary characteristics?
30. Are the variations created by sexual reproduction heritable or non-heritable? (Imp.)
31. What are the components of a chromosome? (Imp.)
32. What is a retrovirus?
33. What is a sex chromosome?
34. How many chromosomes are there in a human ovum?
35. Who coined the term 'factor'? (Imp.)
36. Give the monohybrid ratio.
37. Write the dihybrid ratio.
38. Define the term 'speciation'.
39. What is a factor?
40. Name the most accepted theory of evolution.
41. Define the term 'evolution'.
42. Whose theory influenced Darwin? What did Darwin fail to explain? (Imp.)
43. Define 'recessive characteristic'.
44. What is the basis of sex determination in most plants and animals? (Imp.)
45. What are fossils? What do they tell about the process of evolution? [2008]
46. What do you understand by the term heredity? [2008]
47. What constitutes the link between one generation and the next? [2008]
48. "The sex of the children is determined by the what they inherit from their father and not from the mother." Justify. [2008]
49. Explain the terms analogous and homologous organs with one example of each. [2008]

50. A man with blood group A marries a woman with blood group O and their daughter has blood group O. Is this information enough to tell you which of the traits ‘blood group A or O’ is dominant? Why? [2008]
51. Define variation in relation to a species. Why is variation beneficial to the species? [2008]
52. Describe briefly four ways in which individuals with a particular trait may increase in a population. [2008]
53. What are acquired characteristics? (Imp.)
54. What is variation?
55. Why is variation less common in asexually reproducing organisms?
56. Clarify the term heredity and variation. (Imp.)
57. Define variation in relation to a species. Why is variation beneficial to the species? (Imp.)
58. What are autosomes?
59. What is the reason that a male is called 'heterogametic'? (Imp.)
60. What was the basic study material of Mendel? How did he bring in the term 'factor'?
61. Why are the traits acquired during lifetime of an individual not inherited? [2009]
62. How is the sex of a newborn determined in humans?
63. Do genetic combination of mothers play a significant role in determining the sex of a new born?
64. Mention three important features of fossils which help in the study of evolution.
65. Why do all the gametes formed in human females have an X chromosome?
66. In human beings, the statistical probability of getting either a male or female child is 50 : 50. Give a suitable explanation.
67. A very small population of a species faces a greater threat of extinction than a larger population. Provide a suitable genetic explanation.
68. What are homologous structures? Give an example. Is it necessary that homologous structures always have a common ancestor?
69. Does the occurrence of diversity of animals on earth suggest their diverse ancestry also? Discuss this point in the light of evolution.
70. Give the pair of contrasting traits of the following characters in pea plant and mention which is dominant and recessive (i) yellow seed (ii) round seed
71. Why did Mendel choose pea plant for his experiments?
72. A woman has only daughters. Analyse the situation genetically and provide a suitable explanation.
73. Does geographical isolation of individuals of a species lead to formation of a new species? Provide a suitable explanation.

- 74.** Bacteria have a simpler body plan when compared with human beings. Does it mean that human beings are more evolved than bacteria? Provide a suitable explanation.
- 75.** All the human races like Africans, Asians, Europeans, Americans and others might have evolved from a common ancestor. Provide a few evidences in support of this view.
- 76.** Differentiate between inherited and acquired characters. Give one example for each type.
- 77.** Give reasons why acquired characters are not inherited.
- 78.** Evolution has exhibited a greater stability of molecular structure when compared with morphological structures. Comment on the statement and justify your opinion.
- 79.** Give the basic features of the mechanism of inheritance.
- 80.** Give reasons for the appearance of new combinations of characters in the F<sub>2</sub> progeny.
- .....

## CHAPTER - 12

### ELECTRICITY

Electricity is a general term that encompasses a variety of phenomena resulting from the presence and flow of electric charge. These include many easily recognizable phenomena such as lightning and static electricity, but in addition, less familiar concepts such as the electromagnetic field and electromagnetic induction.

#### **Electric charge**

Electric charge is a fundamental conserved property of some subatomic particles, which determines their electromagnetic interaction. Electrically charged matter is influenced by, and produces, electromagnetic fields. The interaction between a moving charge and an electromagnetic field is the source of the electromagnetic force, which is one of the four fundamental forces. Electric charge is conserved, additive and quantised. The S.I. unit of electric charge is 'C' coulomb.

Any other charged body will have a charge Q

$$Q = ne$$

where n is the number of electrons and e is the charge on electron =  $1.6 \times 10^{-19}$  coulombs.

#### **Electric current**

Electric current is a flow of electrons in a conductor such as a metal wire. Electric current is expressed by the amount of charge flowing through a particular area in unit time. In other words, it is the rate of flow of electric charges. In circuits using metallic wires, electrons constitute the flow of charges. However, electrons were not known at the time when the phenomenon of electricity was first observed. So, electric current was considered to be the flow of positive charges and the direction of flow of positive charges was taken to be the direction of electric current. Conventionally, in an electric circuit the direction of electric current is taken as opposite to the direction of the flow of electrons, which are negative charges.

The magnitude of electric current in a conductor is the amount of electric charge passing through a given point of conductor in 1 second.

$$I = \frac{Q}{t}$$

S.I. unit of electric current is 'A' (Ampere).

The electric current is expressed by a unit called ampere (A), named after the French scientist, Andre-Marie Ampere (1775–1836).

#### **One Ampere**

When 1 coulomb of charge flows through any cross-section of a conductor in 1 second, the electric charge flowing through it is said to be 1 ampere.

Smaller unit current is milliampere(mA) and microampere( $\mu$  A)

$$1 \text{ mA} = 10^{-3} \text{ A}$$

$$1 \mu \text{ A} = 10^{-6} \text{ A}$$

An instrument called ammeter measures electric current in a circuit. It is always connected in series in a circuit through which the current is to be measured.

The direction of electric current is from positive terminal to negative terminal through the electric circuit.

## **INTEXT QUESTIONS PAGE NO. 200**

### **1. What does an electric circuit mean?**

**Ans.** An electric circuit consists of electric devices, switching devices, source of electricity, etc. that are connected by conducting wires.

### **2. Define the unit of current.**

**Ans.** The unit of electric current is ampere (A). 1 A is defined as the flow of 1 C of charge through a wire in 1 s.

### **3. Calculate the number of electrons constituting one coulomb of charge.**

**Ans.** One electron possesses a charge of  $1.6 \times 10^{-19}$  C, i.e.,  $1.6 \times 10^{-19}$  C of charge is contained in 1 electron.

$$\therefore 1 \text{ C of charge is contained in } \frac{1}{1.6 \times 10^{-19}} = 6.25 \times 10^{18} \text{ electrons}$$

Therefore,  $6.25 \times 10^{18}$  electrons constitute one coulomb of charge.

### **Potential difference**

Potential difference,  $V_A - V_B$  between two points A and B is the work done per unit charge in taking a charge from B to A.

Potential difference,  $V_A - V_B = \frac{\text{work done}}{\text{charge}}$ , where  $V_A$  is potential at point A,  $V_B$  is

potential at point B and S.I. unit of potential is volts (V), named after Alessandro Volta (1745–1827), an Italian physicist.

### **Electric Potential**

Electric Potential at a point is defined as the work done per unit charge in bringing a charge from infinity to that point.

$$V = \frac{\text{work done}}{\text{charge}} = \frac{W}{Q}$$

The potential difference is measured by means of an instrument called the voltmeter. The voltmeter is always connected in parallel across the points between which the potential difference is to be measured.

**One volt:** The potential difference between two points is said to be 1 volt if 1 joule of work is done in moving 1 coulomb of electric charge from one point to the other. Electrons always flow from lower potential to higher potential.

## **INTEXT QUESTIONS PAGE NO. 202**

### **1. Name a device that helps to maintain a potential difference across a conductor.**

**Ans.** A source of electricity such as cell, battery, power supply, etc. helps to maintain a potential difference across a conductor.

### **2. What is meant by saying that the potential difference between two points is 1 V?**

**Ans.** If 1 J of work is required to move a charge of amount 1 C from one point to another, then it is said that the potential difference between the two points is 1 V.



**3. How much energy is given to each coulomb of charge passing through a 6 V battery?**

**Ans.** The energy given to each coulomb of charge is equal to the amount of work required to move it. The amount of work is given by the expression,

$$\text{Potential difference} = \frac{\text{Work done}}{\text{Charge}}$$

$$\text{Work done} = \text{Potential difference} \times \text{Charge}$$

Where, Charge = 1 C and Potential difference = 6 V

$$\text{Work done} = 6 \times 1 = 6 \text{ J}$$

Therefore, 6 J of energy is given to each coulomb of charge passing through a battery of 6 V.

### **NUMERICAL PROBLEMS**

1. Find the charge if the number of electrons is  $4 \times 10^{-18}$ .
2. Find the number of electrons constituting one coulomb of charge.
3. How much work done in moving a charge of 3 coulombs from a point at 118 V to a point at 128 volt?
4. How much work done in moving a charge of 2C across two points having a potential difference of 12V?
5. Calculate the amount of work done to carry 4C from a point at 100 V to a point at 120 volt?
6. How much work will be done in bringing a charge of  $2 \times 10^{-3}$  coulombs from infinity to a point P at which the potential is 5 V?
7. How much work will be done in bringing a charge of  $3 \times 10^{-2}$  coulombs from infinity to a point P at which the potential is 20 V?
8. How much energy is given to each coulomb of charge passing through a 6V battery?
9. How much energy is transferred by a 12 V power supply to each coulomb of charge which it moves around a circuit?
10. What is the potential difference between the terminals of a battery if 250 joules of work is required to transfer 20 coulombs of charge from one terminal of battery to the other?
11. What is the potential difference between the conductors A and B shown in below figure? If the conductors are connected by a length of wire, which way will electrons flow? When will this flow of electrons stop?

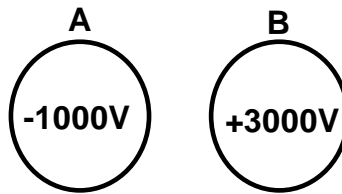

12. A particle of charge  $2C$  is taken from a point at a potential of  $100V$  to another point at a potential of  $150V$ . Calculate the work done.
13. What is the potential difference between the conductors A and B shown in below figure? If the conductors are connected by a length of wire, which way will electrons flow? When will this flow of electrons stop?

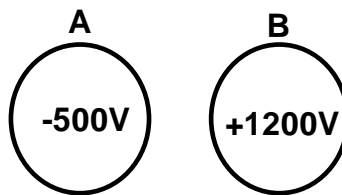

14. A particle of charge  $5 \times 10^{-2} C$  is taken from a point at a potential of  $50V$  to another point at a potential of  $250V$ . Calculate the work done.
15. Three  $2V$  cells are connected in series and used as a battery in a circuit.
- (a) What is the potential difference at the terminals of the battery?
- (b) How many joules of electrical energy does  $1 C$  gain on passing through (i) one cell (ii) all three cells.

### CIRCUIT DIAGRAM

The Schematic diagram, in which different components of the circuit are represented by the symbols conveniently used, is called a circuit diagram. Conventional symbols used to represent some of the most commonly used electrical components are given below:

1. An electric cell

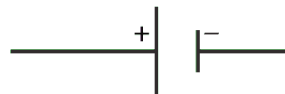

2. A battery or a combination of cells



3. Plug key or switch (open)



4. Plug key or switch (closed)



5. A wire joint



6. Wires crossing without joining

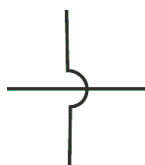

7. Electric bulb

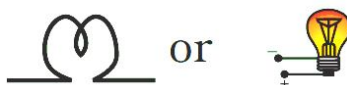

8. A resistor of resistance  $R$



9. Variable resistance or rheostat

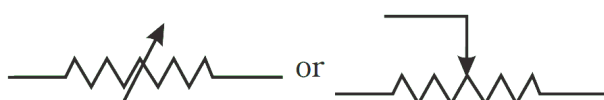

10. Ammeter



11. Voltmeter



### Ohm's law

According to Ohm's law, "At constant temperature, the current flowing through a conductor is directly proportional to the potential difference across its ends."

$$I \propto V \text{ or } V \propto I \text{ at constant temperature}$$

$V = IR$  where  $R$  is constant of proportionality which is known as resistance.

### Resistance

It is the ratio of potential difference applied between the ends of a conductor and the current flowing through it. The unit of resistance is ohm ( $\Omega$ ).

$$R = \frac{V}{I} \Rightarrow I = \frac{V}{R}$$

$$1 \text{ ohm} = \frac{1 \text{ volt}}{1 \text{ ampere}}$$

### One Ohm

One Ohm is the resistance of a conductor such that when a potential difference of 1 volt is applied to its ends, a current of 1 ampere flows through it.

If the resistance is doubled the current gets halved. In many practical cases it is necessary to increase or decrease the current in an electric circuit. A component used to regulate current without changing the voltage source is called variable resistance. In an electric circuit, a device called rheostat is often used to change the resistance in the circuit.

### Factors on which the Resistance of a conductor depends

The resistance of the conductor depends (i) on its length, (ii) on its area of cross-section, and (iii) on the nature of its material.

**Resistance depends on area of cross section:** It is inversely proportional to the area of cross section (A)

$$R \propto \frac{1}{A}$$

**Resistance depends on length of wire:** It is directly proportional to the length of the wire (l)

$$R \propto l$$

Combining the above we get  $R \propto \frac{l}{A}$

$$\Rightarrow R = \rho \frac{l}{A}$$

where  $\rho$  (rho) is a constant of proportionality which is called the resistivity or specific resistance of the material.

$$\text{If } l = 1\text{m, } A = 1\text{m}^2 \text{ then } R = \rho$$

Resistivity of a material is the resistance of a unit length of the material having unit area of cross section.

### **INTEXT QUESTIONS PAGE NO. 209**

**1. On what factors does the resistance of a conductor depend?**

**Ans.** The resistance of a conductor depends upon the following factors:

- (a) Length of the conductor
- (b) Cross-sectional area of the conductor
- (c) Material of the conductor
- (d) Temperature of the conductor

**2. Will current flow more easily through a thick wire or a thin wire of the same material, when connected to the same source? Why?**

**Ans.** Resistance of a wire,

$$\text{Where, } R = \rho \frac{l}{A}$$

$\rho$  = Resistivity of the material of the wire

$l$  = Length of the wire

$A$  = Area of cross-section of the wire

Resistance is inversely proportional to the area of cross-section of the wire.

Thicker the wire, lower is the resistance of the wire and vice-versa. Therefore, current can flow more easily through a thick wire than a thin wire.

**3. Let the resistance of an electrical component remains constant while the potential difference across the two ends of the component decreases to half of its former value. What change will occur in the current through it?**

**Ans.** The change in the current flowing through the component is given by Ohm's law as,

$$V = IR$$

$$I = \frac{V}{R}$$

Where,

Resistance of the electrical component =  $R$

Potential difference =  $V$

Current =  $I$

The potential difference is reduced to half, keeping resistance constant.

Let the new resistance be  $R'$  and the new amount of current be  $I'$ .  
Therefore, from Ohm's law, we obtain the amount of new current.

$$I' = \frac{V'}{R'} = \frac{V/2}{R} = \frac{1}{2} \left( \frac{V}{R} \right) = \frac{1}{2} I$$

Therefore, the amount of current flowing through the electrical component is reduced by half.

**4. Why are coils of electric toasters and electric irons made of an alloy rather than a pure metal?**

**Ans.** The resistivity of an alloy is higher than the pure metal. Moreover, at high temperatures, the alloys do not melt readily. Hence, the coils of heating appliances such as electric toasters and electric irons are made of an alloy rather than a pure metal.

**5. (a) Which among iron and mercury is a better conductor?**

**(b) Which material is the best conductor?**

**Ans.** (a) Resistivity of iron =  $10.0 \times 10^{-8} \Omega m$

Resistivity of mercury =  $94.0 \times 10^{-8} \Omega m$

Resistivity of mercury is more than that of iron. This implies that iron is a better conductor than mercury.

(b) It can be observed from Table 12.2 that the resistivity of silver is the lowest among the listed materials. Hence, it is the best conductor.

**NUMERICAL PROBLEMS**

1. What current must flow if 0.24 coulombs is to be transferred in 15 ms?
2. If a current of 10 A flows for four minutes, find the quantity of electricity transferred.
3. An electric bulb draws a current of 0.25A for 20 minutes. Calculate the electric charge that flows through the circuit.
4. If the amount of electric charge passing through a conductor in 10min is 300C, find the current.
5. How many electrons are flowing per second past a point in a circuit in which there is a current of 4A?
6. A lamp of resistance  $80\Omega$  draw a current of 0.75A. Find the line voltage.
7. A electric heater draw a current of 5A when connected to 220V mains. Calculate the resistance of its filament.
8. How much current will an electric bulb draw from a 200V source, if the resistance of the filament is  $1200\Omega$ ?
9. How much current will an electric heater draw from a 200V source, if the resistance of the filament is  $100\Omega$ ?

10. How much current does an electric heater draw from a 220V line, if the resistance of the heater (when hot) is  $50\Omega$ ?
11. A bulb when cold has  $1\Omega$  resistance. It draws a current of 0.3A when glowing from a source of 3V. Calculate the resistance of the bulb when glowing and explain the reason for the difference in resistance.
12. Calculate the potential difference required across a conductor of resistance  $5\Omega$  to make a current of 1.5A flow through it.
13. What is the resistance of an electric lamp when hot, if the lamp uses 20A when connected to a 220V line?
14. Calculate the amount of work done to draw a current of 8A from a point at 100V to a point at 120V in 2 seconds.
15. If 200C of charge pass a point in a circuit in 4 sec, what current is flowing?
16. A current of 4A flows around a circuit in 10 seconds. How much charge flows past a point in the circuit in this time? Also find the number of electrons that pass in the circuit.
17. The current flowing through a resistor is 0.8 A when a p.d. of 20 V is applied. Determine the value of the resistance.
18. Determine the p.d. which must be applied to a  $2\text{ k}\Omega$  resistor in order that a current of 10 mA may flow.
19. A coil has a current of 50 mA flowing through it when the applied voltage is 12 V. What is the resistance of the coil?
20. A 100 V battery is connected across a resistor and causes a current of 5 mA to flow. Determine the resistance of the resistor. If the voltage is now reduced to 25 V, what will be the new value of the current flowing?
21. What is the resistance of a coil which draws a current of (a) 50 mA and (b) 200  $\mu\text{A}$  from a 120 V supply?
22. If a current of 5 A flows for 2 minutes, find the quantity of electricity transferred.
23. A current of 0.5 A is drawn by a filament of an electric bulb for 10 minutes. Find the amount of electric charge that flows through the circuit.
24. How much current will an electric bulb draw from a 220 V source, if the resistance of the bulb filament is  $1200\Omega$ ?
25. How much current will an electric heater coil draw from a 220 V source, if the resistance of the heater coil is  $100\Omega$ ?

26. The potential difference between the terminals of an electric heater is 60 V when it draws a current of 4 A from the source. What current will the heater draw if the potential difference is increased to 120 V?
27. When a 12 V battery is connected across an unknown resistor, there is a current of 2.5 mA in the circuit. Find the value of the resistance of the resistor.
28. An electric heater is connected to the 230 V mains supply. A current of 8A flows through the heater (a) How much charge flows around the circuit each second. (b)How much energy is transferred to the heater each second?
29. How many electrons are flowing per second past a point in a circuit in which there is a current of 5A?
30. An electric iron draws a current of 3.4A from the 220V supply line. What current will this electric iron draw when connected to 110V supply line?
31. A simple electric circuit has a 24V battery and a resistor of  $60\Omega$ . What will be the current in the circuit?
32. When a  $4\Omega$  resistor is connected across the terminal of 12V battery, find the number of coulombs passing through the resistor per second.
33. An electric room heater draw a current of 2.4A from the 120V supply line. What current will this room heater draw when connected to 240V supply line?
34. A current of 200mA flows through a  $4k\Omega$  resistor. What is the p.d. across the resistor?
35. A p.d. of 10V is needed to make a current of 0.02 A flow through a wire. What p.d. is needed to make a current of 250mA flow through the same wire?
36. A TV draws a current of 5 A from the 240V supply line. What current will this TV draw when it is connected to 100V supply line.
37. The potential difference between the terminals of an electric heater is 60V when it draw a current of 4A from the source. What current will the heater draw if the potential difference is increased to 120V?
38. A bulb of resistance  $400\Omega$  is connected to 220V mains. Calculate the magnitude of current.
39. A battery of two cells is used to light a torch bulb of resistance  $5\Omega$ . The cells maintain a potential difference of 3V across the bulb. How much current will flow through the bulb?
40. A steady current of 5A flows through a circuit for 30minutes. How much charge has circulated through the circuit in this time?

## NUMERICAL PROBLEMS ON RESISTIVITY

1. Calculate the resistance of a copper wire of length 2m and area of cross section  $10^{-6}\text{m}^2$ . Resistivity of copper is  $1.7 \times 10^{-8} \Omega \text{ m}$
2. A copper wire of length 2m and area of cross section  $1.7 \times 10^{-6}\text{m}^2$  has a resistance of  $2 \times 10^{-2}$  ohms. Calculate the resistivity of copper.
3. The amount of charge passing through a cell in 12 seconds is 3C. What is the current supplied by the cell?
4. A 12 V battery of a car is connected across a  $4\Omega$  resistor. Calculate the current passing through the resistor.
5. Resistivity of a given copper wire of length 2m is  $1.7 \times 10^{-8} \Omega \text{ m}$ . The wire is stretched so that its length becomes 4m. Find new resistivity of the copper wire.
6. Resistance of a given wire of length ' $l$ ' is  $3\Omega$ . The wire is stretched uniformly such that its length becomes  $2l$ . Find the new resistance of the stretched wire.
7. Resistance of a given wire of length ' $l$ ' is  $4\Omega$ . The wire is stretched uniformly such that its length becomes  $3l$ . Find the new resistance of the stretched wire.
8. A copper wire has a diameter of 0.5 mm and resistivity of  $1.6 \times 10^{-8} \Omega \text{ m}$ . What will be the length of this wire to make its resistance  $10\Omega$ ? How much does the resistance change if the diameter is doubled?
9. A  $6\Omega$  resistance wire is doubled up by folding. Calculate the new resistance of the wire.
10. Calculate the resistance of an aluminium cable of length 10km and diameter 20mm if the resistivity of aluminum is  $2.7 \times 10^{-8} \Omega \text{ m}$ .
11. Calculate the area of cross section of a wire if its length is 1.0m, its resistance is  $23\Omega$  and the resistivity of the material of the wire is  $1.84 \times 10^{-6} \Omega \text{ m}$ .
12. A piece of wire of resistance  $20\Omega$  is drawn out so that its length is increased to twice its original length. Calculate the resistance of the wire in the new situation.
13. Two cylindrical wires of the same material have their lengths in the ratio of 4 : 9. What should be the ratio of their radii so that their resistances are in the ratio of 4 : 1?
14. Two wires of the same metal, have the same area of cross section but their lengths in the ratio of 3 : 1. What should be the ratio of current flowing through them respectively, when the same potential difference is applied across each of their length?
15. Two wires A and B of length 30m and 10m have radii 2cm and 1cm respectively. Compare the resistances of the two wires. Which will have less resistance?



16. Calculate the resistance of 1km long copper wire of radius 1mm. Resistivity of copper is  $1.7 \times 10^{-8} \Omega \text{ m}$
17. A  $4\Omega$  wire is doubled on it. Calculate the new resistance of the wire.
18. What should be the length of the nichrome wire of resistance  $4.5\Omega$ , if the length of a similar wire is 60cm and resistance  $2.5\Omega$ ?
19. A metal wire of resistivity  $64 \times 10^{-6} \Omega \text{ m}$  and length 198cm has a resistance of  $7\Omega$ . Calculate its radius.
20. Calculate the resistivity of the material of a wire 1.0m long, 0.4mm in diameter and having a resistance of  $2.0\Omega$ .

## RESISTANCE OF A SYSTEM OF RESISTORS

### RESISTORS IN SERIES

#### In a series circuit

- (a) the current  $I$  is the same in all parts of the circuit, and
- (b) the sum of the voltages  $V_1$ ,  $V_2$  and  $V_3$  is equal to the total applied voltage,  $V$ , i.e.

$$V = V_1 + V_2 + V_3$$

From Ohm's law:

$$V_1 = IR_1,$$

$$V_2 = IR_2,$$

$$V_3 = IR_3$$

and  $V = IR$

where  $R$  is the total circuit resistance.

$$\text{Since } V = V_1 + V_2 + V_3$$

$$\text{then } IR = IR_1 + IR_2 + IR_3$$

Dividing throughout by  $I$  gives

$$\mathbf{R = R_1 + R_2 + R_3}$$

Thus for a series circuit, the total resistance is obtained by adding together the values of the separate resistances.

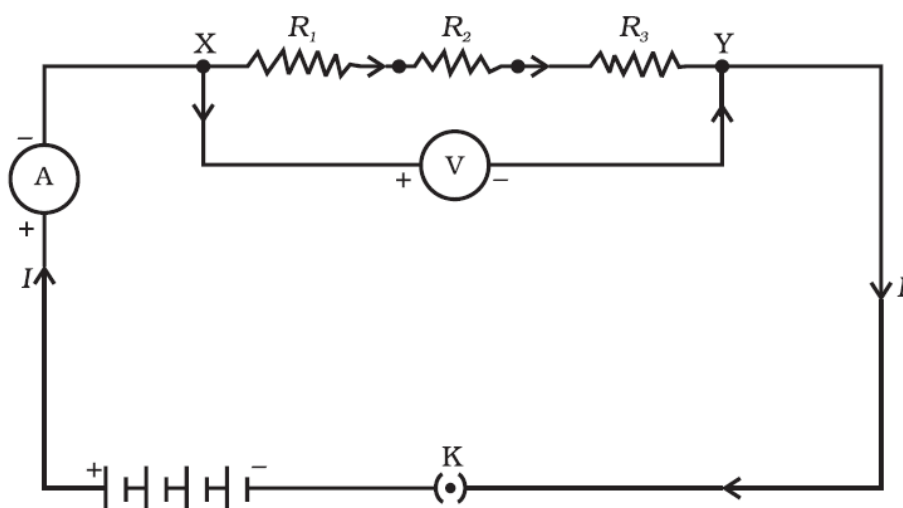

When several resistors are connected in series, the resistance of the combination  $R_s$  is equal to the sum of their individual resistances  $R_1$ ,  $R_2$ ,  $R_3$  and is thus greater than any individual resistance.

## RESISTORS IN PARALLEL

### **In a parallel circuit:**

(a) the sum of the currents  $I_1$ ,  $I_2$  and  $I_3$  is equal to the total circuit current,  $I$ , i.e.  $I = I_1 + I_2 + I_3$ , and

(b) the source p.d.,  $V$  volts, is the same across each of the resistors.

From Ohm's law:

$$I_1 = \frac{V}{R_1}, \quad I_2 = \frac{V}{R_2}, \quad I_3 = \frac{V}{R_3} \quad \text{and} \quad I = \frac{V}{R}$$

where  $R$  is the total resistance of the circuit.

Since  $I = I_1 + I_2 + I_3$

$$\text{then } \frac{V}{R} = \frac{V}{R_1} + \frac{V}{R_2} + \frac{V}{R_3}$$

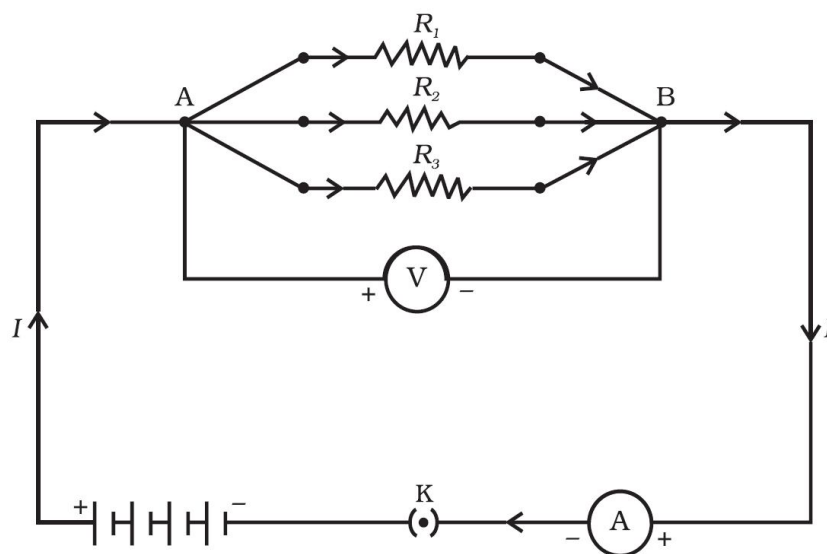

dividing throughout by  $V$ , we get

$$\frac{1}{R} = \frac{1}{R_1} + \frac{1}{R_2} + \frac{1}{R_3}$$

This equation must be used when finding the total resistance  $R$  of a parallel circuit.

Thus the reciprocal of the equivalent resistance of a group of resistance joined in parallel is equal to the sum of the reciprocals of the individual resistance.

For the special case of **two resistors in parallel**

$$\frac{1}{R} = \frac{1}{R_1} + \frac{1}{R_2} = \frac{R_1 + R_2}{R_1 R_2}$$

$$\text{Hence } R = \frac{R_1 R_2}{R_1 + R_2} \quad \text{i.e. } \left( \frac{\text{product}}{\text{sum}} \right)$$

## INTEXT QUESTIONS PAGE NO. 213

**1. Draw a schematic diagram of a circuit consisting of a battery of three cells of 2 V each, a 5  $\Omega$  resistor, an 8  $\Omega$  resistor, and a 12  $\Omega$  resistor, and a plug key, all connected in series.**

**Ans.** Three cells of potential 2 V, each connected in series, is equivalent to a battery of potential 2 V + 2 V + 2 V = 6V. The following circuit diagram shows

three resistors of resistances  $5\ \Omega$ ,  $8\ \Omega$  and  $12\ \Omega$  respectively connected in series and a battery of potential  $6\ \text{V}$ .

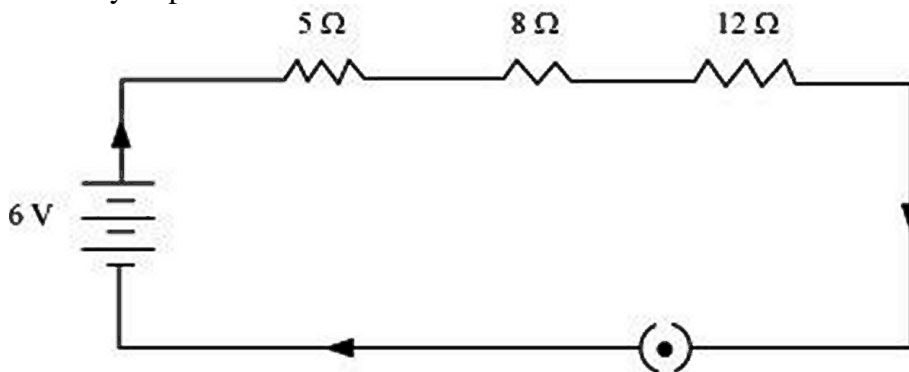

2. Redraw the circuit of question 1, putting in an ammeter to measure the current through the resistors and a voltmeter to measure potential difference across the  $12\ \Omega$  resistor. What would be the readings in the ammeter and the voltmeter?

**Ans.** To measure the current flowing through the resistors, an ammeter should be connected in the circuit in series with the resistors. To measure the potential difference across the  $12\ \Omega$  resistor, a voltmeter should be connected parallel to this resistor, as shown in the following figure.

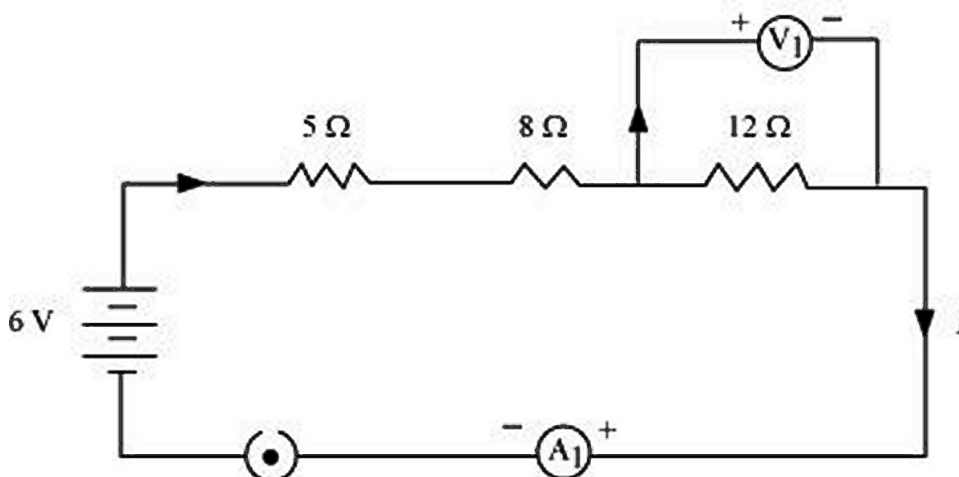

The resistances are connected in series.

Ohm's law can be used to obtain the readings of ammeter and voltmeter. According to Ohm's law,

$$V = IR,$$

where, Potential difference,  $V = 6\ \text{V}$

Current flowing through the circuit/resistors =  $I$

Resistance of the circuit,  $R = 5 + 8 + 12 = 25\ \Omega$

$$I = \frac{V}{R} = \frac{6}{25} = 0.24\ \text{A}$$

Potential difference across  $12\ \Omega$  resistor =  $V_1$

Current flowing through the  $12\ \Omega$  resistor,  $I = 0.24\ \text{A}$

Therefore, using Ohm's law, we obtain

$$V_1 = IR = 0.24 \times 12 = 2.88\ \text{V}$$

Therefore, the reading of the ammeter will be  $0.24\ \text{A}$ .

The reading of the voltmeter will be  $2.88\ \text{V}$ .

### INTEXT QUESTIONS PAGE NO. 216

1. Judge the equivalent resistance when the following are connected in parallel  
– (a)  $1\ \Omega$  and  $10^6\ \Omega$ , (b)  $1\ \Omega$  and  $10^3\ \Omega$  and  $10^6\ \Omega$ .

**Ans.** (a) When  $1 \Omega$  and  $10^6 \Omega$  are connected in parallel:

Let  $R$  be the equivalent resistance.

$$\therefore \frac{1}{R} = \frac{1}{1} + \frac{1}{10^6}$$

$$R = \frac{10^6}{10^6 + 1} \approx \frac{10^6}{10^6} = 1\Omega$$

Therefore, equivalent resistance =  $1 \Omega$

(b) When  $1 \Omega$ ,  $10^3 \Omega$  and  $10^6 \Omega$  are connected in parallel:

Let  $R$  be the equivalent resistance.

$$\frac{1}{R} = \frac{1}{1} + \frac{1}{10^3} + \frac{1}{10^6} = \frac{10^6 + 10^3 + 1}{10^6}$$

$$R = \frac{1000000}{1001001} = 0.999\Omega$$

Therefore, equivalent resistance =  $0.999 \Omega$

2. **An electric lamp of  $100 \Omega$ , a toaster of resistance  $50 \Omega$ , and a water filter of resistance  $500 \Omega$  are connected in parallel to a  $220 \text{ V}$  source. What is the resistance of an electric iron connected to the same source that takes as much current as all three appliances, and what is the current through it?**

**Ans.** Resistance of electric lamp,  $R_1 = 100 \Omega$

Resistance of toaster,  $R_2 = 50 \Omega$

Resistance of water filter,  $R_3 = 500 \Omega$

Voltage of the source,  $V = 220 \text{ V}$

These are connected in parallel, as shown in the following figure.

Let  $R$  be the equivalent resistance of the circuit.

$$\frac{1}{R} = \frac{1}{R_1} + \frac{1}{R_2} + \frac{1}{R_3} = \frac{1}{100} + \frac{1}{50} + \frac{1}{500}$$

$$\Rightarrow \frac{1}{R} = \frac{5+10+1}{500} = \frac{16}{500}$$

$$\Rightarrow R = \frac{500}{16} \Omega$$

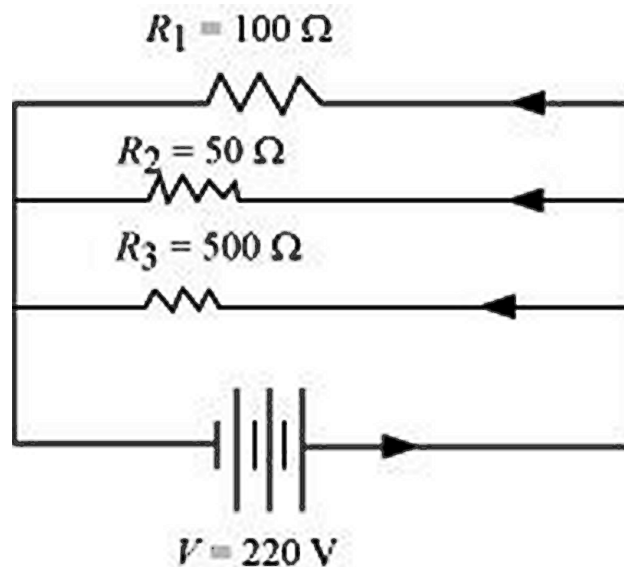

According to Ohm's law,  $V = IR$

$$I = \frac{V}{R} \text{ Where, Current flowing through the circuit} = I$$

$$I = \frac{V}{R} = \frac{220}{500/16} = \frac{220 \times 16}{500} = 7.04 A$$

7.04 A of current is drawn by all the three given appliances.

Therefore, current drawn by an electric iron connected to the same source of potential 220 V = 7.04 A

Let  $R'$  be the resistance of the electric iron. According to Ohm's law,

$$V = IR' \Rightarrow R' = \frac{V}{I} = \frac{220}{7.04} = 31.25 \Omega$$

Therefore, the resistance of the electric iron is 31.25  $\Omega$  and the current flowing through it is 7.04 A.

**3. What are the advantages of connecting electrical devices in parallel with the battery instead of connecting them in series?**

**Ans.** There is no division of voltage among the appliances when connected in parallel. The potential difference across each appliance is equal to the supplied voltage. The total effective resistance of the circuit can be reduced by connecting electrical appliances in parallel.

**4. How can three resistors of resistances 2  $\Omega$ , 3  $\Omega$  and 6  $\Omega$  be connected to give a total resistance of (a) 4  $\Omega$ , (b) 1  $\Omega$ ?**

**Ans.** There are three resistors of resistances 2  $\Omega$ , 3  $\Omega$ , and 6  $\Omega$  respectively.

(a) The following circuit diagram shows the connection of the three resistors.

Here, 6  $\Omega$  and 3  $\Omega$  resistors are connected in parallel.

Therefore, their equivalent resistance will be given by

$$R = \frac{1}{\frac{1}{R_1} + \frac{1}{R_2}} = \frac{1}{\frac{1}{6} + \frac{1}{3}} = \frac{6 \times 3}{6 + 3} = 2 \Omega$$

This equivalent resistor of resistance 2  $\Omega$  is connected to a 2  $\Omega$  resistor in series.

Therefore, equivalent resistance of the circuit = 2  $\Omega$  + 2  $\Omega$  = 4  $\Omega$

Hence, the total resistance of the circuit is 4  $\Omega$

The following circuit diagram shows the connection of the three resistors.

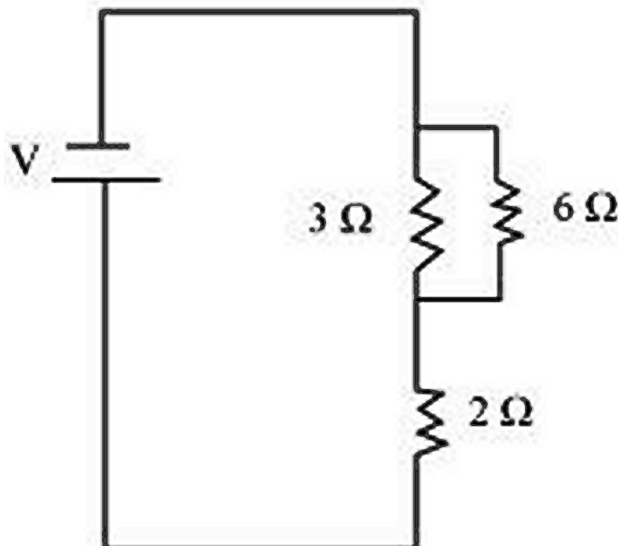

All the resistors are connected in series. Therefore, their equivalent resistance will be given as

$$R = \frac{1}{\frac{1}{R_1} + \frac{1}{R_2} + \frac{1}{R_3}} = \frac{1}{\frac{1}{2} + \frac{1}{3} + \frac{1}{6}} = \frac{1}{\frac{3+2+1}{6}} = \frac{6}{6} = 1\Omega$$

Therefore, the total resistance of the circuit is  $1\Omega$

5. What is (a) the highest, (b) the lowest total resistance that can be secured by combinations of four coils of resistance  $4\Omega$ ,  $8\Omega$ ,  $12\Omega$ ,  $24\Omega$ ?

**Ans.** There are four coils of resistances  $4\Omega$ ,  $8\Omega$ ,  $12\Omega$  and  $24\Omega$  respectively

(a) If these coils are connected in series, then the equivalent resistance will be the highest, given by the sum  $4 + 8 + 12 + 24 = 48\Omega$

(b) If these coils are connected in parallel, then the equivalent resistance will be the lowest, given by

$$R = \frac{1}{\frac{1}{R_1} + \frac{1}{R_2} + \frac{1}{R_3} + \frac{1}{R_4}} = \frac{1}{\frac{1}{4} + \frac{1}{8} + \frac{1}{12} + \frac{1}{24}} = \frac{1}{\frac{6+3+2+1}{24}} = \frac{24}{12} = 2\Omega$$

Therefore,  $2\Omega$  is the lowest total resistance.

### NUMERICAL PROBLEMS

1. For the circuit shown in below Figure, determine (a) the battery voltage  $V$ , (b) the total resistance of the circuit, and (c) the values of resistance of resistors  $R_1$ ,  $R_2$  and  $R_3$ , given that the p.d.'s across  $R_1$ ,  $R_2$  and  $R_3$  are  $5\text{ V}$ ,  $2\text{ V}$  and  $6\text{ V}$  respectively.

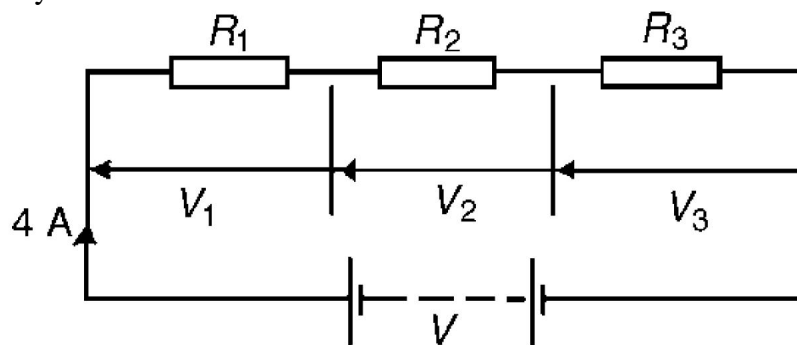

2. For the circuit shown in below Figure, determine the p.d. across resistor  $R_3$ . If the total resistance of the circuit is  $100\Omega$ , determine the current flowing through resistor  $R_1$ . Find also the value of resistor  $R_2$

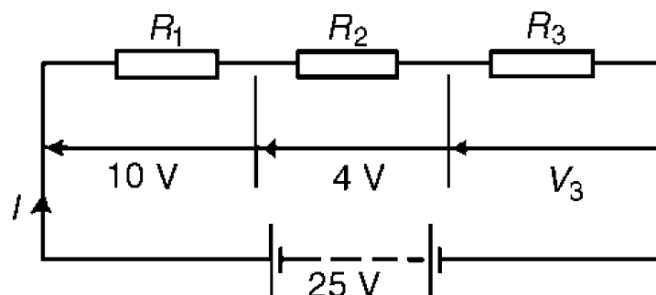

3. A  $12\text{ V}$  battery is connected in a circuit having three series-connected resistors having resistances of  $4\Omega$ ,  $9\Omega$  and  $11\Omega$ . Determine the current flowing through, and the p.d. across the  $9\Omega$  resistor.

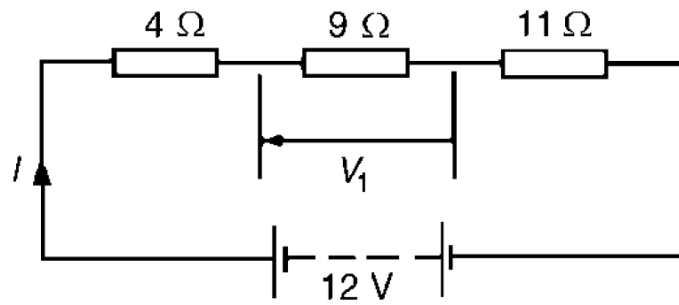

4. Find the voltage  $V$  in the given figure.

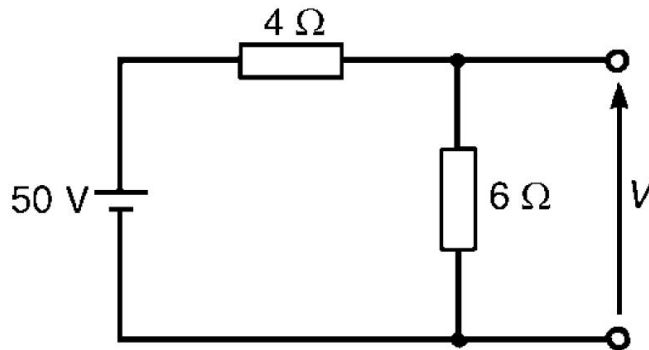

5. For the circuit shown in given Figure, determine (a) the reading on the ammeter, and (b) the value of resistor  $R_2$

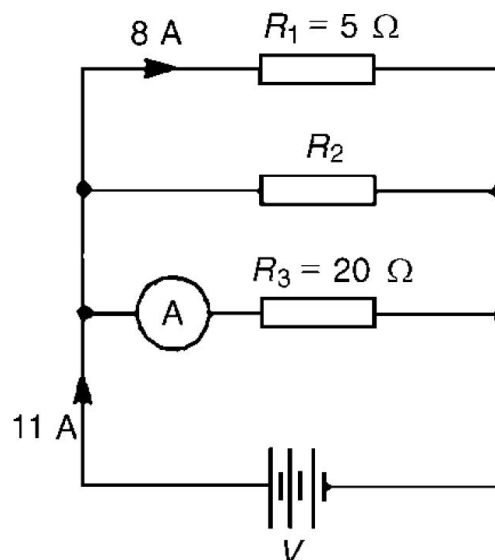

6. Two resistors are connected in series across a 24 V supply and a current of 3 A flows in the circuit. If one of the resistors has a resistance of  $2\Omega$  determine (a) the value of the other resistor, and (b) the p.d. across the  $2\Omega$  resistor. If the circuit is connected for 50 hours, how much energy is used?
7. Two resistors, of resistance  $3\Omega$  and  $6\Omega$ , are connected in parallel across a battery having a voltage of 12 V. Determine (a) the total circuit resistance and (b) the current flowing in the  $3\Omega$  resistor.

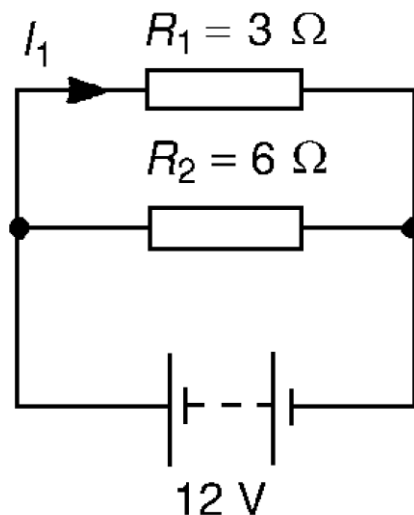

8. Given four  $1\ \Omega$  resistors, state how they must be connected to give an overall resistance of (a)  $\frac{1}{4}\ \Omega$  (b)  $1\ \Omega$  (c)  $1\frac{1}{3}\ \Omega$  (d)  $2\frac{1}{2}\ \Omega$ , all four resistors being connected in each case.
9. For the circuit shown in below Figure, find (a) the value of the supply voltage  $V$  and (b) the value of current  $I$ .

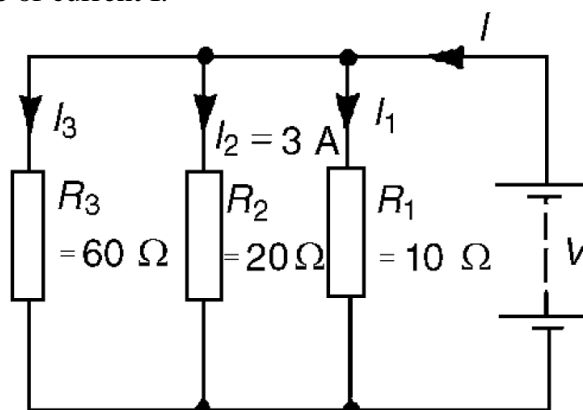

10. For the series-parallel arrangement shown in below Figure, find (a) the supply current, (b) the current flowing through each resistor and (c) the p.d. across each resistor.

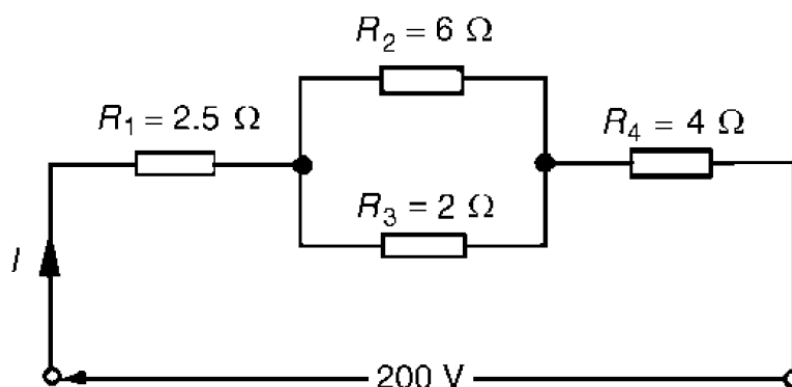

11. For the arrangement shown in below Figure, find the current  $I_x$ .



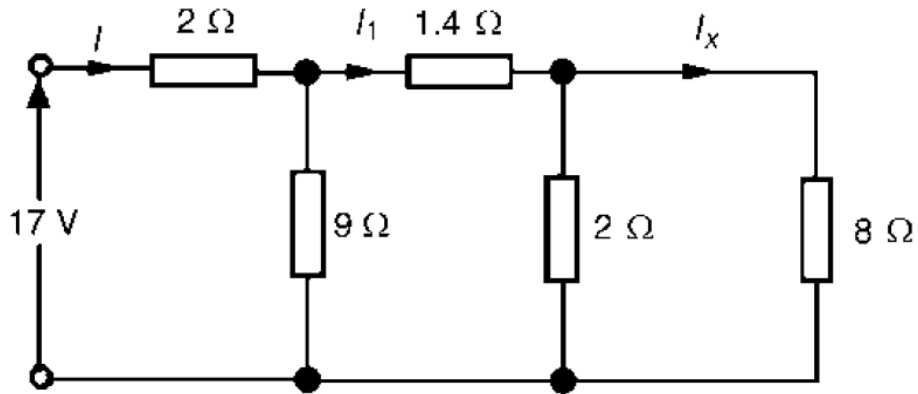

12. Four resistances of  $16\Omega$  each are connected in parallel. Four such combinations are connected in series. What is the total resistance?
13. A battery of  $9\text{ V}$  is connected in series with resistors of  $0.2\Omega$ ,  $0.3\Omega$ ,  $0.4\Omega$ ,  $0.5\Omega$  and  $12\Omega$ . How much current would flow through the  $12\Omega$  resistor?
14. An electric bulb of resistance  $20\Omega$  and a resistance wire of  $4\Omega$  are connected in series with a  $6\text{V}$  battery. Draw the circuit diagram and calculate: (a) total resistance of the circuit (b) current through the circuit (c) potential difference across the electric bulb (d) potential difference across the resistance wire.
15. Find the equivalent resistance of the given circuit.

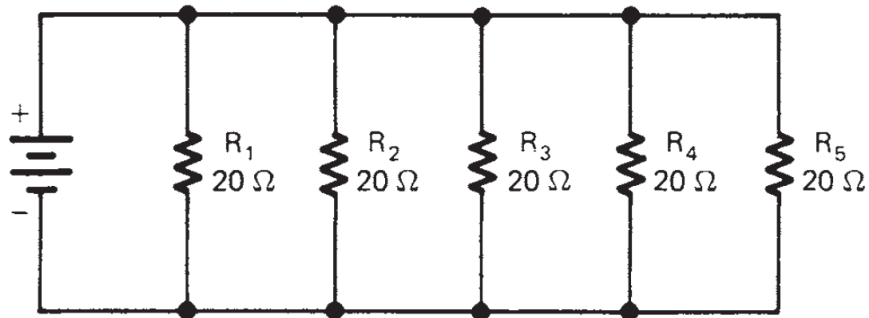

16. Find the value of  $V_T$  in the given circuit.

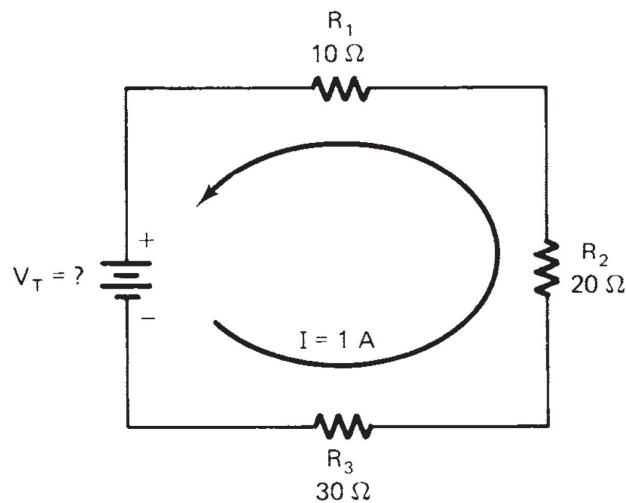

17. Find the voltage across each resistance in the given circuit.

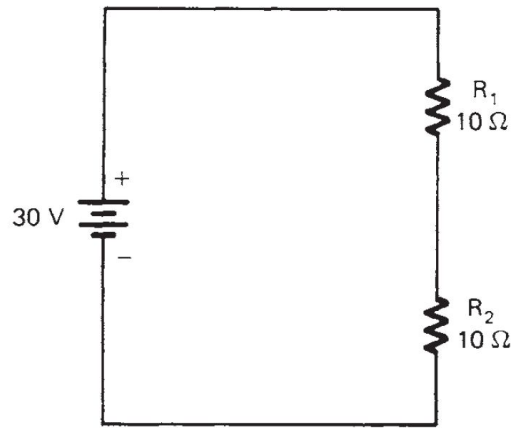

18. A potential difference of 4V is applied to two resistors of  $6\ \Omega$  and  $2\ \Omega$  connected in series. Calculate: (a) the combined resistance (b) the current flowing (c) the potential difference across the  $6\ \Omega$  resistor
19. Resistors of  $20\ \Omega$ ,  $20\ \Omega$  and  $30\ \Omega$  are connected in parallel. What resistance must be added in series with the combination to obtain a total resistance of  $10\ \Omega$ .
20. If four identical lamps are connected in parallel and the combined resistance is  $100\ \Omega$ , find the resistance of one lamp.
21. Find the current across the each resistance and total current flowing in the given circuit.

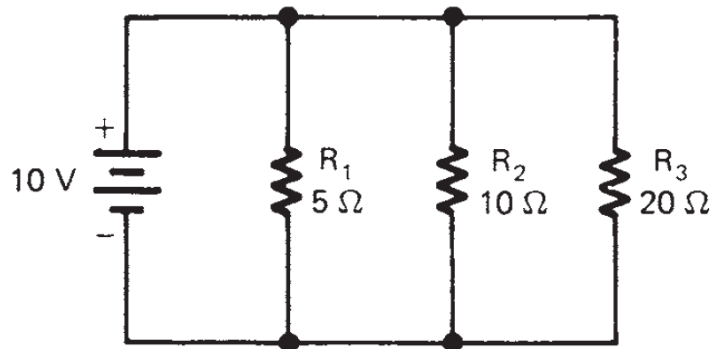

22. In the given circuit, the resistance  $R_1$  and  $R_2$  are connected in parallel. (i) Find the value of  $V_T$ . (ii) Find the total current and equivalent resistance in the circuit if resistance  $R_2 = 10\ \Omega$

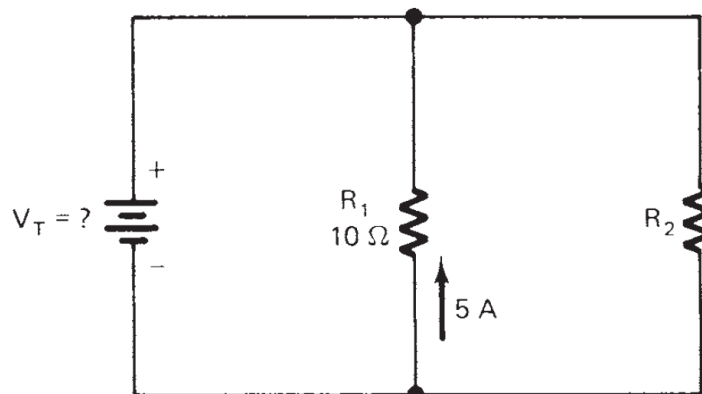

23. In the given circuit, (i) find the equivalent resistance of the circuit and total current flowing in the circuit. (ii) find the current flowing through  $R_2$  and  $R_3$ . (iii) find the voltage across each resistance.

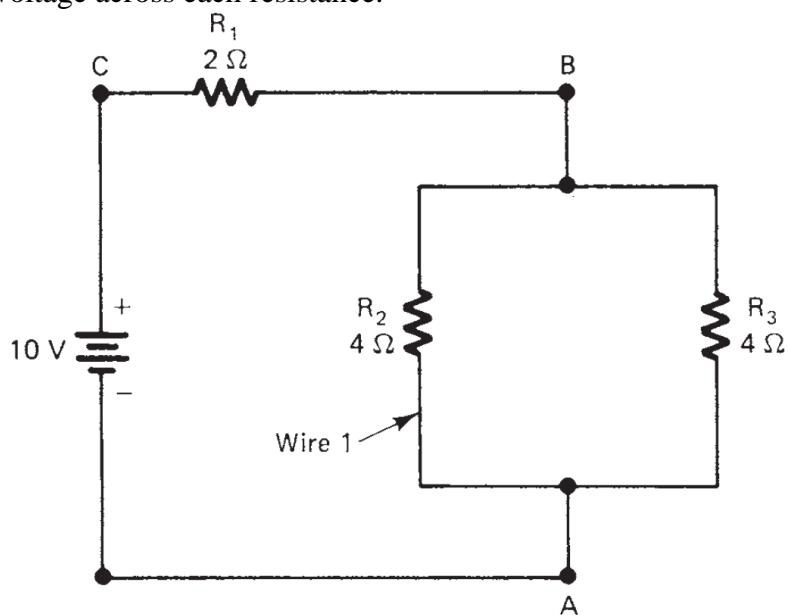

24. In the given circuit, (i) find the equivalent resistance and total current flowing in the circuit. (ii) find the voltage and current across each resistance in the circuit.

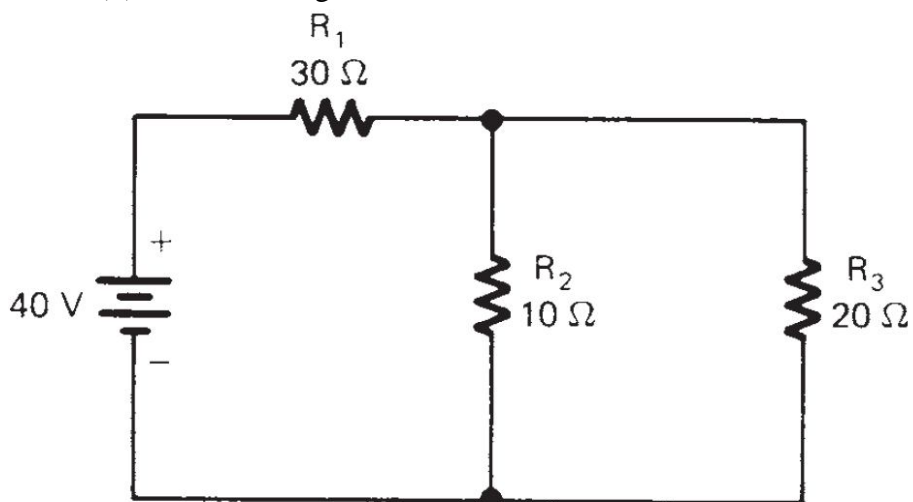

25. In the given circuit, (i) find the equivalent resistance and total current flowing in the circuit. (ii) find the voltage and current across each resistance in the circuit.

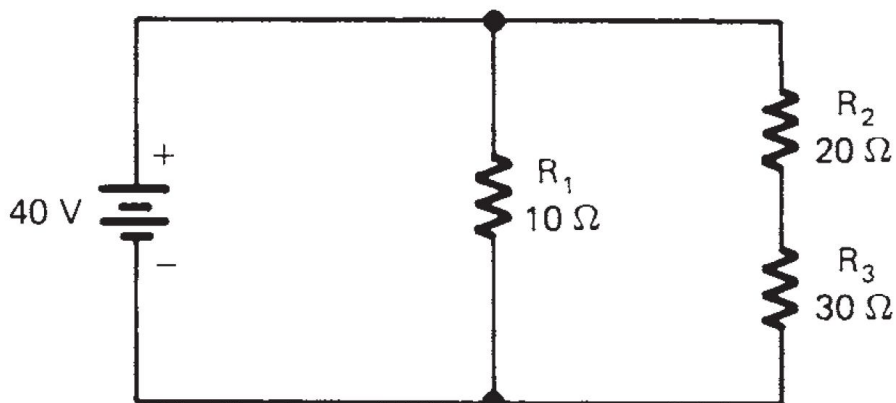

26. Find the current through 10 ohm resistor for the following circuit.

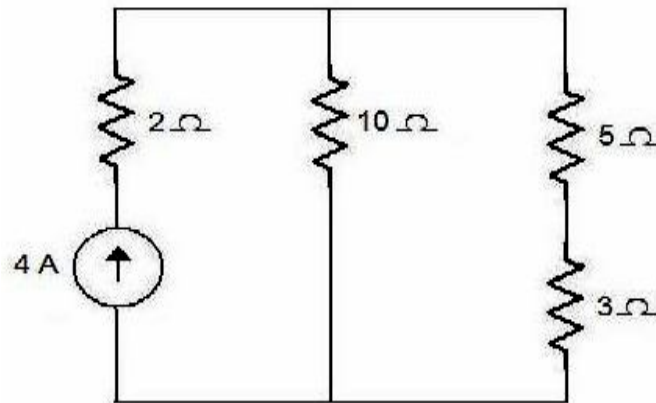

27. In the given circuit, (i) find the equivalent resistance and total current flowing in the circuit. (ii) find the voltage and current across each resistance in the circuit.

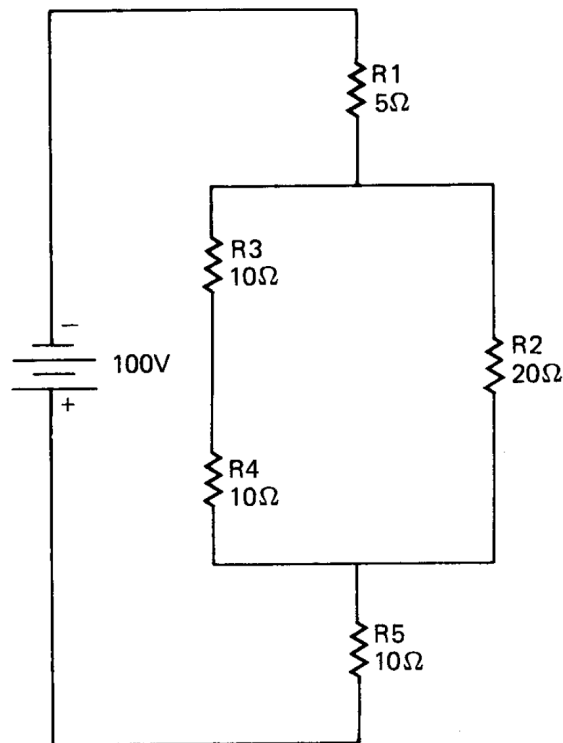

28. Find the equivalent resistance of the following circuits:

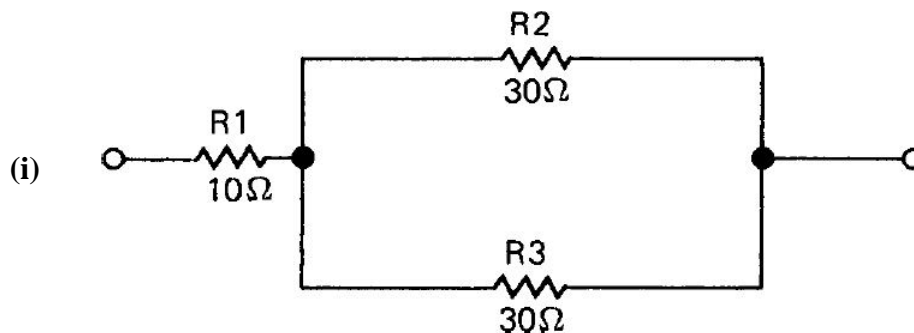

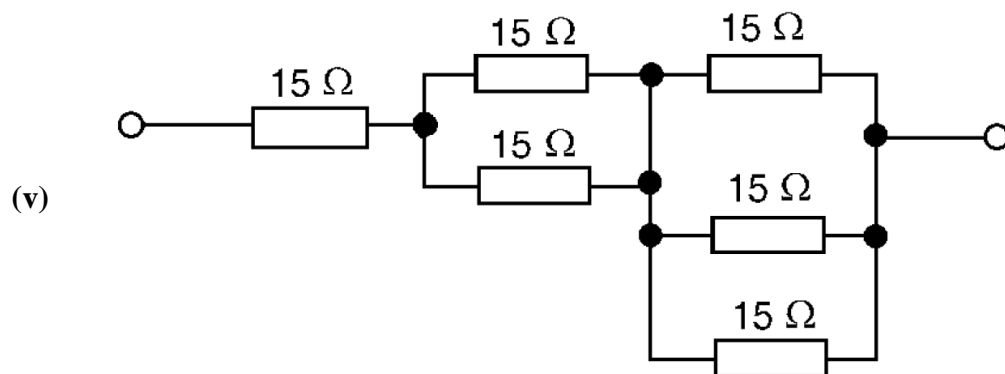
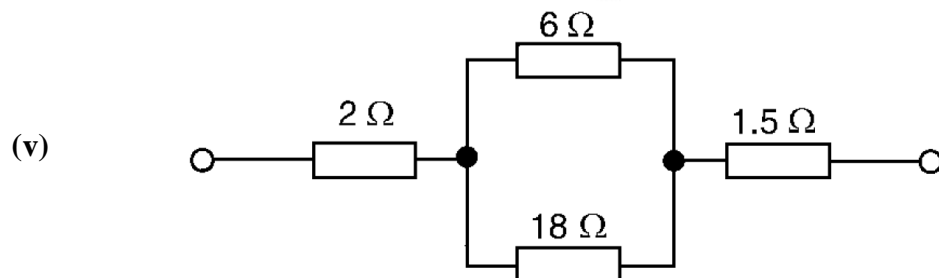
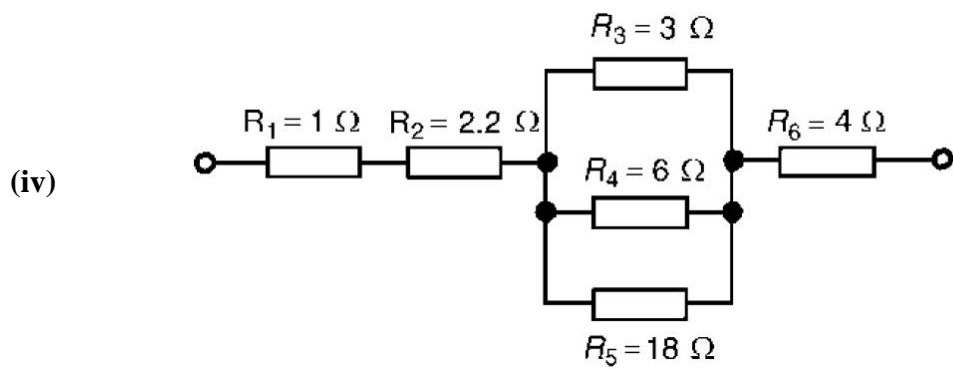
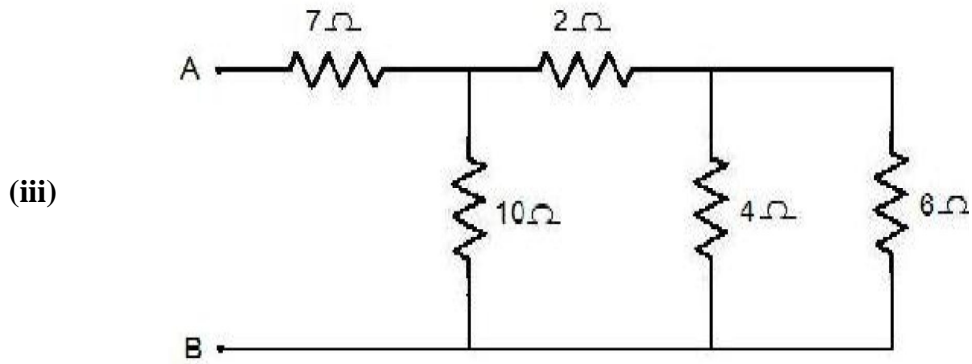
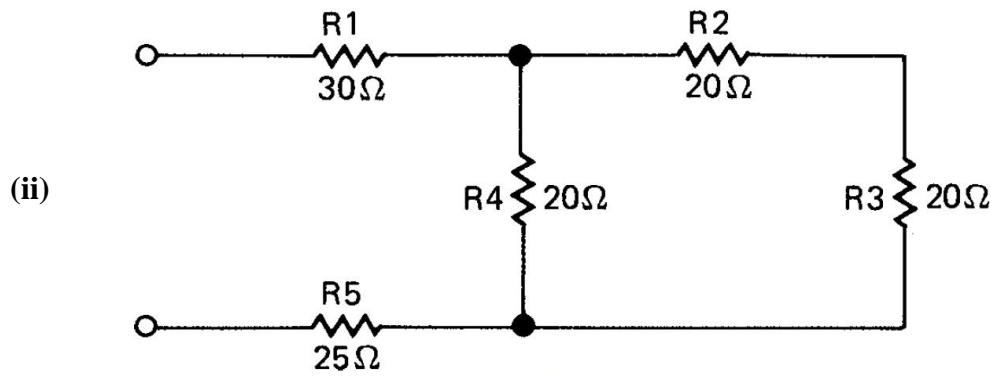

29. For the circuit shown in below Figure, determine the value of  $V_1$ . If the total circuit resistance is  $36\Omega$ , determine the supply current and the value of resistors  $R_1$ ,  $R_2$  and  $R_3$ .

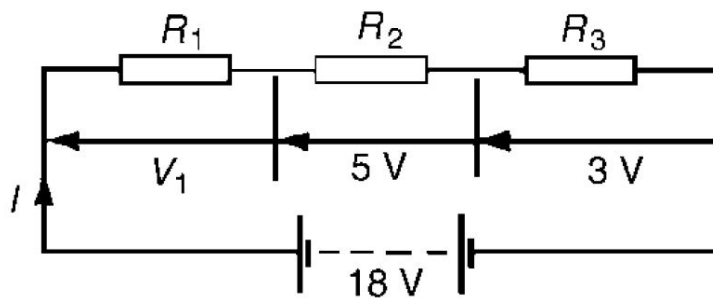

30. When the switch in the circuit in below Figure is closed the reading on voltmeter 1 is 30 V and that on voltmeter 2 is 10 V. Determine the reading on the ammeter and the value of resistor  $R_x$ .

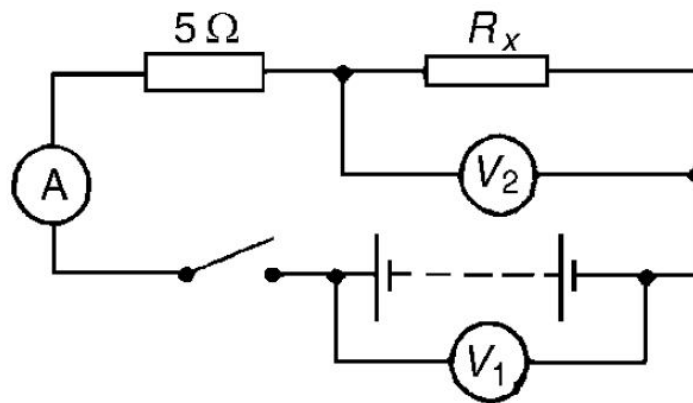

31. A potential difference of 6V is applied to two resistors of  $3\Omega$  and  $6\Omega$  connected in parallel. Calculate: (a) the combined resistance (b) the current flowing in the main circuit (c) the current flowing in the  $3\Omega$  resistor.

32. Three resistors are connected as shown in the diagram:

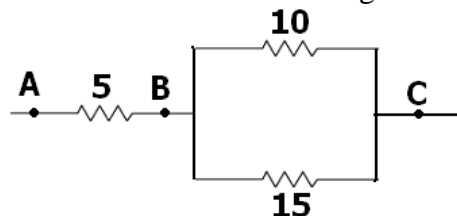

Through the resistor  $5\Omega$  ohm, a current of 1A is flowing.

- What is the current through the other two resistors?
  - What is the p.d. across AB and across AC?
  - What is the total resistance?
33. For the circuit shown in the diagram below:

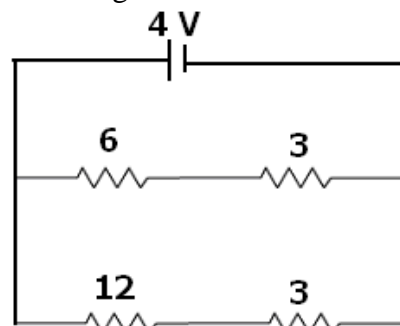

What is the value of: (i) current through  $6\Omega$  resistor? (ii) p.d. across  $12\Omega$  resistor?

34. Calculate the total resistance of the circuit below, as seen by the voltage source.

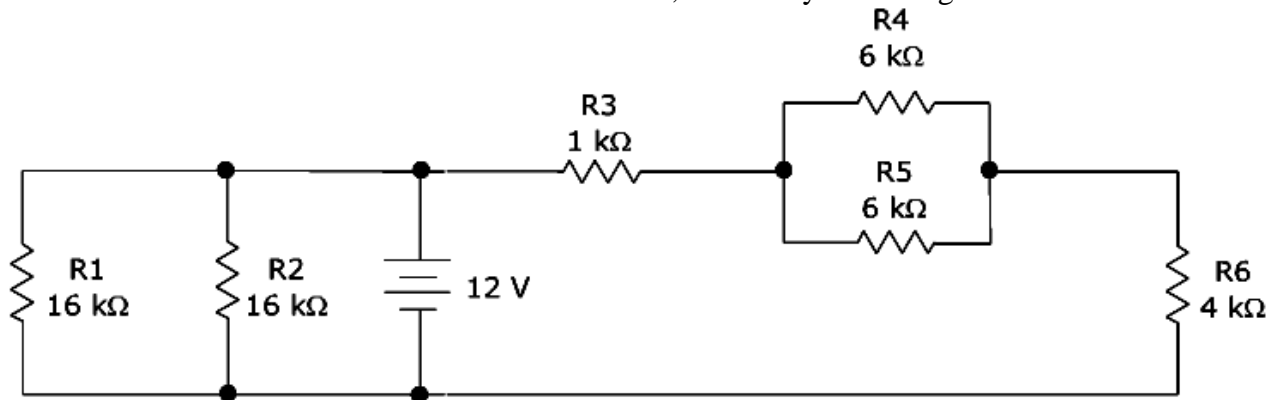

35. What is the resistance between A and B in the given figure given below?

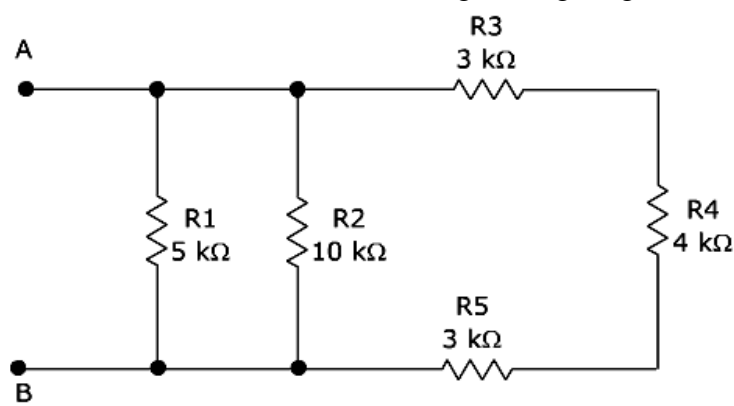

36. What is the resistance between A and B in the given figure given below?

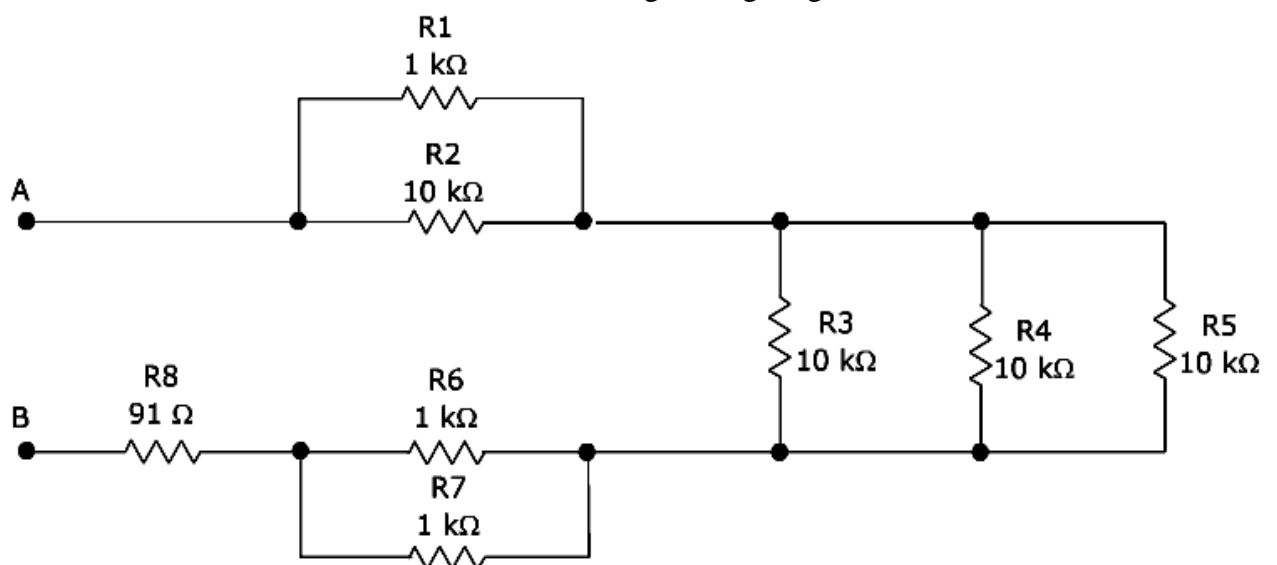

37. Resistances of  $4\Omega$  and  $12\Omega$  are connected in parallel across a  $9\text{ V}$  battery. Determine (a) the equivalent circuit resistance, (b) the supply current, and (c) the current in each resistor.

38. Three identical lamps A, B and C are connected in series across a  $150\text{ V}$  supply. State (a) the voltage across each lamp, and (b) the effect of lamp C failing.

39. The p.d's measured across three resistors connected in series are 5 V, 7 V and 10 V, and the supply current is 2 A. Determine (a) the supply voltage, (b) the total circuit resistance and (c) the values of the three resistors.
40. If three identical lamps are connected in parallel and the combined resistance is  $150\Omega$ , find the resistance of one lamp.

### HEATING EFFECT OF ELECTRIC CURRENT

If the electric circuit is purely resistive, that is, a configuration of resistors only connected to a battery; the source energy continually gets dissipated entirely in the form of heat. This is known as the heating effect of electric current. This effect is utilised in devices such as electric heater, electric iron etc

Workdone,  $W = Q \times V$

$$I = \frac{Q}{t} \Rightarrow Q = I \times t$$

$$R = \frac{V}{I} \Rightarrow V = I \times R$$

$$\therefore W = I \times t \times I \times R$$

$$\Rightarrow W = I^2 \times R \times t$$

$$\therefore \text{Heat produced, } H = I^2 \times R \times t \text{ joules}$$

This is known as Joule's law of heating.

The law implies that heat produced in a resistor is (i) directly proportional to the square of current for a given resistance ( $I^2$ ), (ii) directly proportional to resistance for a given current (R), and (iii) directly proportional to the time for which the current flows through the resistor (t).

### INTEXT QUESTIONS PAGE NO. 218

1. **Why does the cord of an electric heater not glow while the heating element does?**

**Ans.** The heating element of an electric heater is a resistor. The amount of heat produced by it is proportional to its resistance. The resistance of the element of an electric heater is very high. As current flows through the heating element, it becomes too hot and glows red. On the other hand, the resistance of the cord is low. It does not become red when current flows through it.

2. **Compute the heat generated while transferring 96000 coulomb of charge in one hour through a potential difference of 50 V.**

**Ans.** The amount of heat ( $H$ ) produced is given by the Joule's law of heating as  $H = VIt$

Where, Voltage,  $V = 50$  V, Time,  $t = 1$  h =  $1 \times 60 \times 60$  s

$$\text{Amount of current, } I = \frac{\text{Amount of Charge}}{\text{Time of flow of charge}} = \frac{96000}{1 \times 60 \times 60} = \frac{80}{3} \text{ A}$$

$$H = 50 \times \frac{80}{3} \times 60 \times 60 = 4.8 \times 10^6 \text{ J}$$

Therefore, the heat generated is  $4.8 \times 10^6 \text{ J}$



**3. An electric iron of resistance 20 Ω takes a current of 5 A. Calculate the heat developed in 30 s.**

**Ans.** The amount of heat ( $H$ ) produced is given by the Joule's law of heating as

$$H=VI t$$

Where,

$$\text{Current, } I = 5 \text{ A}$$

$$\text{Time, } t = 30 \text{ s}$$

$$\text{Voltage, } V = \text{Current} \times \text{Resistance} = 5 \times 20 = 100 \text{ V}$$

$$H = 100 \times 5 \times 30 = 1.5 \times 10^4 \text{ J}$$

Therefore, the amount of heat developed in the electric iron is  $1.5 \times 10^4 \text{ J}$

## **Practical Applications of Heating Effect of Electric Current**

The flowing of current through conductor produce heat. We are using this heat due to flow of current in our daily life as in electric iron, electric bulb, electric fuse, electric heater and more. Heating effect of electric current are below

(i) Electric iron: In an iron the upper part is grooved. In this groove a coil is placed. Mica as an insulator is placed between the metal part and the coil, so that there is no electrical connection between them. Mica is a bad conductor of electricity but it is a good conductor of heat. Due to the flow of current through the coil it becomes heated and the heat transferred to the metal part through mica. Finally the metal part becomes heated. Iron is used with the heating effect of an electric current.

(ii) Electric bulb: we see a thick metallic wire in the bulb. It is made of tungsten metal. In a glass vessel or bulb the tungsten wire is kept sealed. The glass bulb is filled with neutral gas or vacuum. Neutral gases are using now a days commonly. The tungsten wire is known as filament when the current flows through the tungsten wire or filament it becomes heated and emit of light. Due to the flow of current heating effect of an electric current used as the source of light.

(iii) Electric heater: In an electric heater one type of coil is used. A high resistance material like nichrome or same type of material is used as coil. The coil is wound in grooves on ceramic format or china clay. Flowing electric current through the coil it becomes heated. Due to high resistance the coil becomes red color forms.

(iv) Electric fuse: It protects circuits and appliances by stopping the flow of any unduly high electric current. The fuse is placed in series with the device. It consists of a piece of wire made of a metal or an alloy of appropriate melting point, for example aluminium, copper, iron, lead etc. If a current larger than the specified value flows through the circuit, the temperature of the fuse wire increases. This melts the fuse wire and breaks the circuit. The fuse wire is usually encased in a cartridge of porcelain or similar material with metal ends. The fuses used for domestic purposes are rated as 1 A, 2 A, 3 A, 5 A, 10 A, etc. For an electric iron which consumes 1 kW electric power when operated at 220 V, a current of  $(1000/220) \text{ A}$ , that is, 4.54 A will flow in the circuit. In this case, a 5 A fuse must be used.

**Electric Power:** It is the electrical work done per unit time.

$$P = \frac{W}{t}$$

where  $W$  = work done and  $t$  = time

S.I. unit of power is watt

If  $W = 1$  joule,  $t = 1$  second then  $Power = \frac{1 \text{ joule}}{1 \text{ second}} = 1 \text{ watt}$

**One watt:** The rate of working of 1 joule per second is the power of 1 watt.

**Electric Energy:** It is the total work done by a current in an electric circuit.

$$Electric \text{ power} = \frac{\text{work done by electric circuit}}{\text{time taken}}$$

Work done by electric circuit = Electric Power x time taken

$$\Rightarrow E = P \times t$$

The electrical energy consumed by an electrical appliance is given by the product of its power rating and the time for which it is used.

Unit of Electrical consumed is watt-hour(Wh)

If  $P = 1$  watt,  $t = 1$  hr, then  $E = 1$  watt x 1 hr = 1 watt-hour.

**One watt-hour:** It is the amount of electrical energy consumed when an electrical appliance of 1 watt power is used for an hour.

Commercial unit of Electrical energy is **kilowatt-hour(KWh)**

**One Kilowatt-hour:** It is the amount of electrical energy consumed when an electrical appliance having a power rating of 1 kilowatt is used in 1 hour.

$$1 \text{ kilowatt-hour} = 36,00,000 \text{ joules or } 3.6 \times 10^6 \text{ J}$$

### **INTEXT QUESTIONS PAGE NO. 220**

**1. What determines the rate at which energy is delivered by a current?**

**Ans.** The rate of consumption of electric energy in an electric appliance is called electric power. Hence, the rate at which energy is delivered by a current is the power of the appliance.

**2. An electric motor takes 5 A from a 220 V line. Determine the power of the motor and the energy consumed in 2 h.**

**Ans.** Power ( $P$ ) is given by the expression,  $P = VI$

Where,

Voltage,  $V = 220$  V

Current,  $I = 5$  A

$$P = 220 \times 5 = 1100 \text{ W}$$

Energy consumed by the motor =  $Pt$

Where,

Time,  $t = 2 \text{ h} = 2 \times 60 \times 60 = 7200 \text{ s}$

$$\therefore P = 1100 \times 7200 = 7.92 \times 10^6 \text{ J}$$

Therefore, power of the motor = 1100 W

Energy consumed by the motor =  $7.92 \times 10^6 \text{ J}$

### **NUMERICAL PROBLEMS**

1. What will be the current drawn by an electric bulb of 40 W when it is connected to a source of 220V?
2. A bulb is rated as 250V;0.4A. Find its power and resistance.
3. An electric bulb is connected to a 220V power supply line. If the bulb draw a current of 0.5A, calculate the power of the bulb.
4. An electric bulb is connected to a 250 V generator. The current is 0.50 A. What is the power of the bulb?

5. What current will be taken by a 920W appliance if the supply voltage is 230V?
6. When an electric lamp is connected to 12V battery, it draws a current 0.5A. Find the power of the lamp.
7. Calculate the power used in  $2\Omega$  resistor in each (i) a 6V battery in series with  $1\Omega$  and  $2\Omega$  resistor (ii) a 4V battery in parallel with  $12\Omega$  and  $2\Omega$  resistor.
8. A 100 W electric light bulb is connected to a 250 V supply. Determine (a) the current flowing in the bulb, and (b) the resistance of the bulb.
9. Calculate the power dissipated when a current of 4 mA flows through a resistance of  $5\text{ k}\Omega$
10. An electric kettle has a resistance of  $30\Omega$ . What current will flow when it is connected to a 240 V supply? Find also the power rating of the kettle.
11. A current of 5 A flows in the winding of an electric motor, the resistance of the winding being  $100\Omega$ . Determine (a) the p.d. across the winding, and (b) the power dissipated by the coil.
12. The current/voltage relationship for two resistors A and B is as shown in below Figure. Determine the value of the resistance of each resistor and also find the power dissipated through each resistor.

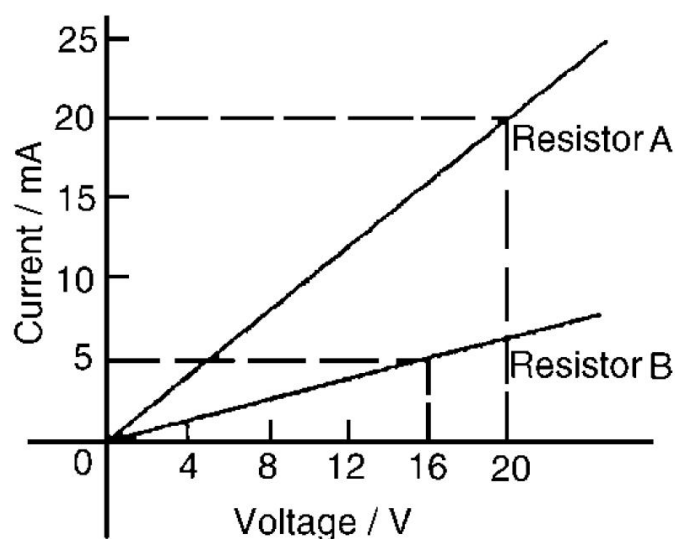

13. The hot resistance of a 240 V filament lamp is  $960\Omega$ . Find the current taken by the lamp and its power rating.
14. A 12 V battery is connected across a load having a resistance of  $40\Omega$ . Determine the current flowing in the load, the power consumed and the energy dissipated in 2 minutes.
15. A source of e.m.f. of 15 V supplies a current of 2 A for six minutes. How much energy is provided in this time?

16. Electrical equipment in an office takes a current of 13 A from a 240 V supply. Estimate the cost per week of electricity if the equipment is used for 30 hours each week and 1 kWh of energy costs 7p
17. An electric heater consumes 3.6 MJ when connected to a 250 V supply for 40 minutes. Find the power rating of the heater and the current taken from the supply.
18. Determine the power dissipated by the element of an electric fire of resistance  $20\Omega$  when a current of 10 A flows through it. If the fire is on for 6 hours determine the energy used and the cost if 1 unit of electricity costs 7p.
19. A business uses two 3 kW fires for an average of 20 hours each per week, and six 150 W lights for 30 hours each per week. If the cost of electricity is 7p per unit, determine the weekly cost of electricity to the business.
20. If 5 A, 10 A and 13 A fuses are available, state which is most appropriate for the following appliances which are both connected to a 240 V supply (a) Electric toaster having a power rating of 1 kW (b) Electric fire having a power rating of 3 kW
21. The hot resistance of a 250 V filament lamp is  $625\ \Omega$ . Determine the current taken by the lamp and its power rating.
22. Determine the resistance of a coil connected to a 150 V supply when a current of (a) 75 mA (b)  $300\ \mu\text{A}$  flows through it. Determine the power dissipated through it.
23. Determine the resistance of an electric fire which takes a current of 12A from a 240 V supply. Find also the power rating of the fire and the energy used in 20 h.
24. Determine the power dissipated when a current of 10 mA flows through an appliance having a resistance of 8 k.
25. 85.5 J of energy are converted into heat in nine seconds. What power is dissipated?
26. A current of 4 A flows through a conductor and 10 W is dissipated. What p.d. exists across the ends of the conductor?
27. Find the power dissipated when:
- (a) a current of 5 mA flows through a resistance of 20 k
  - (b) a voltage of 400 V is applied across a 120 k resistor
  - (c) a voltage applied to a resistor is 10 kV and the current flow is 4 mA.
28. A battery of e.m.f. 15 V supplies a current of 2 A for 5 min. How much energy is supplied in this time?

29. In a household during a particular week three 2 kW fires are used on average 25 h each and eight 100 W light bulbs are used on average 35 h each. Determine the cost of electricity for the week if 1 unit of electricity costs 7p.
30. Calculate the power dissipated by the element of an electric fire of resistance 30  $\Omega$  when a current of 10 A flows in it. If the fire is on for 30 hours in a week determine the energy used. Determine also the weekly cost of energy if electricity costs 7.2p per unit.
31. A television set having a power rating of 120 W and electric lawnmower of power rating 1 kW are both connected to a 240 V supply. If 3 A, 5 A and 10 A fuses are available state which is the most appropriate for each appliance.
32. For a heater rated at 4kW and 220V, calculate: (a) the current (b) the resistance of the heater (c) the energy consumed in 2 hours and (d) the cost if 1kWh is priced at Rs. 4.60
33. A radio set of 60W runs for 50hrs. How much electrical energy consumed?
34. A current of 4A flows through a 12V car headlight bulb for 10min. How much energy transfer occurs during this time?
35. Calculate the energy transferred by a 5A current flowing through a resistor of 2 $\Omega$  for 30min.
36. A bulb is rated at 200V-100W. What is its resistance? 5 such bulbs burn for 4 hrs. What is the electrical energy consumed? Calculate the cost if the rate is Rs. 4.60 per unit.
37. A refrigerator having a power rating of 350W operates for 10hours a day. Calculate the cost of electrical energy to operate it for a month of 30days. The rate of electrical energy is Rs. 3.40 per KWh.
38. What will be the current drawn by an electric bulb of 40W when it is connected to a source of 220V?
39. An electric bulb is rated 220V and 100W. When it is operated on 110V, find the power consumed.
40. An electric heater draws a current of 10A from a 220V supply. What is the cost of using the heater for 5 hrs everyday for 30days if the cost of 1 unit is Rs. 5.20?
41. In house two 60W electric bulbs are lighted for 4 hrs and three 100W bulbs for 5 hrs everyday. Calculate the electrical energy consumed in 30days.
42. An electric motor takes 5A current from a 220V supply line. Calculate the power of the motor and electrical energy consumed by it in 2 hrs.

43. An electric iron consumes energy at a rate of 840 W when heating is at the maximum rate and 360 W when the heating is at the minimum. The voltage is 220 V. What are the current and the resistance in each case?
44. An electric refrigerator rated 400 W operates 8 hour/day. What is the cost of the energy to operate it for 30 days at Rs 3.00 per kW h?
45. An electric motor takes 5 A from a 220 V line. Determine the power of the motor and the energy consumed in 2 h.
46. Two lamps, one rated 100 W at 220 V, and the other 60 W at 220 V, are connected in parallel to electric mains supply. What current is drawn from the line if the supply voltage is 220 V?
47. Which uses more energy, a 250 W TV set in 1 hr, or a 1200 W toaster in 10 minutes?
48. Two bulbs A and B are rated 100W – 120V and 10W – 120V respectively. They are connected across a 120V source in series. Which will consume more energy.
49. Two bulbs A and B are rated 100W – 120V and 10W – 120V respectively. They are connected across a 120V source in series. Find the current in each bulb. Which will consume more energy.
50. An electric kettle is rated at 230V, 1000W. What is the resistance of its element? What maximum current can pass through its element?
51. An electric geyser has the rating 1000W, 220V marked on it. What should be the minimum rating in whole number of a fuse wire that may be required for safe use with this geyser?
52. The mains power supply of a house is through a 5A fuse. How many 100W, 220V bulbs can be used in this house at the correct voltage?
53. An electrician puts a fuse of rating 5A in that part of domestic electrical circuit in which an electrical heater of rating 1.5kW, 220V is operating. What is likely to happen in this case and why? What change if any needs to be made/
54. Two bulbs of ratings 40W-220V and 60W-220V are connected in series and this combination is connected with a supply of 220V. Calculate the current from the supply line.
55. Two bulbs have the ratings 40W-200V and 20W-110V. What is the ratio of their resistances?
56. I can spend Rs. 9 per month (30days) on electric light. If power is 30paise per kWh and I use 5 identical bulbs for 5 hours a day, what should be the power of each bulb?

57. Compute the number of electrons passing through per minute through an electric bulb of 60W, 220V.
58. If electrical energy costs Rs.3 per unit, what is the total cost of leaving 4 light bulb rated at 100W each switched on for 8 hours.
59. An electric heater of resistance  $8\Omega$  draws 15 A from the service mains 2 hours. Calculate the rate at which heat is developed in the heater.
60. 100 J of heat are produced each second in a  $4\Omega$  resistance. Find the potential difference across the resistor.
61. Compute the heat generated while transferring 96000 coulomb of charge in one hour through a potential difference of 50 V.
62. An electric iron of resistance  $20\Omega$  takes a current of 5 A. Calculate the heat developed in 30 s.
63. A p.d. of 250V is applied across a resistance of  $500\Omega$  in an electric iron. Calculate (i) current (ii) heat energy produced in joules in 10s.
64. Calculate the heat produced when 96000C of charge is transferred in 1 hour through a p.d. of 50V.
65. A resistance of  $40\Omega$  and one of  $60\Omega$  are arranged in series across 220V supply. Find the heat in joules produced by this combination of resistances in half a minute?
66. When a current of 4A passes through a certain resistor for 10min,  $2.88 \times 10^4$  J of heat are produced. Calculate (a) power of the resistor (b) the voltage across the resistor.
67. A heating coil has a resistance of  $200\Omega$ . At what rate will heat be produced in it when a current of 2.5 A flows through it.
68. An electric heater of resistance  $8\Omega$  takes a current of 15A from the mains supply line. Calculate the rate at which heat is developed in the heater.
69. A resistance of  $25\Omega$  is connected to a 12V battery. Calculate the heat energy in joule generated per minute.
70. How much heat will an instrument of 12W produce in one minute if its is connected to a battery of 12V?

### **EXERCISE QUESTIONS PAGE NO. 221**

1. A piece of wire of resistance  $R$  is cut into five equal parts. These parts are then connected in parallel. If the equivalent resistance of this combination is  $R'$ , then the ratio  $R/R'$  is – (a)  $\frac{1}{25}$  (b)  $\frac{1}{5}$  (c) 5 (d) 25

**Ans.** (d) Resistance of a piece of wire is proportional to its length. A piece of wire has a resistance  $R$ . The wire is cut into five equal parts.

Therefore, resistance of each part =  $\frac{R}{5}$

All the five parts are connected in parallel. Hence, equivalent resistance ( $R'$ ) is given as

$$\frac{1}{R'} = \frac{5}{R} + \frac{5}{R} + \frac{5}{R} + \frac{5}{R} + \frac{5}{R} = \frac{5+5+5+5+5}{R} = \frac{25}{R}$$

$$\frac{1}{R'} = \frac{25}{R} \Rightarrow \frac{R}{R'} = 25$$

Therefore, the ratio  $\frac{R}{R'}$  is 25.

2. Which of the following terms does not represent electrical power in a circuit?

(a)  $I^2R$  (b)  $IR^2$  (c)  $VI$  (d)  $V^2/R$

**Ans.** (b) Electrical power is given by the expression,  $P = VI$  ... (i)

According to Ohm's law,  $V = IR$  ... (ii)

where,  $V$  = Potential difference,  $I$  = Current and  $R$  = Resistance

$$\therefore P = VI$$

From equation (i), it can be written

$$P = (IR) \times I$$

$$\therefore P = I^2R$$

From equation (ii), it can be written

$$I = \frac{V}{R}$$

$$\therefore P = V \times \frac{V}{R} \Rightarrow P = \frac{V^2}{R}$$

$$\therefore P = VI = I^2R = \frac{V^2}{R}$$

Power  $P$  cannot be expressed as  $IR^2$ .

3. An electric bulb is rated 220 V and 100 W. When it is operated on 110 V, the power consumed will be – (a) 100 W (b) 75 W (c) 50 W (d) 25 W

**Ans.** (d) Energy consumed by an appliance is given by the expression,

$$P = VI = \frac{V^2}{R}$$

$$\Rightarrow R = \frac{V^2}{P}$$

where, Power rating,  $P = 100$  W, Voltage,  $V = 220$  V

$$\text{Resistance, } R = \frac{(220)^2}{100} = 484\Omega$$

The resistance of the bulb remains constant if the supply voltage is reduced to 110 V. If the bulb is operated on 110 V, then the energy consumed by it is given by the expression for power as

$$\therefore P' = \frac{(V')^2}{R} = \frac{(110)^2}{484} = 25W$$

Therefore, the power consumed will be 25 W.



4. Two conducting wires of the same material and of equal lengths and equal diameters are first connected in series and then parallel in a circuit across the same potential difference. The ratio of heat produced in series and parallel combinations would be – (a) 1:2 (b) 2:1 (c) 1:4 (d) 4:1

**Ans.** (c) The Joule heating is given by,  $H = i^2 R t$

Let,  $R$  be the resistance of the two wires.

The equivalent resistance of the series connection is  $R_s = R + R = 2R$

If  $V$  is the applied potential difference, then it is the voltage across the equivalent resistance.

$$V = I_s \times 2R$$

$$\Rightarrow I_s = \frac{V}{2R}$$

The heat dissipated in time  $t$  is,

$$H = I_s^2 \times 2R \times t = \left(\frac{V}{2R}\right)^2 \times 2R \times t \Rightarrow H = \frac{V^2 t}{2R}$$

The equivalent resistance of the parallel connection is  $R_p = \frac{1}{\frac{1}{R} + \frac{1}{R}} = \frac{R}{2}$

$V$  is the applied potential difference across this  $R_p$ .

$$V = I_p \times \frac{R}{2}$$

$$\Rightarrow I_p = \frac{2V}{R}$$

The heat dissipated in time  $t$  is,

$$H' = I_p^2 \times \frac{R}{2} \times t = \left(\frac{2V}{R}\right)^2 \times \frac{R}{2} \times t \Rightarrow H' = \frac{2V^2 t}{R}$$

So, the ratio of heat produced is,  $\frac{H}{H'} = \frac{\frac{V^2 t}{2R}}{\frac{2V^2 t}{R}} = \frac{1}{4}$

5. How is a voltmeter connected in the circuit to measure the potential difference between two points?

**Ans.** To measure the potential difference between two points, a voltmeter should be connected in parallel to the points.

6. A copper wire has diameter 0.5 mm and resistivity of  $1.6 \times 10^{-8} \Omega m$ . What will be the length of this wire to make its resistance  $10 \Omega$ ? How much does the resistance change if the diameter is doubled?

**Ans.** Resistance ( $R$ ) of a copper wire of length  $l$  and cross-section  $A$  is given by the expression,

$$R = \rho \frac{l}{A}$$

Where,

Resistivity of copper,  $\rho = 1.6 \times 10^{-8} \Omega m$

Area of cross-section of the wire,  $A = \pi \left(\frac{\text{diameter}}{2}\right)^2$

Diameter = 0.5 mm = 0.0005 m

Resistance,  $R = 10 \Omega$

Hence, length of the wire,

$$l = \frac{RA}{\rho} = \frac{10 \times 3.14 \times \left(\frac{0.0005}{2}\right)^2}{1.6 \times 10^{-8}} = \frac{10 \times 3.14 \times 25}{4 \times 1.6} = 122.72 \text{ m}$$

If the diameter of the wire is doubled, new diameter =  $2 \times 0.5 = 1 \text{ mm} = 0.001 \text{ m}$

Therefore, resistance  $R'$

$$R' = \rho \frac{l}{A} = \frac{1.6 \times 10^{-8} \times 122.72}{\pi \left(\frac{1}{2} \times 10^{-3}\right)^2}$$

$$\Rightarrow R' = \frac{1.6 \times 10^{-8} \times 122.72 \times 4}{3.14 \times 10^{-6}} = 250.2 \times 10^{-2} = 2.5 \Omega$$

Therefore, the length of the wire is 122.7 m and the new resistance is 2.5  $\Omega$

7. The values of current  $I$  flowing in a given resistor for the corresponding values of potential difference  $V$  across the resistor are given below –

$I$ (amperes)	0.5	1.0	2.0	3.0	4.0
$V$ (volts)	1.6	3.4	6.7	10.2	13.2

Plot a graph between  $V$  and  $I$  and calculate the resistance of that resistor.

**Ans.** The plot between voltage and current is called  $IV$  characteristic. The voltage is plotted on  $x$ -axis and current is plotted on  $y$ -axis.

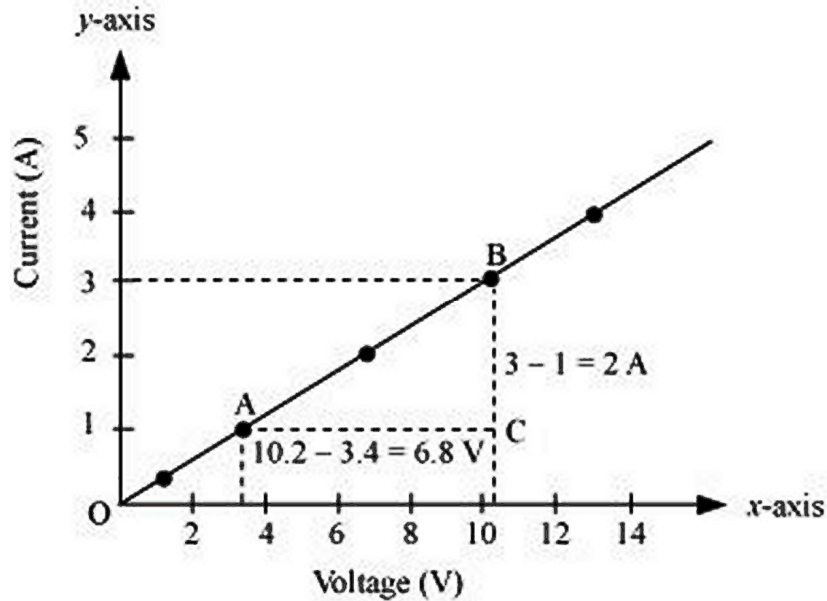

The slope of the line gives the value of resistance ( $R$ ) as,

$$\text{Slope} = \frac{1}{R} = \frac{BC}{AC} = \frac{2}{6.8} \Rightarrow R = \frac{6.8}{2} = 3.4 \Omega$$

Therefore, the resistance of the resistor is 3.4  $\Omega$

8. When a 12 V battery is connected across an unknown resistor, there is a current of 2.5 mA in the circuit. Find the value of the resistance of the resistor.

**Ans.** Resistance ( $R$ ) of a resistor is given by Ohm's law as,

$$V = IR \Rightarrow R = \frac{V}{I}$$

where, Potential difference,  $V = 12 \text{ V}$

Current in the circuit,  $I = 2.5 \text{ mA} = 2.5 \times 10^{-3} \text{ A}$

$$V = IR \Rightarrow R = \frac{12}{2.5 \times 10^{-3}} = 4.8 \times 10^3 \Omega = 4.8 k\Omega$$

Therefore, the resistance of the resistor is  $4.8 k\Omega$

9. A battery of 9 V is connected in series with resistors of  $0.2 \Omega$ ,  $0.3 \Omega$ ,  $0.4 \Omega$ ,  $0.5 \Omega$  and  $12 \Omega$ , respectively. How much current would flow through the  $12 \Omega$  resistor?

**Ans.** There is no current division occurring in a series circuit. Current flow through the component is the same, given by Ohm's law as

$$V = IR \Rightarrow I = \frac{V}{R} \text{ where, } R \text{ is the equivalent resistance of resistances } 0.2 \Omega, 0.3 \Omega,$$

$0.4 \Omega, 0.5 \Omega$  and  $12 \Omega$ . These are connected in series. Hence, the sum of the resistances will give the value of  $R$ .

$$R = 0.2 + 0.3 + 0.4 + 0.5 + 12 = 13.4 \Omega$$

Potential difference,  $V = 9 \text{ V}$

$$I = \frac{9}{13.4} = 0.671 \text{ A}$$

Therefore, the current that would flow through the  $12 \Omega$  resistor is  $0.671 \text{ A}$ .

10. How many  $176 \Omega$  resistors (in parallel) are required to carry 5 A on a 220 V line?

**Ans.** For  $x$  number of resistors of resistance  $176 \Omega$ , the equivalent resistance of the resistors connected in parallel is given by Ohm's law as

$$V = IR \Rightarrow R = \frac{V}{I}$$

where, Supply voltage,  $V = 220 \text{ V}$ , Current,  $I = 5 \text{ A}$

Equivalent resistance of the combination =  $R$ , given as

$$\frac{1}{R} = x \times \frac{1}{176} \Rightarrow R = \frac{176}{x}$$

$$\text{From Ohm's law, } \frac{V}{I} = \frac{176}{x} \Rightarrow x = \frac{176 \times I}{V} = \frac{176 \times 5}{220} = 4$$

Therefore, four resistors of  $176 \Omega$  are required to draw the given amount of current.

11. Show how you would connect three resistors, each of resistance  $6 \Omega$ , so that the combination has a resistance of (i)  $9 \Omega$ , (ii)  $4 \Omega$ .

**Ans.** If we connect the resistors in series, then the equivalent resistance will be the sum of the resistors, i.e.,  $6 \Omega + 6 \Omega + 6 \Omega = 18 \Omega$ , which is not desired. If we

connect the resistors in parallel, then the equivalent resistance will be  $\frac{6}{2} = 3\Omega$ ,

which is also not desired. Hence, we should either connect the two resistors in series or parallel.

(i) Two resistors in parallel

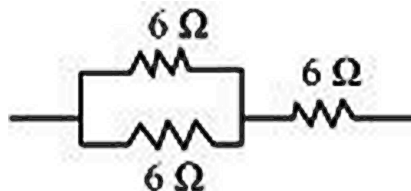

Two  $6 \Omega$  resistors are connected in parallel. Their equivalent resistance will be

$$R = \frac{1}{\frac{1}{R_1} + \frac{1}{R_2}} = \frac{1}{\frac{1}{6} + \frac{1}{6}} = \frac{6 \times 6}{6 + 6} = 3\Omega$$

The third  $6\ \Omega$  resistor is in series with  $3\ \Omega$ . Hence, the equivalent resistance of the circuit is  $6\ \Omega + 3\ \Omega = 9\ \Omega$ .

(ii) Two resistors in series

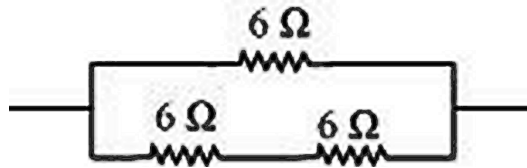

Two  $6\ \Omega$  resistors are in series. Their equivalent resistance will be the sum  $6 + 6 = 12\ \Omega$

The third  $6\ \Omega$  resistor is in parallel with  $12\ \Omega$ . Hence, equivalent resistance will be

$$R = \frac{1}{\frac{1}{R_1} + \frac{1}{R_2}} = \frac{1}{\frac{1}{12} + \frac{1}{6}} = \frac{12 \times 6}{12 + 6} = 4\ \Omega$$

Therefore, the total resistance is  $4\ \Omega$

12. Several electric bulbs designed to be used on a  $220\ \text{V}$  electric supply line, are rated  $10\ \text{W}$ . How many lamps can be connected in parallel with each other across the two wires of  $220\ \text{V}$  line if the maximum allowable current is  $5\ \text{A}$ ?

**Ans.** Resistance  $R_1$  of the bulb is given by the expression,

$$P_1 = \frac{V^2}{R_1} \Rightarrow R_1 = \frac{V^2}{P_1} \quad \text{where, Supply voltage, } V = 220\ \text{V}; \text{ Maximum allowable}$$

current,  $I = 5\ \text{A}$

Rating of an electric bulb,  $P_1 = 10\ \text{W}$

$$R_1 = \frac{(220)^2}{10} = 4840\ \Omega$$

According to Ohm's law,  $V = IR$

where,  $R$  is the total resistance of the circuit for  $x$  number of electric bulbs

$$R = \frac{V}{I} = \frac{220}{5} = 44\ \Omega$$

Resistance of each electric bulb,  $R_1 = 4840\ \Omega$

$$\frac{1}{R} = \frac{1}{R_1} + \frac{1}{R_2} + \dots \text{upto } x \text{ times} \Rightarrow \frac{1}{R} = \frac{1}{R_1} \times x$$

$$\Rightarrow x = \frac{R_1}{R} = \frac{4840}{44} = 110$$

Therefore, 110 electric bulbs are connected in parallel.

13. A hot plate of an electric oven connected to a  $220\ \text{V}$  line has two resistance coils A and B, each of  $24\ \Omega$  resistance, which may be used separately, in series, or in parallel. What are the currents in the three cases?

**Ans.** Supply voltage,  $V = 220\ \text{V}$

Resistance of one coil,  $R =$

(i) Coils are used separately

According to Ohm's law,  $V_1 = I_1 R_1$  where,  $I_1$  is the current flowing through the coil

$$I_1 = \frac{V}{R_1} = \frac{220}{24} = 9.166\ \text{A}$$

Therefore,  $9.16\ \text{A}$  current will flow through the coil when used separately.

(ii) Coils are connected in series

Total resistance,  $R_2 = 24\ \Omega + 24\ \Omega = 48\ \Omega$

According to Ohm's law,  $V_2 = I_2 R_2$  where,  $I_2$  is the current flowing through the coil

$$I_2 = \frac{V}{R_2} = \frac{220}{48} = 4.58A$$

Therefore, 4.58 A current will flow through the circuit when the coils are connected in series.

(iii) Coils are connected in parallel

$$\text{Total resistance, } R_3 = \frac{1}{\frac{1}{24} + \frac{1}{24}} = \frac{24}{2} = 12\Omega$$

According to Ohm's law,  $V_3 = I_3 R_3$  where,  $I_3$  is the current flowing through the coil

$$I_3 = \frac{V}{R_3} = \frac{220}{12} = 18.33A$$

Therefore, 18.33 A current will flow through the circuit when coils are connected in parallel.

- 14.** Compare the power used in the  $2\ \Omega$  resistor in each of the following circuits: (i) a 6 V battery in series with  $1\ \Omega$  and  $2\ \Omega$  resistors, and (ii) a 4 V battery in parallel with  $12\ \Omega$  and  $2\ \Omega$  resistors.

**Ans.** (i) Potential difference,  $V = 6\ \text{V}$

$1\ \Omega$  and  $2\ \Omega$  resistors are connected in series. Therefore, equivalent resistance of the circuit,  $R = 1 + 2 = 3\ \Omega$

According to Ohm's law,  $V = IR$  where,  $I$  is the current through the circuit

$$I = \frac{6}{3} = 2A$$

This current will flow through each component of the circuit because there is no division of current in series circuits. Hence, current flowing through the  $2\ \Omega$  resistor is 2A. Power is given by the expression,

$$P = (I)^2 R = (2)^2 \cdot 2 = 8W$$

(ii) Potential difference,  $V = 4\ \text{V}$

$12\ \Omega$  and  $2\ \Omega$  resistors are connected in parallel. The voltage across each component of a parallel circuit remains the same. Hence, the voltage across  $2\ \Omega$  resistor will be 4 V.

Power consumed by  $2\ \Omega$  resistor is given by

$$P = \frac{V^2}{R} = \frac{4^2}{2} = 8W$$

Therefore, the power used by  $2\ \Omega$  resistor is 8 W.

- 15.** Two lamps, one rated 100 W at 220 V, and the other 60 W at 220 V, are connected in parallel to electric mains supply. What current is drawn from the line if the supply voltage is 220 V?

**Ans.** Both the bulbs are connected in parallel. Therefore, potential difference across each of them will be 220 V, because no division of voltage occurs in a parallel circuit.

Current drawn by the bulb of rating 100 W is given by,

$$Power = Voltage \times Current$$

$$\Rightarrow Current = \frac{Power}{Voltage} = \frac{110}{220} A$$

Similarly, current drawn by the bulb of rating 100 W is given by,

$$Power = Voltage \times Current$$

$$\Rightarrow Current = \frac{Power}{Voltage} = \frac{60}{220} A$$

$$\text{Hence, current drawn from the line} = \frac{110}{220} + \frac{60}{220} = 0.727 A$$

- 16.** Which uses more energy, a 250 W TV set in 1 hr, or a 1200 W toaster in 10 minutes?

**Ans.** Energy consumed by an electrical appliance is given by the expression,

$$H = P \times t$$

where, Power of the appliance =  $P$ , Time =  $t$

$$\text{Energy consumed by a TV set of power 250 W in 1 h} = 250 \times 3600 = 9 \times 10^5 \text{ J}$$

$$\begin{aligned} \text{Energy consumed by a toaster of power 1200 W in 10 minutes} &= 1200 \times 600 \\ &= 7.2 \times 10^5 \text{ J} \end{aligned}$$

Therefore, the energy consumed by a 250 W TV set in 1 h is more than the energy consumed by a toaster of power 1200 W in 10 minutes.

- 17.** An electric heater of resistance  $8 \Omega$  draws 15 A from the service mains 2 hours. Calculate the rate at which heat is developed in the heater.

**Ans.** Rate of heat produced by a device is given by the expression for power as  $P = I^2 R$

where, Resistance of the electric heater,  $R = 8 \Omega$

Current drawn,  $I = 15 \text{ A}$

$$P = 15^2 \times 8 = 225 \times 8 = 1800 \text{ J/s}$$

Therefore, heat is produced by the heater at the rate of 1800 J/s.

- 18.** Explain the following.

(a) Why is the tungsten used almost exclusively for filament of electric lamps?

(b) Why are the conductors of electric heating devices, such as bread-toasters and electric irons, made of an alloy rather than a pure metal?

(c) Why is the series arrangement not used for domestic circuits?

(d) How does the resistance of a wire vary with its area of cross-section?

(e) Why are copper and aluminium wires usually employed for electricity transmission?

**Ans.** (a) The melting point and resistivity of tungsten are very high. It does not burn readily at a high temperature. The electric lamps glow at very high temperatures. Hence, tungsten is mainly used as heating element of electric bulbs.

(b) The conductors of electric heating devices such as bread toasters and electric irons are made of alloy because resistivity of an alloy is more than that of metals. It produces large amount of heat.

(c) There is voltage division in series circuits. Each component of a series circuit receives a small voltage for a large supply voltage. As a result, the amount of current decreases and the device becomes hot. Hence, series arrangement is not used in domestic circuits.

(d) Resistance ( $R$ ) of a wire is inversely proportional to its area of cross-section ( $A$ ), i.e.,  $R \propto \frac{1}{A}$

(e) Copper and aluminium wires have low resistivity. They are good conductors of electricity. Hence, they are usually employed for electricity transmission.



# ASSIGNMENT QUESTIONS

## ELECTRICITY

### VERY SHORT ANSWER TYPE QUESTIONS (1 MARK)

1. Define Electrostatic potential.
2. What is potential difference?
3. Define 1 volt.
4. Name the SI unit of potential difference.
5. Is potential difference a scalar or a vector quantity?
6. Name the instrument used to measure potential difference.
7. Does a voltmeter have a high or low resistance?
8. Write the other name of Joule/Coulomb?
9. How much work is done when one coulomb of charge moves against a potential difference of 1 volt?
10. Name the SI unit of electric current.
11. Is electric current a scalar or vector quantity?
12. Name the instrument used to measure electric current.
13. Does an ammeter have low or a high resistance?
14. Write the other name of variable resistance.
15. How do we connect an ammeter in a circuit?
16. Write the unit of electrical resistance.
17. State the factors on which the resistance of a conductor depends.
18. What is the term for the reciprocal of resistance?
19. What is the nature of the graph between I and V for a metallic conductor?
20. Does Ohm's law hold for a copper wire?



21. Does Ohm's law hold for a liquid electrolyte?
22. Does Ohm's law hold for a vacuum tube?
23. Following are the I vs V graphs for a (a) metallic conductor (b) liquid electrolyte and (c) vacuum tube. In which case does the Ohm's law hold good?
24. What do you mean by resistance?
25. Does the resistance of a metal change when we raise the temperature of the metal?
26. Name the substance having the largest and smallest electrical resistance amongst the following: Silver, copper, nichrome, rubber, acidulated water.
27. Name the best conductor of electricity.
28. Name an excellent insulator.
29. Is wood a good conductor of electricity.
30. When are two resistances said to be in series?
31. When are two resistances said to be in parallel?
32. How many different resistance-combinations are possible with two equal resistors, taking both of them together?
33. The unit of resistance is ohm. What is the unit of conductance?
34. Define electric power.
35. What is the SI unit of electrical power?
36. Name the quantity which is the product of potential difference and current.
37. Express power P in terms of I and R.
38. Write various formulae for electric power.
39. What does 220V, 100W written on an electrical appliance mean? What do you mean by power rating?

40. Which of the following electrical appliances usually has the (a) highest (b) least, power ratings? Tube light, Electric fan, Electric heater, Immersion heater.
41. Which of the following electrical appliances usually draws the (a) highest and (b) least, current when operated at 220V? Tube light, Electrical fan, Electrical heater, Immersion heater.
42. What do you mean by electrical energy being consumed by an electrical appliance?
43. Write the SI unit of electrical energy.
44. Write the commercial unit of energy.
45. Define one Kilowatt-hour.
46. Convert 1 Kwh to MJ.
47. What is the ratio of SI units to C.G.S. unit of electrical energy?
48. What are the factors on which electrical energy consumed by an electrical appliance depends?
49. What do you mean by one unit of electrical energy?
50. How many joules are in one watt-hour?
51. List some important effects of electric current.
52. Name the quantity whose role in mechanics is similar to the role of resistance in electrical circuits.
53. Write a formula for calculating the amount of heat (H) produced in a resistor of resistance R when current I is passed through it for time t.
54. List of factors on which heating effect of electric current depends.
55. How is the heat produced by a current passing through a constant resistance related to the strength of the current?
56. Name the Scientist who gave the formula for finding the heating produced in a conductor.

57. Is joule's heating a reversible effect?
58. How much can be Joule's heating produced in an ideal insulator?
59. Name three electrical appliances that involve the heating effect of electric current.
60. Is electric fuse an application of heating effect of current?
61. Out of 5A fuse and 15A fuse which will you prefer to use for the lighting circuit?
62. In domestic wiring do we connect various distribution circuits in series?
63. Usually three insulated wires of different colours are used in electrical appliance. Name the three colours.
64. What do you mean by short circuiting?
65. What do you mean by a fuse?
66. Should a fuse wire be connected in series or in parallel in the main circuit?
67. Can we use a copper wire as a fuse wire?
68. Name the instrument used to measure current in a circuit.
69. Name the instrument used to detect weak currents in a circuit.
70. Is ammeter connected in series or parallel in a circuit?
71. What does the potential of a charged body determine?
72. Is potential difference between two points in an electric field a vector quantity?
73. What does a voltmeter measure?
74. Is a voltmeter same as a voltmeter?
75. What are the conditions under which charges can move in a conductor?
76. How will you maintain a potential difference between the ends of a conductor?
77. Name the quantity that determines the rate of flow of charge through a conductor

78. What determines the direction of flow of charge: Potential of a body or Quantity of charge on a body?
79. When the two ends of copper wire are connected to the two terminals of a battery some potential difference is created between its ends. Do electrons start flowing from high potential end to low potential end?
80. In the question above, does current flow from the low potential end to the high potential end of the wire?
81. What is the difference between a cell and a battery?
82. What do you mean by an electric circuit?
83. What do you mean by a circuit diagram?
84. How does a cell maintain some constant potential difference across its terminals?
85. Do all substances have the same resistivity?
86. Give two substances having very low resistivities.
87. Give two substances having moderate resistivities.
88. Give two substances having high resistivities.
89. What is the name given to substances which are used for making heating coils?
90. Why do electricians wear rubber shoes or sandals or rubber hand gloves while working?
91. What are the two ways in which the resistances are combined?
92. What is meant by an equivalent resistance?
93. Name the SI unit of electrical energy.
94. Name the commercial unit of energy.
95. Name the property of a conductor by virtue of which it opposes the flow of electric current through it.

96. Is resistance a scalar or a vector quantity?
97. Name the property of a conductor by virtue of which it allows the flow of charge through it.
98. Is conductance a scalar or a vector quantity?
99. Which has a greater resistance: thin wire or thick wire of the same material?
100. What happens to the resistance of a copper wire when its temperature is raised?
101. What happens to the conductance of a copper wire when its temperature is raised?
102. What happens to the resistance of the following substances when its temperature is raised?  
(i) Aluminium (ii) Silicon (iii) Silver (iv) Germanium
103. Define 1KWh.
104. Name the quantity that represents the electric work done per unit time.
105. Express electric power (P) in terms of current (I) and resistance (R).
106. Express electric power (P) in terms of current (I) and potential difference (V).
107. Name the quantity that represents the product of power rating and time.
108. What voltage for the electrical appliance is kept in India?
109. What voltage is kept for the domestic electric supply in USA?
110. An electric heater is rated as 220V, 1KW. What does it mean?
111. Name the term used to represent the values of the voltage and wattage(power) of an electrical appliance taken together.
112. Which bulb has the lesser resistance: 100W or 60W?
113. Which electrical appliance generally draws more current for the same applied voltage: Electric iron or Electric bulb?
114. What do you understand by the heating effect of electric current?

115. A number of bulbs are to be connected to a single source. Will they provide more illumination if connected in parallel, or in series?
116. What do you mean by the overloading of the electrical circuit?
117. All electrical circuits consist of three wires: a live wire, a neutral wire and an earth wire, what colours are assigned to these wires?
118. What do you understand by short circuiting?
119. What will happen when the live and the neutral wires in a circuit touch each other due to defective wiring?
120. What is the use of electrical fuse in an electrical circuit?
121. Name the effect of current on which a fuse works.
122. Where do we connect a fuse in an electrical circuit?
123. By what symbol is earthing represented?
124. Why do we do the earthing of an electrical appliance?
125. What does an electric meter in the house hold electric circuit measure?
126. Are distribution circuits connected to each other in series or in parallel?
127. Are switches connected in the neutral wire?
128. What do you mean by earthing of an electrical appliance?

**SHORT ANSWER TYPE – I QUESTIONS (2 MARKS)**

1. Why can't we use a copper wire as a fuse wire?
2. What is usual colour code followed for connecting live, neutral and earth wires? Why is it so important?
3. Define Electric current. How can you measure the magnitude of electric current?
4. What is the direction of conventional current?
5. State the law, which relates the current in a conductor to the potential difference across its ends.

6. Differentiate between conductors and insulators.
7. What is the law of combination of resistances in series?
8. What is the law of combination of resistances in parallel?
9. What do you mean when we say that the electric appliance is earthed? What is its importance?
10. What causes electric resistance? What is the physical significance of resistance?
11. What are the limitations of Ohm's law? What are ohmic conductors?
12. A graph is plotted between V(potential difference) and I(current) for a metal at two different temperatures  $T_1$  and  $T_2$ . What is the relationship between  $T_1$  and  $T_2$ ?
13. How many different resistances are possible with two equal resistors?
14. Draw a diagram used for a fuse to be used in an electrical appliance. Write the symbol for an electrical fuse in circuit diagram.
15. One billion electrons pass from a point A towards another point B in  $10^{-4}$  s. What is the current in amperes? What is its direction?

**SHORT ANSWER TYPE – II QUESTIONS (3 MARKS)**

1. Given five equal resistances; each of the value 5 ohms. (a) What is the maximum resistance that can be obtained from them? (b) What is the minimum resistance that can be obtained from them?
2. How many different resistance combinations are possible with three equal resistors taken all of them together?
3. Write symbols for the following:  
(a) Cell (b) Battery (c) Fixed resistance (d) Wires crossing without contact  
(e) Variable resistance (f) A wire joint
4. Write symbols for the following: (a) Ammeter (b) Voltmeter (c) Galvanometer  
(d) Open switch (e) Closed switch

5. Draw a labelled circuit diagram for the verification of Ohm's law. Plot a I-V graph for an ohmic conductor.
6. With the help of a diagram, derive the formula for the equivalent resistance of three resistances connected in series.
7. With the help of a diagram, derive the formula for the equivalent resistance of three resistances connected in parallel.
8. Write the SI and commercial unit of energy. Derive the relation between them.
9. What do you mean by resistivity of a conductor? What are the factors on which the resistance of a conductor depends?
10. State Joule's law of heating. Derive the formula for the Heat produced due to current flowing in a conductor.

**LONG ANSWER TYPE QUESTIONS (5 MARKS)**

1. Discuss series and parallel combinations of resistors with their salient features.
2. What is electric energy and electric power? Derive their expressions and define their units.
3. What is Ohm's law? How is it represented graphically? Derive an expression for the resultant resistance of series combinations of resistors.
4. State Ohm's law? Derive an expression for the equivalent resistance of parallel combinations of resistors.
5. What is Joule's heating effect? How can it be demonstrated experimentally? List its four applications in daily life.
6. What is electrical resistivity of a material? What is its unit? Describe an experimentally to study the factors on which the resistance of conducting wire depends?

**All Numerical based on series and parallel combinations of resistances come under this section. Please refer page no. 16 – 26.**



## CHAPTER – 13

### MAGNETIC EFFECT OF CURRENT

The term magnetic effect of electric current means that an electric current flowing in a wire produces a magnetic field around it.

A current flowing in a wire always gives rise to a magnetic field around it. The magnetic effect of current is also called electromagnetism which means electricity produces magnetism. In figure, the deflection of compass needle by the current carrying wire in the below experiment show that an electric current produces a magnetic field around it.

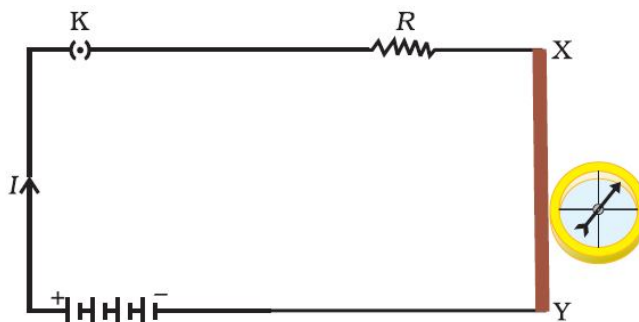

#### MAGNET

A magnet is an object, which attracts pieces of iron, steel, nickel and cobalt. It has two poles at ends – South and North Pole.

- Like magnetic poles repel each other.
- Unlike magnetic poles attract each other.

#### MAGNETIC FIELD

The space surrounding a magnet in which the force of attraction and repulsion is exerted is called a magnetic field.

#### MAGNETIC FIELD LINES

The magnetic field lines are the lines drawn in a magnetic field along which a north magnetic pole would move. These are also known as magnetic lines of forces.

#### PROPERTIES OF MAGNETIC FIELD LINES

1. A magnetic field lines originate from north pole and end at its south pole.
2. A magnetic field line is a closed and continuous curve.
3. The magnetic field lines are closer near the poles of a magnet where the magnetic field is strong and farther apart where the magnetic field is weak.
4. The magnetic field lines never intersect each other.
5. A uniform magnetic field is represented by parallel and equidistant field lines.

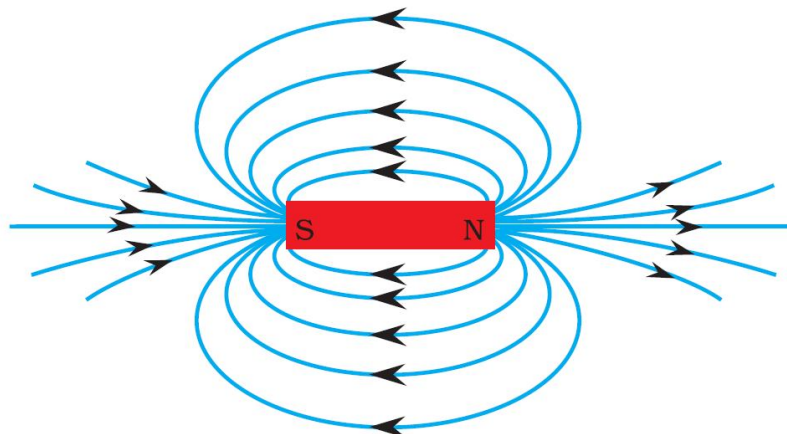

### INTEXT QUESTIONS PAGE NO. 224

1. Why does a compass needle get deflected when brought near a bar magnet?

**Ans.** A compass gets deflected due to the forces acting on its poles due to the magnetic field of the bar magnet.

### **MAGNETIC FIELD DUE TO A CURRENT THROUGH A STRAIGHT CONDUCTOR**

The magnetic field lines around a straight conductor carrying current are concentric circles whose centres lies on the wire.

The magnitude of magnetic field produced by a straight current carrying wire at a point-

- directly proportional to current passing in the wire.
- inversely proportional to the distance of that point from the wire.

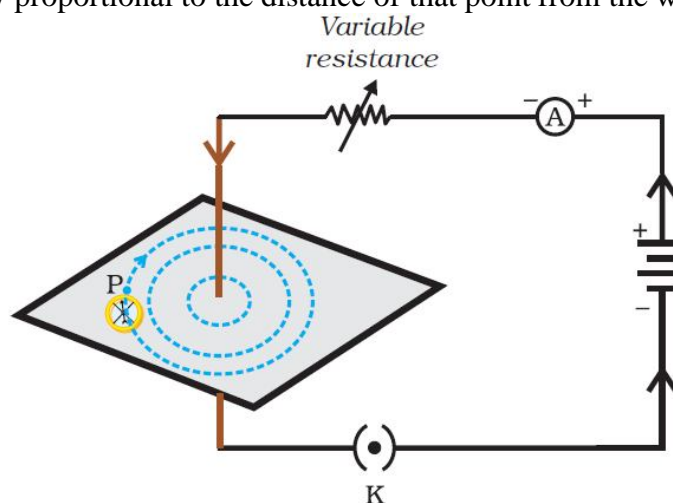

### **RIGHT-HAND THUMB RULE**

When a current-carrying straight conductor is holding in right hand such that the thumb points towards the direction of current. Then fingers will wrap around the conductor in the direction of the field lines of the magnetic field, as shown in below figure. This is known as the right-hand thumb rule

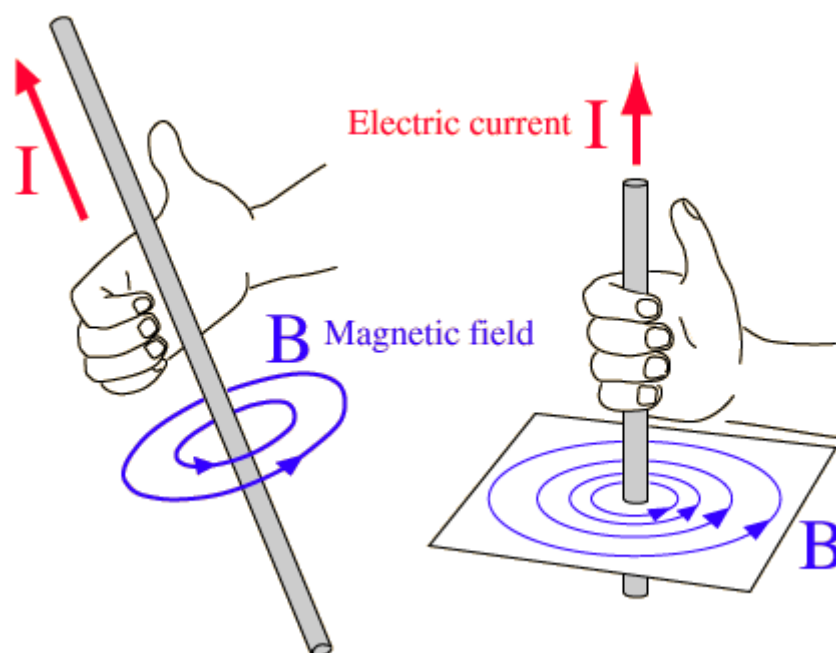

Thumb-points in the direction of current then direction of fingers encircle the wire give the direction of magnetic field around the wire.

### **INTEXT QUESTIONS PAGE NO. 228**

1. Draw magnetic field lines around a bar magnet.

**Ans.**

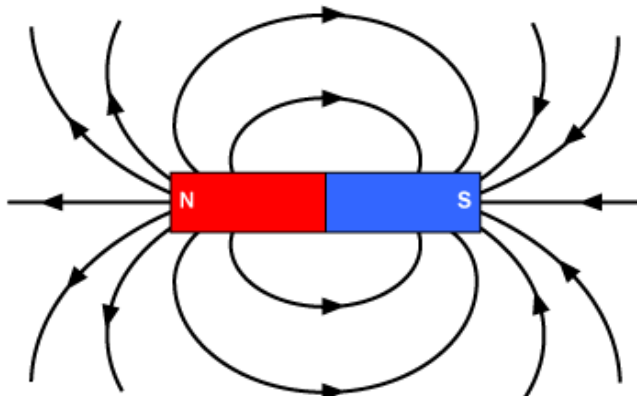

2. List the properties of magnetic lines of force.

**Ans.** Refer in page no. 1

3. Why don't two magnetic lines of force intersect each other?

**Ans.** If two magnetic lines of force intersect then there would be two directions of magnetic field at that point, which is absurd. That is why they never intersect.

### **MAGNETIC FIELD DUE TO A CURRENT THROUGH A CIRCULAR LOOP**

The magnetic field lines are circular near the current carrying loop. As we move away, the concentric circles become bigger and bigger. At the centre, the lines are straight.

At the centre, all the magnetic field lines are in the same direction due to which the strength of magnetic field increases.

The strength of magnetic field produced by a current carrying circular loop at its centre is

- directly proportional to the current passing
- inversely proportional to the radius of the circular loop

The strength of magnetic field produced by a circular coil carrying current is directly proportional to both number of turns ( $n$ ) and current ( $I$ ) but inversely proportional to its radius ( $r$ ).

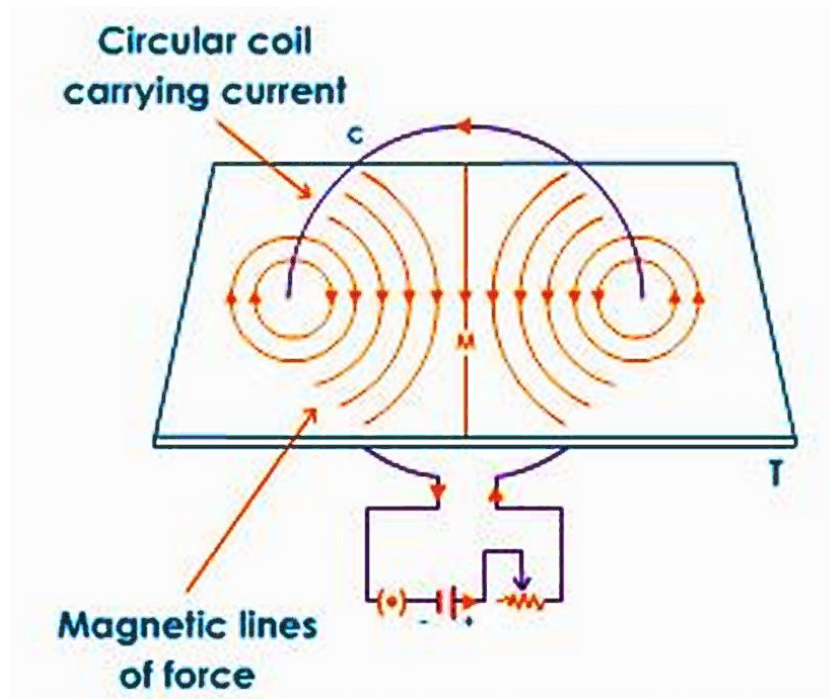

### MAGNETIC FIELD DUE TO A CURRENT IN A SOLENOID

The insulated copper wire wound on a cylindrical tube such that its length is greater than its diameter is called a solenoid. The solenoid is from greek word for channel.

- The solenoid is a long coil containing a large number of close turns of insulated copper wire.
- The magnetic field produced by a current carrying solenoid is similar to the magnetic field produced by a bar magnet.
- The current in each turn of a current carrying solenoid flows in the same direction due to which the magnetic field produced by each turn of the solenoid adds up, giving a strong magnetic field inside the solenoid.

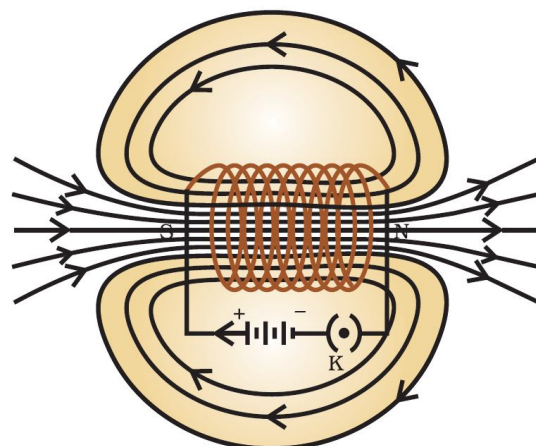

The strong magnetic field produced inside a current-carrying solenoid can be used to magnetise a piece of magnetic material like soft iron, when placed inside the solenoid. The magnet thus formed is called an electromagnet.

So, a solenoid is used for making electromagnets.

The strength of magnetic field produced by a carrying current solenoid depends on

- number of turns( $n$ )
- strength of current( $I$ )
- nature of core material used in solenoid – use of soft iron as core in a solenoid produces the strongest magnetism.

## ELECTROMAGNETS AND PERMANENT MAGNETS

An electromagnet is a temporary strong magnet and is just a solenoid with its winding on soft iron core.

A permanent magnet is made from steel. As steel has more retentivity than iron, it does not lose its magnetism easily.

### Difference between Electromagnet and permanent magnet

Electromagnet	Permanent magnet
1. An electromagnet is a temporary magnet as it can readily demagnetized by stopping the current through the solenoid.	1. A permanent magnet cannot be readily demagnetized.
2. Strength can be changed.	2. Strength cannot be changed.
3. It produces very strong magnetic forces.	3. It produces weak forces of attraction.
4. Polarity can be changed by changing the direction of the current.	4. Polarity is fixed and cannot be changed.

### Q. Why soft iron is used for making the core of an electromagnet?

Soft iron is used for making the core of an electromagnet because soft iron loses all of its magnetism when current in the coil is switched off.

### Q. Why steel is not used for making the core of an electromagnet?

Steel is not used for making the core of an electromagnet because steel does not lose all of its magnetism when current in the coil is switched off.

## INTEXT QUESTIONS PAGE NO. 229 and 230

1. Consider a circular loop of wire lying in the plane of the table. Let the current pass through the loop clockwise. Apply the right-hand rule to find out the direction of the magnetic field inside and outside the loop.

For downward direction of current flowing in the circular loop, the direction of magnetic field lines will be as if they are emerging from the table outside the loop and merging in the table inside the loop. Similarly, for upward direction of current flowing in the circular loop, the direction of magnetic field lines will be as if they are emerging from the table outside the loop and merging in the table inside the loop, as shown in the given figure.

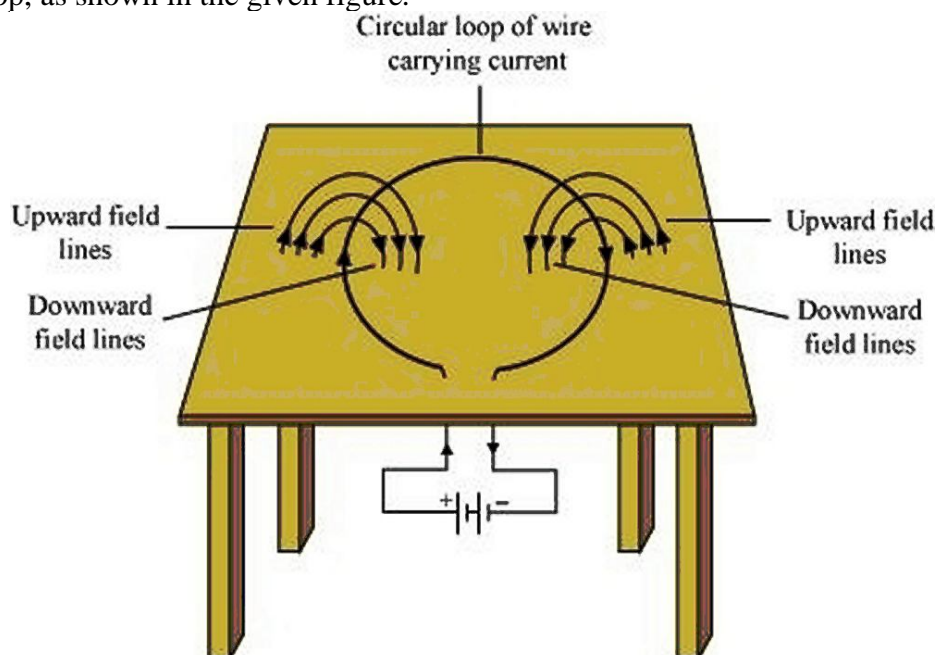

2. The magnetic field in a given region is uniform. Draw a diagram to represent it.

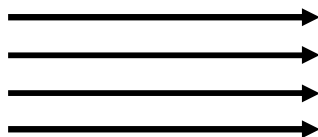

3. Choose the correct option: The magnetic field inside a long straight solenoid-carrying current (a) is zero. (b) decreases as we move towards its end. (c) increases as we move towards its end. (d) is the same at all points.  
The magnetic field for a point inside a long straight solenoid carrying current is double than for a point situated at one of its ends. Thus, the correct option is (b).

### FORCE ON A CURRENT-CARRYING CONDUCTOR IN A MAGNETIC FIELD

When a current carrying conductor is placed in a magnetic field it experiences a force, except when it is placed parallel to the magnetic field.

The force acting on a current carrying conductor in a magnetic field is due to interaction between:

1. Magnetic force due to current-carrying conductor and
2. External magnetic field in which the conductor is placed.

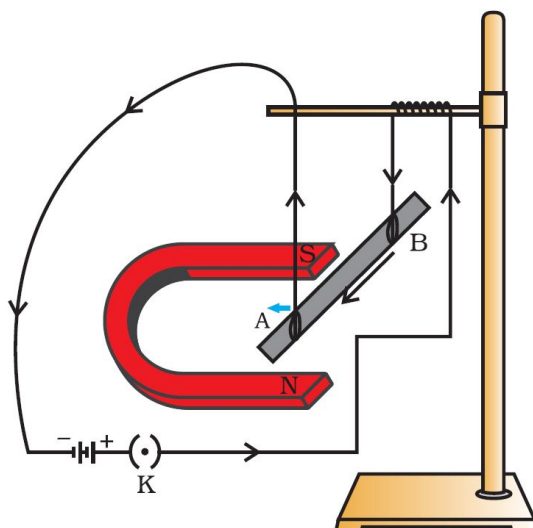

In the above figure, a current-carrying rod, AB, experiences a force perpendicular to its length and the magnetic field.

The displacement of the rod in the above activity suggests that a force is exerted on the current-carrying aluminium rod when it is placed in a magnetic field. It also suggests that the direction of force is also reversed when the direction of current through the conductor is reversed. Now change the direction of field to vertically downwards by interchanging the two poles of the magnet. It is once again observed that the direction of force acting on the current-carrying rod gets reversed. It shows that the direction of the force on the conductor depends upon the direction of current and the direction of the magnetic field. We considered the direction of the current and that of the magnetic field perpendicular to each other and found that the force is perpendicular to both of them.

### FLEMING'S LEFT HAND RULE

Fleming's left hand rule (for electric motors) shows the direction of the thrust on a conductor carrying a current in a magnetic field. The left hand is held with the thumb, index finger and middle finger mutually at right angles.

The First finger represents the direction of the magnetic Field. (north to south)

The Second finger represents the direction of the Current (the direction of the current is the direction of conventional current; from positive to negative).  
The Thumb represents the direction of the Thrust or resultant Motion.

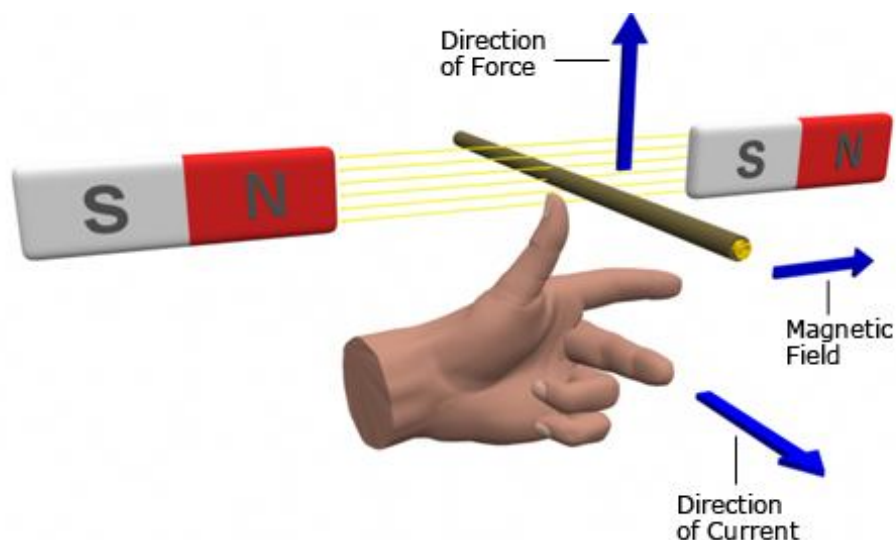

### **FLEMING'S RIGHT HAND RULE**

Fleming's right hand rule (for generators) shows the direction of induced current when a conductor moves in a magnetic field.

The right hand is held with the thumb, first finger and second finger mutually perpendicular to each other {at right angles}, as shown in the diagram .

The Thumb represents the direction of Motion of the conductor.  
The First finger represents the direction of the Field. (north to south)  
The Second finger represents the direction of the induced or generated Current (the direction of the induced current will be the direction of conventional current; from positive to negative).

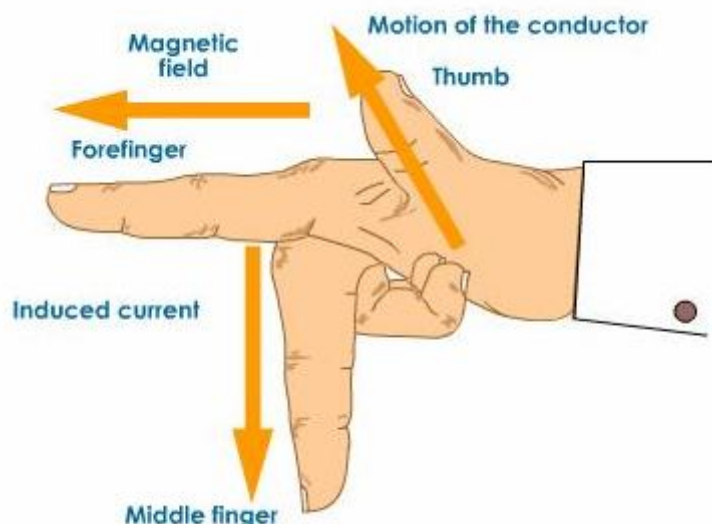

### **INTEXT QUESTIONS PAGE NO. 231 AND 232**

1. Which of the following property of a proton can change while it moves freely in a magnetic field? (There may be more than one correct answer.) (a) mass (b) speed (c) velocity (d) momentum

Whenever a charged proton moves in a magnetic field, its velocity changes and as a result of this its momentum change. Thus (c) and (d) are the properties which change when a proton moves freely in a magnetic field.

2. In Activity 13.7, how do we think the displacement of rod AB will be affected if (i) current in rod AB is increased; (ii) a stronger horse-shoe magnet is used; and (iii) length of the rod AB is increased?

- (i) If the current in the rod AB is increased, force also increases.  
 (ii) When a stronger horse-shoe magnet is used, magnetic field increases as a result force also increases.  
 (iii) If the length of the rod AB is increased, force also increased.

3. A positively-charged particle (alpha-particle) projected towards west is deflected towards north by a magnetic field. The direction of magnetic field is (a) towards south (b) towards east (c) downward (d) upward

The direction of the motion of proton is the direction of current. The direction of force on the proton is towards north. Applying Fleming's left hand rule, the direction of magnetic field is upward. The correct option is (d).

### ELECTRIC MOTOR

An electric motor is a rotating device that converts electrical energy to mechanical energy. Electric motor is used as an important component in electric fans, refrigerators, mixers, washing machines, computers, MP3 players etc.

**Principle:** When a coil carrying current is placed in a magnetic field, it experiences a torque. As a result of this torque, the coil begins to rotate.

#### Construction:

It consists of a rectangular coil ABCD of insulated copper wire. The coil is placed between the two poles of a magnetic field such that the arm AB and CD are perpendicular to the direction of the magnetic field. The ends of the coil are connected to the two halves P and Q of a split ring. The inner sides of these halves are insulated and attached to an axle. The external conducting edges of P and Q touch two conducting stationary brushes X and Y, respectively, as shown in the below figure

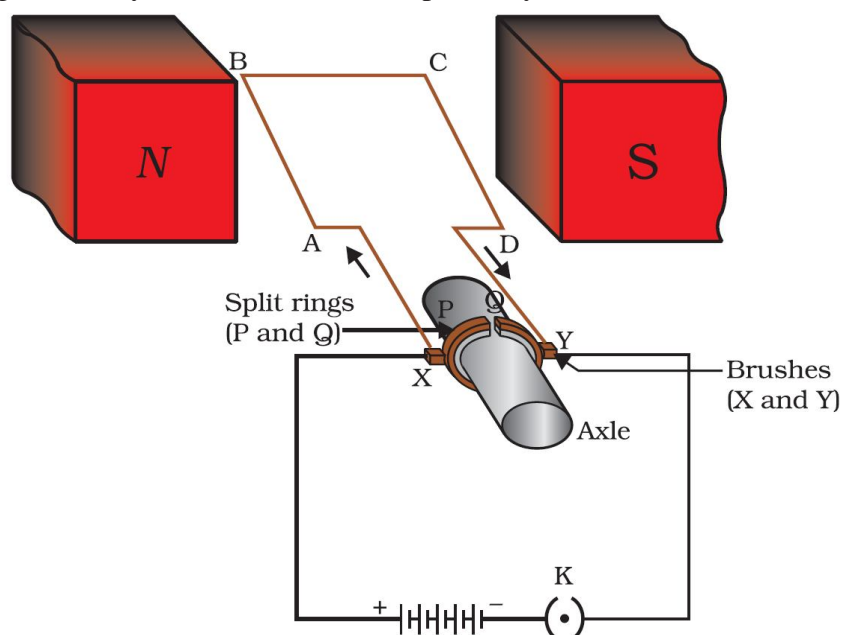

#### Working:

Current in the coil ABCD enters from the source battery through conducting brush X and flows back to the battery through brush Y.



Notice that the current in arm AB of the coil flows from A to B. In arm CD it flows from C to D, that is, opposite to the direction of current through arm AB.

On applying Fleming's left hand rule for the direction of force on a current-carrying conductor in a magnetic field.. We find that the force acting on arm AB pushes it downwards while the force acting on arm CD pushes it upwards. Thus the coil and the axle O, mounted free to turn about an axis, rotate anti-clockwise.

At half rotation, Q makes contact with the brush X and P with brush Y. Therefore the current in the coil gets reversed and flows along the path DCBA. A device that reverses the direction of flow of current through a circuit is called a commutator. In electric motors, the split ring acts as a commutator.

The reversal of current also reverses the direction of force acting on the two arms AB and CD. Thus the arm AB of the coil that was earlier pushed down is now pushed up and the arm CD previously pushed up is now pushed down. Therefore the coil and the axle rotate half a turn more in the same direction. The reversing of the current is repeated at each half rotation, giving rise to a continuous rotation of the coil and to the axle.

### Uses of electric motor:

The commercial motors use (i) an electromagnet in place of permanent magnet; (ii) large number of turns of the conducting wire in the current-carrying coil; and (iii) a soft iron core on which the coil is wound. The soft iron core, on which the coil is wound, plus the coils, is called an armature. This enhances the power of the motor.

### INTEXT QUESTIONS PAGE NO. 231 AND 232

1. State Fleming's left-hand rule.

**Ans.** Fleming's left hand rule states that if we arrange the thumb, the centre finger, and the forefinger of the left hand at right angles to each other, then the thumb points towards the direction of the magnetic force, the centre finger gives the direction of current, and the forefinger points in the direction of magnetic field.

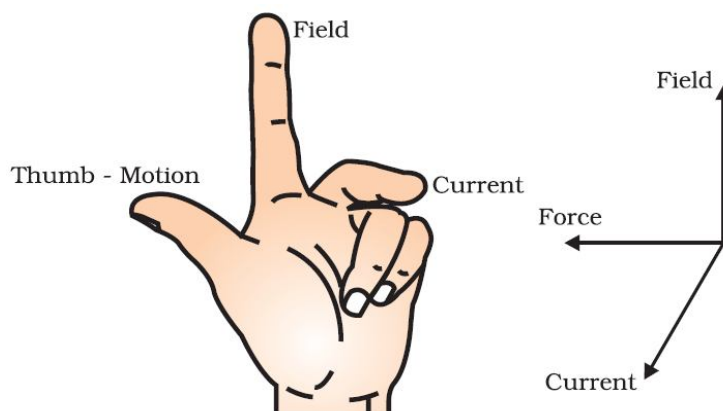

2. What is the principle of an electric motor?

**Ans.** The working principle of an electric motor is based on the magnetic effect of current. A current-carrying loop experiences a force and rotates when placed in a magnetic field. The direction of rotation of the loop is given by the Fleming's left-hand rule.

3. What is the role of the split ring in an electric motor?

**Ans.** The split ring in the electric motor acts as a commutator. The commutator reverses the direction of current flowing through the coil after each half rotation of

the coil. Due to this reversal of the current, the coil continues to rotate in the same direction.

## ELECTROMAGNETIC INDUCTION

The production of electricity from magnetism is called Electromagnetic induction. When a straight wire is moved up and down rapidly between the poles of magnet, then an electric current is produced in the wire. This is an example of electromagnetic induction

The process of electromagnetic induction has led to the construction of generators for producing electricity at power stations

The current produced by moving a straight wire in a magnetic field is called an induced current. In the below figure, moving a magnet towards a coil sets up a current in the coil circuit, as indicated by deflection in the galvanometer needle.

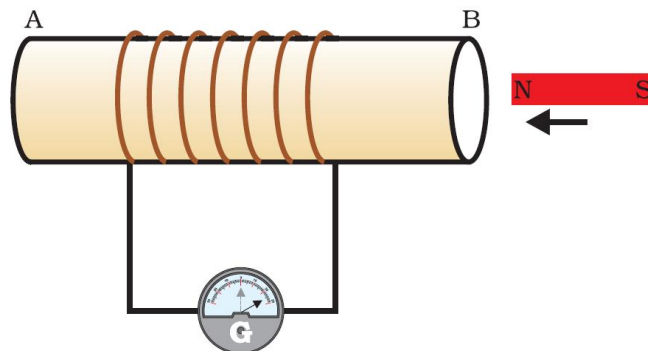

If the bar magnet moved towards south pole of the magnet towards the end B of the coil, the deflections in the galvanometer would just be opposite to the previous case. When the coil and the magnet are both stationary, there is no deflection in the galvanometer. It is, thus, clear from this activity that motion of a magnet with respect to the coil produces an induced potential difference, which sets up an induced electric current in the circuit.

## ELECTRIC GENERATOR

In an electric generator, mechanical energy is used to rotate a conductor in a magnetic field to produce electricity.

**Principle:** Whenever in a closed circuit, the magnetic field lines change, an induced current is produced.

### Construction:

- An electric generator, as shown in the below figure, consists of a rotating rectangular coil ABCD placed between the two poles of a permanent magnet.
- The two ends of this coil are connected to the two rings R1 and R2.
- The inner side of these rings are made insulated.
- The two conducting stationary brushes B1 and B2 are kept pressed separately on the rings R1 and R2, respectively.
- The two rings R1 and R2 are internally attached to an axle.
- The axle may be mechanically rotated from outside to rotate the coil inside the magnetic field.
- Outer ends of the two brushes are connected to the galvanometer to show the flow of current in the given external circuit.

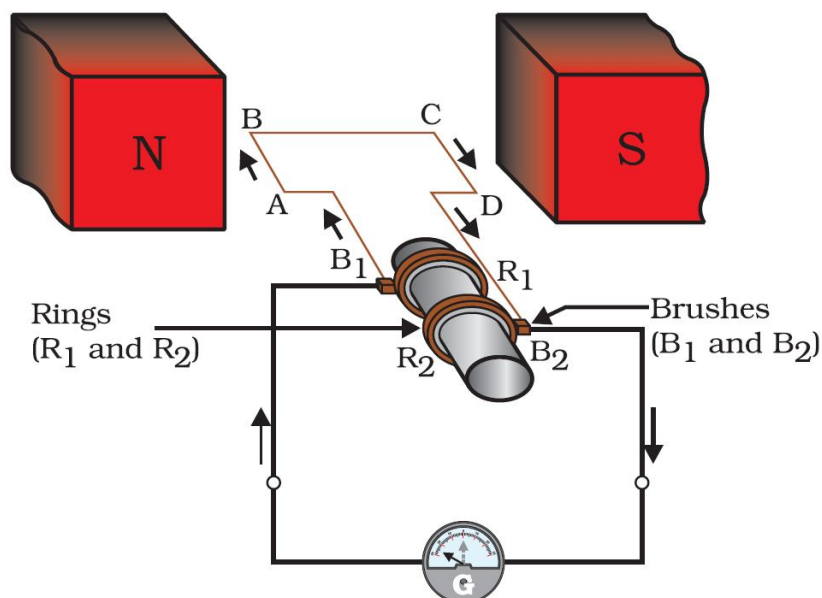

**Working:**

When the axle attached to the two rings is rotated such that the arm AB moves up (and the arm CD moves down) in the magnetic field produced by the permanent magnet. Let us say the coil ABCD is rotated clockwise in the arrangement shown in the above figure.

By applying Fleming’s right-hand rule, the induced currents are set up in these arms along the directions AB and CD. Thus an induced current flows in the direction ABCD. If there are larger numbers of turns in the coil, the current generated in each turn adds up to give a large current through the coil. This means that the current in the external circuit flows from B2 to B1.

After half a rotation, arm CD starts moving up and AB moving down. As a result, the directions of the induced currents in both the arms change, giving rise to the net induced current in the direction DCBA. The current in the external circuit now flows from B1 to B2. Thus after every half rotation the polarity of the current in the respective arms changes. Such a current, which changes direction after equal intervals of time, is called an alternating current (abbreviated as AC). This device is called an AC generator.

To get a direct current (DC, which does not change its direction with time), a split-ring type commutator must be used. With this arrangement, one brush is at all times in contact with the arm moving up in the field, while the other is in contact with the arm moving down. We have seen the working of a split ring commutator in the case of an electric motor Thus a unidirectional current is produced. The generator is thus called a DC generator. The difference between the direct and alternating currents is that the direct current always flows in one direction, whereas the alternating current reverses its direction periodically.

**INTEXT QUESTIONS PAGE NO. 236**

1. Explain different ways to induce current in a coil.

The different ways to induce current in a coil are as follows:

- (a) If a coil is moved rapidly between the two poles of a horse-shoe magnet, then an electric current is induced in the coil.
- (b) If a magnet is moved relative to a coil, then an electric current is induced in the coil

### **INTEXT QUESTIONS PAGE NO. 237**

1. State the principle of an electric generator.  
An electric generator works on the principle of electromagnetic induction. It generates electricity by rotating a coil in a magnetic field.
2. Name some sources of direct current.  
Some sources of direct current are cell, DC generator, etc
3. Which sources produce alternating current?  
AC generators, power plants, etc., produce alternating current
4. Choose the correct option: A rectangular coil of copper wires is rotated in a magnetic field. The direction of the induced current changes once in each (a) two revolutions (b) one revolution (c) half revolution (d) one-fourth revolution  
(c) When a rectangular coil of copper is rotated in a magnetic field, the direction of the induced current in the coil changes once in each half revolution. As a result, the direction of current in the coil remains the same

### **DOMESTIC ELECTRIC CIRCUITS**

#### When does an electric short circuit occur?

If the resistance of an electric circuit becomes very low, then the current flowing through the circuit becomes very high. This is caused by connecting too many appliances to a single socket or connecting high power rating appliances to the light circuits. This results in a short circuit.

When the insulation of live and neutral wires undergoes wear and tear and then touches each other, the current flowing in the circuit increases abruptly. Hence, a short circuit occurs.

#### What is the function of an earth wire? Why is it necessary to earth metallic appliances?

The metallic body of electric appliances is connected to the earth by means of earth wire so that any leakage of electric current is transferred to the ground. This prevents any electric shock to the user. That is why earthing of the electrical appliances is necessary.

#### What is Electric fuse? What is the important of electric fuse?

Electric Fuse consists of a piece of wire made of a metal or an alloy of appropriate melting point, for example aluminium, copper, iron, lead etc. If a current larger than the specified value flows through the circuit, the temperature of the fuse wire increases. This melts the fuse wire and breaks the circuit. Fuse is the most important safety device, used for protecting the circuits due to short-circuiting or overloading of the circuits. The use of an electric fuse prevents the electric circuit and the appliance from a possible damage by stopping the flow of unduly high electric current. The fuses used for domestic purposes are rated as 1 A, 2 A, 3 A, 5 A, 10 A, etc.

### **INTEXT QUESTIONS PAGE NO. 238**

1. Name two safety measures commonly used in electric circuits and appliances.  
Two safety measures commonly used in electric circuits and appliances are as follows:  
(i) Each circuit must be connected with an electric fuse. This prevents the flow of excessive current through the circuit. When the current passing through the wire exceeds the maximum limit of the fuse element, the fuse melts to stop the flow of current through that circuit, hence protecting the appliances connected to the circuit.

- (ii) Earthing is a must to prevent electric shocks. Any leakage of current in an electric appliance is transferred to the ground and people using the appliance do not get the shock.
2. An electric oven of 2 kW power rating is operated in a domestic electric circuit (220 V) that has a current rating of 5 A. What result do you expect? Explain. Current drawn by the electric oven can be obtained by the expression,
- $$P=VI$$
- $$I = \frac{P}{V}$$
- Where, current = I. Power of the oven, P = 2 kW = 2000W  
Voltage supplied, V = 220V
- $$I = \frac{2000}{220} = 9.09A$$
- Hence, the current drawn by the electric oven is 9.09 A, which exceeds the safe limit of the circuit. Fuse element of the electric fuse will melt and break the circuit.
3. What precaution should be taken to avoid the overloading of domestic electric circuits?
- The precautions that should be taken to avoid the overloading of domestic circuits are as follows:
- Too many appliances should not be connected to a single socket.
  - Too many appliances should not be used at the same time.
  - Faulty appliances should not be connected in the circuit
  - Fuse should be connected in the circuit.

## **MAGNETISM IN MEDICINE**

An electric current always produces a magnetic field. Even weak ion currents that travel along the nerve cells in our body produce magnetic fields. When we touch something, our nerves carry an electric impulse to the muscles we need to use. This impulse produces a temporary magnetic field. These fields are very weak and are about one-billionth of the earth's magnetic field. Two main organs in the human body where the magnetic field produced is significant, are the heart and the brain. The magnetic field inside the body forms the basis of obtaining the images of different body parts. This is done using a technique called **Magnetic Resonance Imaging (MRI)**. Analysis of these images helps in medical diagnosis. Magnetism has, thus, got important uses in medicine.

## **EXERCISE QUESTIONS PAGE NO. 240**

1. Which of the following correctly describes the magnetic field near a long straight wire?
- The field consists of straight lines perpendicular to the wire
  - The field consists of straight lines parallel to the wire
  - The field consists of radial lines originating from the wire
  - The field consists of concentric circles centred on the wire
- Ans.** (d) The magnetic field lines, produced around a straight current-carrying conductor, are concentric circles. Their centres lie on the wire.
2. The phenomenon of electromagnetic induction is  
(a) the process of charging a body

(b) the process of generating magnetic field due to a current passing through a coil  
(c) producing induced current in a coil due to relative motion between a magnet and the coil

(d) the process of rotating a coil of an electric motor

**Ans.** (c) When a straight coil and a magnet are moved relative to each other, a current is induced in the coil. This phenomenon is known as electromagnetic induction.

3. The device used for producing electric current is called a

(a) generator. (b) galvanometer. (c) ammeter. (d) motor.

**Ans.** (a) An electric generator produces electric current. It converts mechanical energy into electricity.

4. The essential difference between an AC generator and a DC generator is that

(a) AC generator has an electromagnet while a DC generator has permanent magnet.

(b) DC generator will generate a higher voltage.

(c) AC generator will generate a higher voltage.

(d) AC generator has slip rings while the DC generator has a commutator.

**Ans.** (d) An AC generator has two rings called slip rings. A DC generator has two half rings called commutator. This is the main difference between both the types of generators.

5. At the time of short circuit, the current in the circuit

(a) reduces substantially. (b) does not change.

(c) increases heavily. (d) vary continuously.

**Ans.** (c) When two naked wires of an electric circuit touch each other, the amount of current that is flowing in the circuit increases abruptly. This causes short-circuit.

6. State whether the following statements are true or false.

(a) An electric motor converts mechanical energy into electrical energy.

(b) An electric generator works on the principle of electromagnetic induction.

(c) The field at the centre of a long circular coil carrying current will be parallel straight lines.

(d) A wire with a green insulation is usually the live wire of an electric supply.

**Ans.** (a) False

An electric motor converts electrical energy into mechanical energy.

(b) True

A generator is an electric device that generates electricity by rotating a coil in a magnetic field. It works on the principle of electromagnetic induction.

(c) True

A long circular coil is a long solenoid. The magnetic field lines inside the solenoid are parallel lines.

(d) False

Live wire has red insulation cover, whereas earth wire has green insulation colour in the domestic circuits.

7. List three sources of magnetic fields.

**Ans.** Three sources of magnetic fields are as follows:

(a) Current-carrying conductors

(b) Permanent magnets

(c) Electromagnets

8. How does a solenoid behave like a magnet? Can you determine the north and south poles of a current-carrying solenoid with the help of a bar magnet? Explain.

**Ans.** A solenoid is a long coil of circular loops of insulated copper wire. Magnetic field lines are produced around the solenoid when a current is allowed to flow through it. The magnetic field produced by it is similar to the magnetic field of a bar magnet. The field lines produced in a current-carrying solenoid is shown in the following figure.

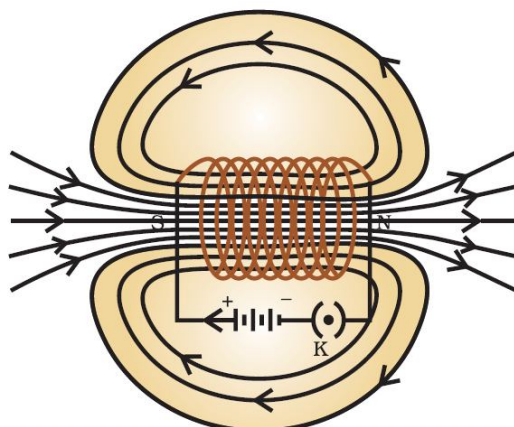

In the above figure, when the north pole of a bar magnet is brought near the end connected to the negative terminal of the battery, the solenoid repels the bar magnet. Since like poles repel each other, the end connected to the negative terminal of the battery behaves as the north pole of the solenoid and the other end behaves as a south pole. Hence, one end of the solenoid behaves as a north pole and the other end behaves as a south pole.

9. When is the force experienced by a current-carrying conductor placed in a magnetic field largest?

**Ans.** The force experienced by a current-carrying conductor is the maximum when the direction of current is perpendicular to the direction of the magnetic field.

10. Imagine that you are sitting in a chamber with your back to one wall. An electron beam, moving horizontally from back wall towards the front wall, is deflected by a strong magnetic field to your right side. What is the direction of magnetic field?

**Ans.** The direction of magnetic field is given by Fleming's left hand rule. Magnetic field inside the chamber will be perpendicular to the direction of current (opposite to the direction of electron) and direction of deflection/force i.e., either upward or downward. The direction of current is from the front wall to the back wall because negatively charged electrons are moving from back wall to the front wall. The direction of magnetic force is rightward. Hence, using Fleming's left hand rule, it can be concluded that the direction of magnetic field inside the chamber is downward.

11. Draw a labelled diagram of an electric motor. Explain its principle and working. What is the function of a split ring in an electric motor?

**Ans.** An electric motor is a rotating device that converts electrical energy to mechanical energy. Electric motor is used as an important component in electric fans, refrigerators, mixers, washing machines, computers, MP3 players etc.

**Principle:** When a coil carrying current is placed in a magnetic field, it experiences a torque. As a result of this torque, the coil begins to rotate.

**Construction:**

It consists of a rectangular coil ABCD of insulated copper wire. The coil is placed between the two poles of a magnetic field such that the arm AB and CD are perpendicular to the direction of the magnetic field. The ends of the coil are connected to the two halves P and Q of a split ring. The inner sides of these halves are insulated and attached to an axle. The external conducting edges of P and Q touch two conducting stationary brushes X and Y, respectively, as shown in the below figure

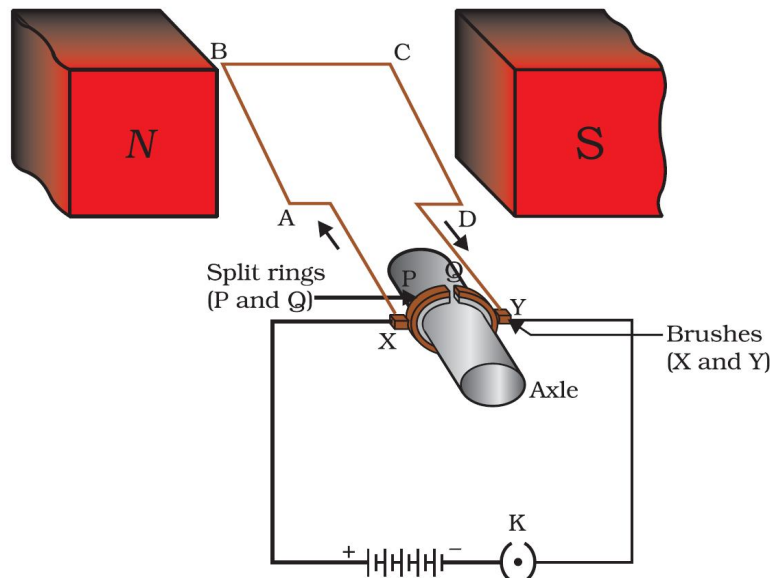
**Working:**

Current in the coil ABCD enters from the source battery through conducting brush X and flows back to the battery through brush Y.

Notice that the current in arm AB of the coil flows from A to B. In arm CD it flows from C to D, that is, opposite to the direction of current through arm AB.

On applying Fleming's left hand rule for the direction of force on a current-carrying conductor in a magnetic field.. We find that the force acting on arm AB pushes it downwards while the force acting on arm CD pushes it upwards. Thus the coil and the axle O, mounted free to turn about an axis, rotate anti-clockwise.

At half rotation, Q makes contact with the brush X and P with brush Y. Therefore the current in the coil gets reversed and flows along the path DCBA. A device that reverses the direction of flow of current through a circuit is called a commutator. In electric motors, the split ring acts as a commutator.

The reversal of current also reverses the direction of force acting on the two arms AB and CD. Thus the arm AB of the coil that was earlier pushed down is now pushed up and the arm CD previously pushed up is now pushed down. Therefore the coil and the axle rotate half a turn more in the same direction. The reversing of the current is repeated at each half rotation, giving rise to a continuous rotation of the coil and to the axle.

12. Name some devices in which electric motors are used.

**Ans.** Some devices in which electric motors are used are as follows:

(a) Water pumps (b) Electric fans (c) Electric mixers (d) Washing machines

13. A coil of insulated copper wire is connected to a galvanometer. What will happen if a bar magnet is (i) pushed into the coil, (ii) withdrawn from inside the coil, (iii) held stationary inside the coil?



**Ans.** A current induces in a solenoid if a bar magnet is moved relative to it. This is the principle of electromagnetic induction.

(i) When a bar magnet is pushed into a coil of insulated copper wire, a current is induced momentarily in the coil. As a result, the needle of the galvanometer deflects momentarily in a particular direction.

(ii) When the bar magnet is withdrawn from inside the coil of the insulated copper wire, a current is again induced momentarily in the coil in the opposite direction. As a result, the needle of the galvanometer deflects momentarily in the opposite direction.

(iii) When a bar magnet is held stationary inside the coil, no current will be induced in the coil. Hence, galvanometer will show no deflection.

14. Two circular coils A and B are placed closed to each other. If the current in the coil A is changed, will some current be induced in the coil B? Give reason.

**Ans.** Two circular coils A and B are placed closed to each other. When the current in coil A is changed, the magnetic field associated with it also changes. As a result, the magnetic field around coil B also changes. This change in magnetic field lines around coil B induces an electric current in it. This is called electromagnetic induction.

15. State the rule to determine the direction of a (i) magnetic field produced around a straight conductor-carrying current, (ii) force experienced by a current-carrying straight conductor placed in a magnetic field which is perpendicular to it, and (iii) current induced in a coil due to its rotation in a magnetic field.

**Ans.** (i) Maxwell's right hand thumb rule

(ii) Fleming's left hand rule

(iii) Fleming's right hand rule

16. Explain the underlying principle and working of an electric generator by drawing a labelled diagram. What is the function of brushes?

**Ans.** In an electric generator, mechanical energy is used to rotate a conductor in a magnetic field to produce electricity.

**Principle:** Whenever in a closed circuit, the magnetic field lines change, an induced current is produced.

**Construction:**

- An electric generator, as shown in the below figure, consists of a rotating rectangular coil ABCD placed between the two poles of a permanent magnet.
- The two ends of this coil are connected to the two rings R1 and R2.
- The inner side of these rings are made insulated.
- The two conducting stationary brushes B1 and B2 are kept pressed separately on the rings R1 and R2, respectively.
- The two rings R1 and R2 are internally attached to an axle.
- The axle may be mechanically rotated from outside to rotate the coil inside the magnetic field.
- Outer ends of the two brushes are connected to the galvanometer to show the flow of current in the given external circuit.

**Working:**

When the axle attached to the two rings is rotated such that the arm AB moves up (and the arm CD moves down) in the magnetic field produced by the permanent magnet. Let us say the coil ABCD is rotated clockwise in the arrangement shown in the above figure.

By applying Fleming's right-hand rule, the induced currents are set up in these arms along the directions AB and CD. Thus an induced current flows in the direction ABCD. If there are larger numbers of turns in the coil, the current

generated in each turn adds up to give a large current through the coil. This means that the current in the external circuit flows from B2 to B1.

After half a rotation, arm CD starts moving up and AB moving down. As a result, the directions of the induced currents in both the arms change, giving rise to the net induced current in the direction DCBA. The current in the external circuit now flows from B1 to B2. Thus after every half rotation the polarity of the current in the respective arms changes. Such a current, which changes direction after equal intervals of time, is called an alternating current (abbreviated as AC). This device is called an AC generator.

To get a direct current (DC, which does not change its direction with time), a split-ring type commutator must be used. With this arrangement, one brush is at all times in contact with the arm moving up in the field, while the other is in contact with the arm moving down. We have seen the working of a split ring commutator in the case of an electric motor. Thus a unidirectional current is produced. The generator is thus called a DC generator. The difference between the direct and alternating currents is that the direct current always flows in one direction, whereas the alternating current reverses its direction periodically.

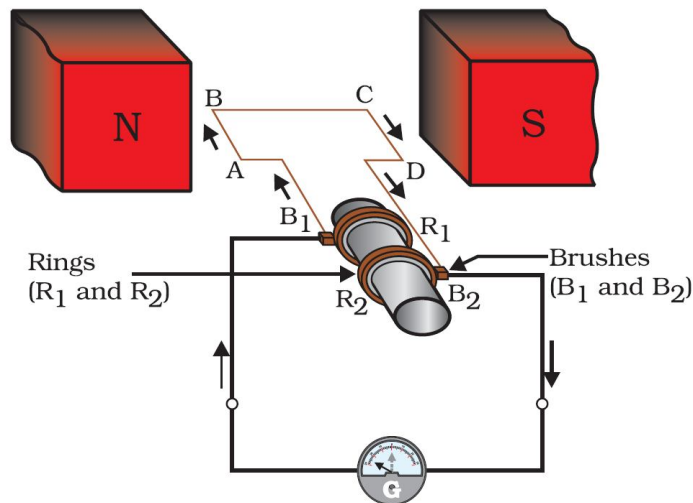

17. When does an electric short circuit occur?

**Ans.** If the resistance of an electric circuit becomes very low, then the current flowing through the circuit becomes very high. This is caused by connecting too many appliances to a single socket or connecting high power rating appliances to the light circuits. This results in a short circuit.

When the insulation of live and neutral wires undergoes wear and tear and then touches each other, the current flowing in the circuit increases abruptly. Hence, a short circuit occurs.

18. What is the function of an earth wire? Why is it necessary to earth metallic appliances?

**Ans.** The metallic body of electric appliances is connected to the earth by means of earth wire so that any leakage of electric current is transferred to the ground. This prevents any electric shock to the user. That is why earthing of the electrical appliances is necessary.

# ASSIGNMENT QUESTIONS FOR PRACTICE MAGNETIC EFFECTS OF ELECTRIC CURRENT

## VERY SHORT ANSWER TYPE QUESTIONS (1 MARK)

1. Name the scientist who discovered the magnetic effect of current.
2. Does a current flowing in a wire always give rise to a magnetic field around it?
3. State any two properties of magnetic field lines.
4. Why does a compass needle get deflected when brought near a bar magnet?
5. Name the effect of current on which an electromagnetic works.
6. What name is given to the combination of a solenoid and a soft iron core?
7. Can steel be used for making electromagnets?
8. Name the scientist who discovered that a current carrying conductor when placed in a magnetic field experiences a mechanical force.
9. When is the maximum force exerted on a current carrying conductor while it is kept in a magnetic field?
10. Does a current carrying conductor experience some force when kept parallel to the magnetic field?
11. Which rule is employed to find the direction of force on a current carrying conductor when kept in a magnetic field? State the rule and explain it by a diagram.
12. Name the transformation of energy involved in the electric motor.
13. What is the function of commutator rings in the electric motor?
14. What is the function of carbon brushes in the electric motor?
15. Name one application of electromagnetic induction.
16. What is the other name of electric generator?
17. Name the transformation of energy in an electric generator.

18. What is a turbine used for?
19. Name the different types of electric power plants for generating electricity on large scale.
20. Name the fuel used in a thermal power plant.
21. Name the fuel used in an atomic power plant.
22. What do you understand by magnetic field?
23. What do you mean by electromagnetism?
24. What is meant by magnetic effect of current?
25. Can you observe the magnetic field?
26. What do you mean by a magnetic line of force?
27. Is a magnetic line of force always a straight line?
28. What do you conclude from Oersted's experiment?
29. Can you magnetic line of force ever intersect each other?
30. What kind of magnetic field is produced by a straight current carrying conductor?
31. What kind of magnetic field is produced by a current carrying circular field?
32. What do you mean by a solenoid?
33. State the clock rule for a current carrying solenoid.
34. How does a current carrying solenoid behave?
35. What is the nature of magnetic field produced by a current carrying solenoid?
36. What is the magnitude and direction of the magnetic field inside a current carrying solenoid?
37. Name the effect of current upon which electromagnets are based?
38. Are electromagnets permanent magnets?
39. Name the material used for making the core of an electromagnet.

40. Can we use steel, instead of soft iron, for making the core of an electromagnet?  
Why?
41. Can we change the polarity of a permanent magnet?
42. Can we change the polarity of an electromagnet?
43. Is the strength of an electromagnet always constant?
44. Name the rule applied to know direction of the force acting on a current carrying conductor when placed in a magnetic field.
45. Name the transformations of energies takes place in an electric motor.
46. Name the two kinds of motors.
47. Which kind of motor is used in a fan?
48. Which kind of motor used in a battery-operated toy?
49. Name the experiment which formed the basis of an electric motor.
50. What forms the commutator of an electric motor?
51. State quantitatively, the effect of inserting an iron core into a current carrying solenoid.
52. Name the types of electromagnets commonly used.
53. What happens to the strength of an electromagnet when the magnitude of current decreases?
54. What will you prefer, soft iron or steel to make an electromagnet?
55. Can we produce electricity from magnetism?
56. Name the phenomenon in which an electric current could be produced in a circuit by changing the magnetic field.
57. What do you mean by electromagnetic induction?
58. What is e.m.i. or E.M.I.?
59. What do you understand by electric motor effect?
60. What is the cause of electromagnetic induction?

61. Does the AC generator have any slip ring?
62. Does the DC generator have two slip rings?
63. What is the frequency DC?
64. Name the fuel used by nuclear power station.
65. Name the device which converts electrical energy into kinetic energy.
66. What is the SI unit of induced emf?
67. State two factors on which the strength of induced current depends.
68. What is the SI unit of induced current?
69. What is electromagnetic induction?
70. What do you mean by a solenoid?

**SHORT ANSWER TYPE – I QUESTIONS (2 MARKS)**

1. Draw a labeled diagram of an electric motor.
2. State and explain Fleming's right hand rule for the direction of induced current.
3. What do you mean by DC? Show by a diagram.
4. What do you mean by AC? Show by a diagram.
5. Draw a labeled to show the magnetic field pattern due to a straight wire carrying current.
6. With the help of a diagram, indicate the direction of magnetic field produced by a current carrying conductor. Name the rule employed and state it.
7. With the help of a diagram, indicate the direction of magnetic field produced due to a circular wire carrying current.
8. Indicate the direction of the magnetic field produced in a solenoid when some current is passed through it.
9. How can we increase the strength of magnetic field produced by a circular coil carrying conductor?

10. What are the factors on which the strength of magnetic field produced by a current carrying solenoid depends?
11. List the factors affecting the strength of an electromagnet.
12. Show that magnetic lines of force due to a bar magnet.

**SHORT ANSWER TYPE – II QUESTIONS (3 MARKS)**

1. Briefly describe Oersted's experiment to demonstrate the magnetic effect of current.
2. What are magnetic field lines? Give their important properties.
3. How will you experimentally show the magnetic field produced by a straight current carrying conductor? Also state Maxwell's right hand grip rule.
4. What kind of magnetic field is produced by a current carrying circular coil? Show it with the help of a labeled diagram.
5. What do you mean by a solenoid? With the help of a labeled, show the magnetic field due to a current carrying solenoid.
6. What do you mean by an electromagnet? With the help of diagram show the two types of electromagnets. Give two uses of electromagnets.
7. How does AC differ from DC? What are the advantages and disadvantages of AC over DC?
8. What is the basic difference between an AC generator and a DC generator?
9. Briefly explain the phenomenon of earthing using examples.
10. Describe the salient features of tree system of wiring.

**LONG ANSWER TYPE QUESTIONS (5 MARKS)**

1. Why does a magnetic compass needle pointing North and South in the absence of a nearby magnet get deflected when a bar magnet or a current carrying loop is brought near it. Describe some salient features of magnetic lines of field concept.

2. With the help of a labeled circuit diagram, illustrate the pattern of field lines of the magnetic field around a current carrying straight long conducting wire. How is the right hand thumb rule useful to find the direction of magnetic field associated with a current carrying conductor?
3. Explain with the help of a labeled diagram the distribution of magnetic field due to a current through a circular loop. Why is it that if a current carrying coil has 'n' turn, the field produced at any point is a times as large as that produced by a single turn?
4. (a) State the factors on which the strength of an electromagnet depends. (b) How does an electromagnet differ from a bar magnet or permanent magnet?
5. How will you experimentally show that a current carrying conductor experiences a force when kept in a magnetic field?
6. What is the principle of an electric motor? Briefly explain the construction and working of an electric motor using a labeled diagram. State the factors on which the strength of a motor depends.
7. What is meant by electromagnetic inductions? How will you demonstrate this phenomenon with the help of an experiment? State the factors on which the strength the induced current depends.
8. Briefly describe the principle, construction and working of an AC generator or dynamo.
9. (a) How are electrical installations carried out in a house? (b) What is the main function of electric fuse? Briefly explain it.
10. What safety measures do you employ in the use of electricity?





## CHAPTER – 15

### OUR ENVIRONMENT

**Environment:** Our surrounding is called environment.

Living organisms live in different surroundings. Some plants and animals completely live in water and some others live on land.

Man also leads life in different surroundings. Some live in cities, some in towns and some in villages.

Plants, animals, human beings survive with the interaction between them and the non-living things like air, water and land.

Human beings depend on the resources of nature. These resources include soil, water, coal, electricity, oil, gas, etc. These resources improve the life style of human beings.

Environmental science can be defined as the study of organisms in relation to their surrounding.

Human activities related to livelihood and welfare generate waste. All wastes are pollutants and they create pollution in one way or another. Air, land and water surroundings are affected due to improper disposal of wastes which create an imbalance in the environment.

**Pollution:** Any undesirable change in the physical, chemical or biological characteristics of air, land and water that affect human life adversely is called pollution.

**Pollutant:** A substance released into the environment due to natural or human activity which affects adversely the environment is called pollutant. e.g. Sulphur-di-oxide, carbon-monoxide, lead, mercury, etc.

#### **CLASSIFICATION OF WASTES**

1. Bio-degradable wastes
2. Non-bio-degradable wastes

Substances that are broken down by biological process of biological or microbial action are called bio-degradable waste. e.g. wood, paper and leather.

Substances that are not broken down by biological or microbial action are called non-bio-degradable wastes. e.g. Plastic substances and mineral wastes.

#### **INTEXT QUESTIONS PAGE NO. 257**

**Q1. Why are some substances biodegradable and some non-biodegradable?**

**Ans:**

Some substances such as metal, glass, plastic, etc. which cannot be decomposed by the living organisms are non-biodegradable wastes. These substances are non-biodegradable because the micro-organisms do not have enzymes that can digest these substances. Therefore, we classify them as non-biodegradable wastes. Other substances such as paper, vegetable wastes, etc. that can be easily broken down by enzymes are biodegradable wastes.

**Q2. Give any two ways in which biodegradable substances would affect the environment.**

**Ans:**

- (i) Biodegradable substances act as a medium to return back the nutrients to the environment.

(ii) Their degradation may release certain gases in the atmosphere thereby polluting the environment.

**Q3. Give any two ways in which non-biodegradable substances would affect the environment.**

**Ans:**

- (i) They make the environment poisonous and unfit for survival.
- (ii) They block the transfer of energy and minerals in the ecosystem.

### **ECO-SYSTEM — WHAT ARE ITS COMPONENTS?**

A community of organisms that interact with one another and with the environment is called an ecosystem.

**An ecosystem has two types of components, viz. biotic component and abiotic component.**

Producers, consumers and decomposers are biotic factors.

#### **ABIOTIC COMPONENT**

All the non-living things make the abiotic component of an ecosystem. Air, water and soil are the abiotic components.

- ☞ Air provides oxygen (for respiration), carbon dioxide (for photosynthesis) and other gases for various needs of the living beings.
- ☞ Water is essential for all living beings because all the metabolic activities happen in the presence of water.
- ☞ Soil is the reservoir of various nutrients which are utilised by plants. Through plants, these nutrients reach other living beings.

#### **BIOTIC COMPONENT**

All living beings make the biotic component of an ecosystem.

- ☞ Green plants play the role of producers; because they prepare the food by photosynthesis.
- ☞ Animals and other living beings play the role of consumers; because they take food (directly or indirectly) from plants.
- ☞ Bacteria and fungi play the role of decomposers; as they decompose dead remains of plants and animals so that raw materials of organisms can be channelized back to the environment.

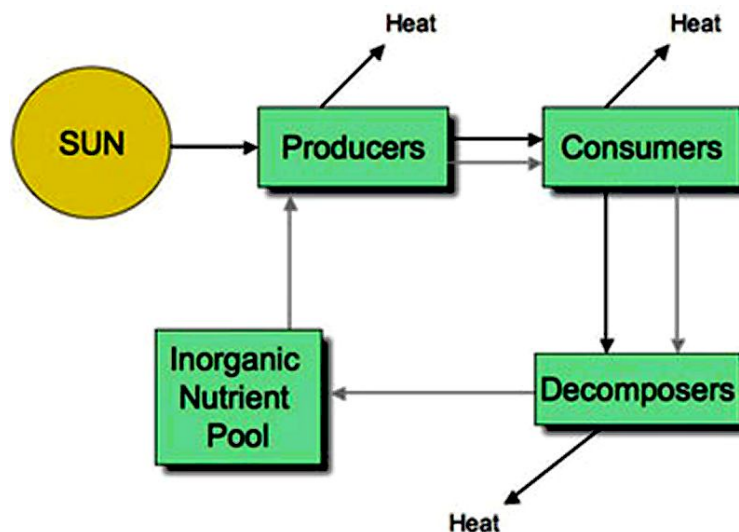

**Fig. Flow of energy in an ecosystem**

## **BALANCE IN ECO-SYSTEM**

A balanced ecosystem is an ecological community together with its environment and functioning as a complex unit. An ecosystem is maintained by the balance in nature such as the balance between hawks and mice, if hawk population is larger than the mice population, then it is not balanced. They are balanced between resources like a banana tree and monkeys. If the banana trees stop growing, the monkeys won't get bananas.

An ecosystem maintains the balance between the number of resources and the number of users or the balance between prey and predators.

## **FOOD CHAIN AND FOOD WEB**

The ultimate source of this energy is the sun. Producers like green plants trap solar energy and convert it into the chemical energy of food. When a primary consumer eats the producer, a part of this energy is passed on to it.

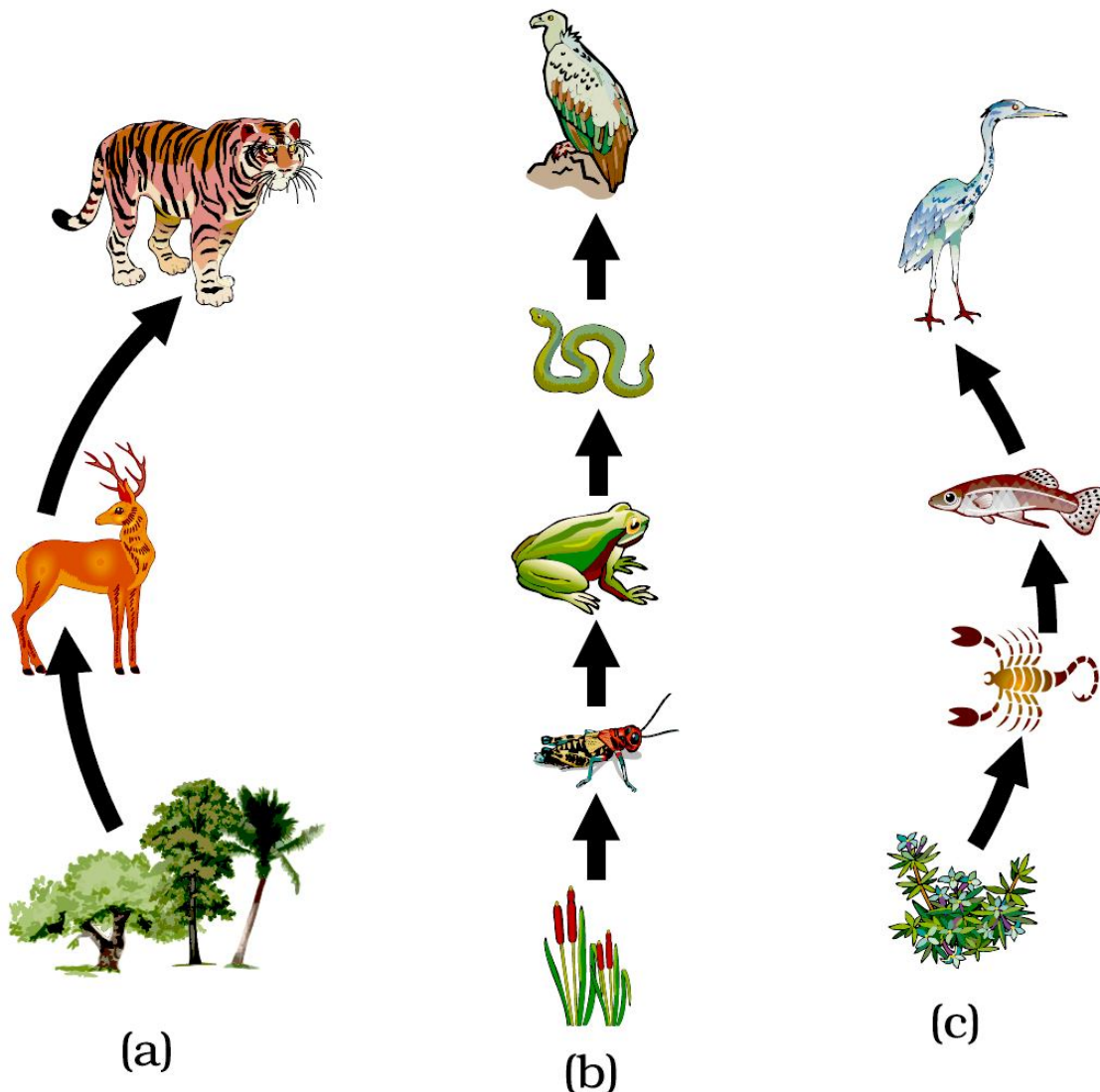

The primary consumer is then eaten by a secondary consumer. And the secondary consumer may be eaten by a tertiary consumer, and so on. In this way energy gets transferred from one consumer to the next higher level of consumer. A series of organisms through which food energy flows in an ecosystem is called a food chain. It may also be defined as follows.

*“A food chain in an ecosystem is a series of organisms in which each organism feeds on the one below it in the series.”*

In a forest ecosystem, grass is eaten by a deer, which in turn is eaten by a tiger. The grass, deer and tiger form a food chain. In this food chain, energy flows from the grass (producer) to the deer (primary consumer) to the tiger (secondary consumer) [see figure (a)].

A food chain in a grassland ecosystem may consist of grasses and other plants, grasshoppers, frogs, snakes and hawks [see figure (b)].

In a freshwater aquatic ecosystem like a pond, the organisms in the food chain include algae, small animals, insects and their larvae, small fish, big fish and a fish-eating bird or animal [see figure (c)].

A food chain always begins with producers. Herbivores (plant-eaters) come next in the chain. They are consumed by carnivores (flesh-eaters). A few food chains can be long and may extend to the fourth, fifth or even sixth order of consumers.

**Some common food chains are mentioned below:**

Plants → Deer → Lion

Plants → Worm → Bird → Cat

Plants → Grasshopper → Frog → Snake → Hawk

Algae → Small → animal → Small fish → Big fish → Bird

**FOOD WEB**

A food web is a graphical depiction of feeding connections among species of an ecological community. Food web consists of food chains of a particular ecosystem. The food web is an illustration of various methods of feeding that links the ecosystem. The food web also defines the energy flow through species of a community as a result of their feeding relationships. All the food chains are interconnected and overlapping within an ecosystem and they make up a food web. It increases the stability of ecosystem. It provides other source of food and allows the endangered species to grow.

**TROPHIC LEVELS OF FOOD CHAINS**

The levels of a food chain (food pyramid) is called **Trophic levels**. The trophic level of an organism is the level it holds in a food pyramid.

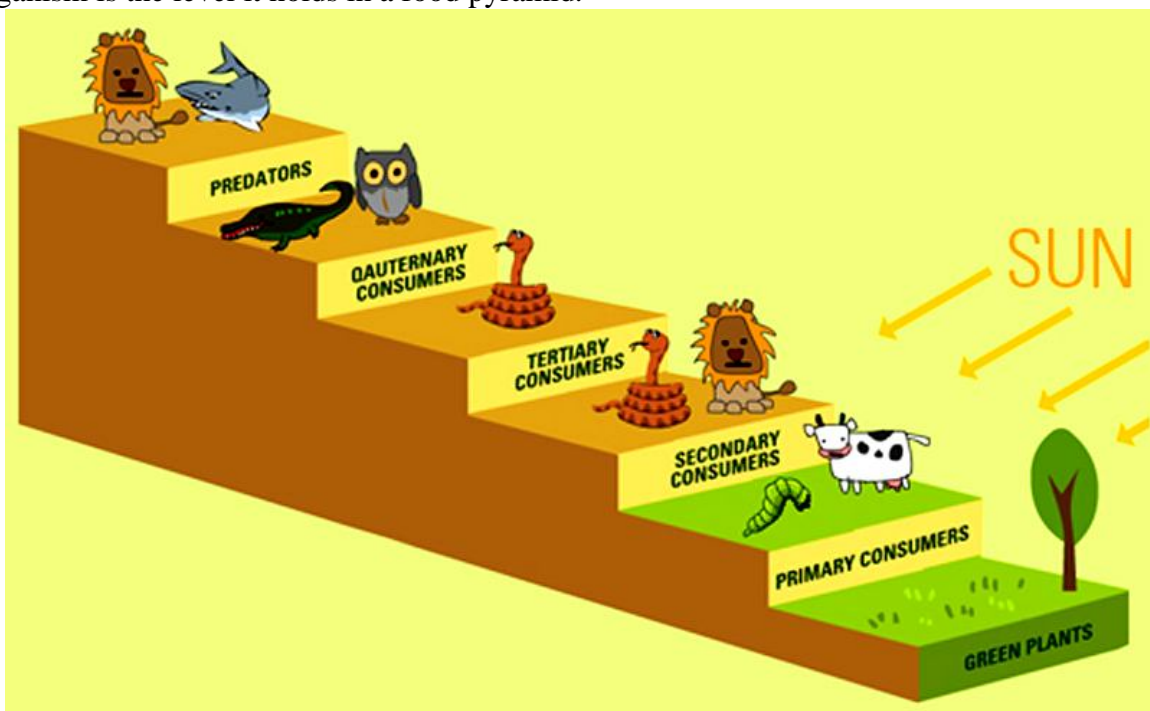

- ☞ The sun is the source of all the energy in food chains. Green plants, usually the first level of any food chain, absorb some of the Sun's light energy to make their own food by photosynthesis. Green plants (autotrophs) are therefore known as 'Producers' in a food chain.
- ☞ The second level of the food chains is called the Primary Consumer. These consume the green plants. Animals in this group are usually herbivores. Examples include insects, sheep, caterpillars and even cows.
- ☞ The third in the chain are Secondary Consumers. These usually eat up the primary consumers and other animal matter. They are commonly called carnivores and examples include lions, snakes and cats.
- ☞ The fourth level is called Tertiary Consumers. These are animals that eat secondary consumers.
- ☞ Quaternary Consumers eat tertiary consumers.
- ☞ At the top of the levels are Predators. They are animals that have little or no natural enemies. They are the 'bosses' of their ecosystems. Predators feed on preys. A prey is an animal that predators hunt to kill and feed on. Predators include owls, snakes, wild cats, crocodiles and sharks. Humans can also be called predators.
- ☞ When any organism dies, detritivores (like vultures, worms and crabs) eat them up. The rest are broken down by decomposers (mostly bacteria and fungi), and the exchange of energy continues. Decomposers start the cycle again.

### **ENERGY FLOW IS UNIDIRECTIONAL AND REQUIRES CONTINUOUS INPUTS.**

Ecosystem energy processes conform to the thermodynamic laws.

- Energy cannot be made or destroyed
- Energy transformations are not perfect and energy is lost in each transformation in the form of heat.

The flow of energy in the ecosystem is unidirectional. The energy enters the plants (from the sun) through photosynthesis during the making of food. This energy is then passed on from one organism to another in a food chain.

Energy given out by the organisms as heat is lost to the environment, it does not return to be used by the plants again. This makes the flow of energy in ecosystem 'unidirectional'. Thus, the flow of energy in the ecosystem is said to be unidirectional because the energy lost as heat from the living organisms of a food chain cannot be reused by plants in photosynthesis.

During the transfer of energy through successive trophic levels in an ecosystem, there is a loss of energy all along the path. No transfer of energy is 100 per cent. The energy available at each successive trophic level is 10 per cent of the previous level. Thus, there is a progressive decline (gradual reduction) in the amount of energy available as we go from producer level to the higher trophic levels of organisms.

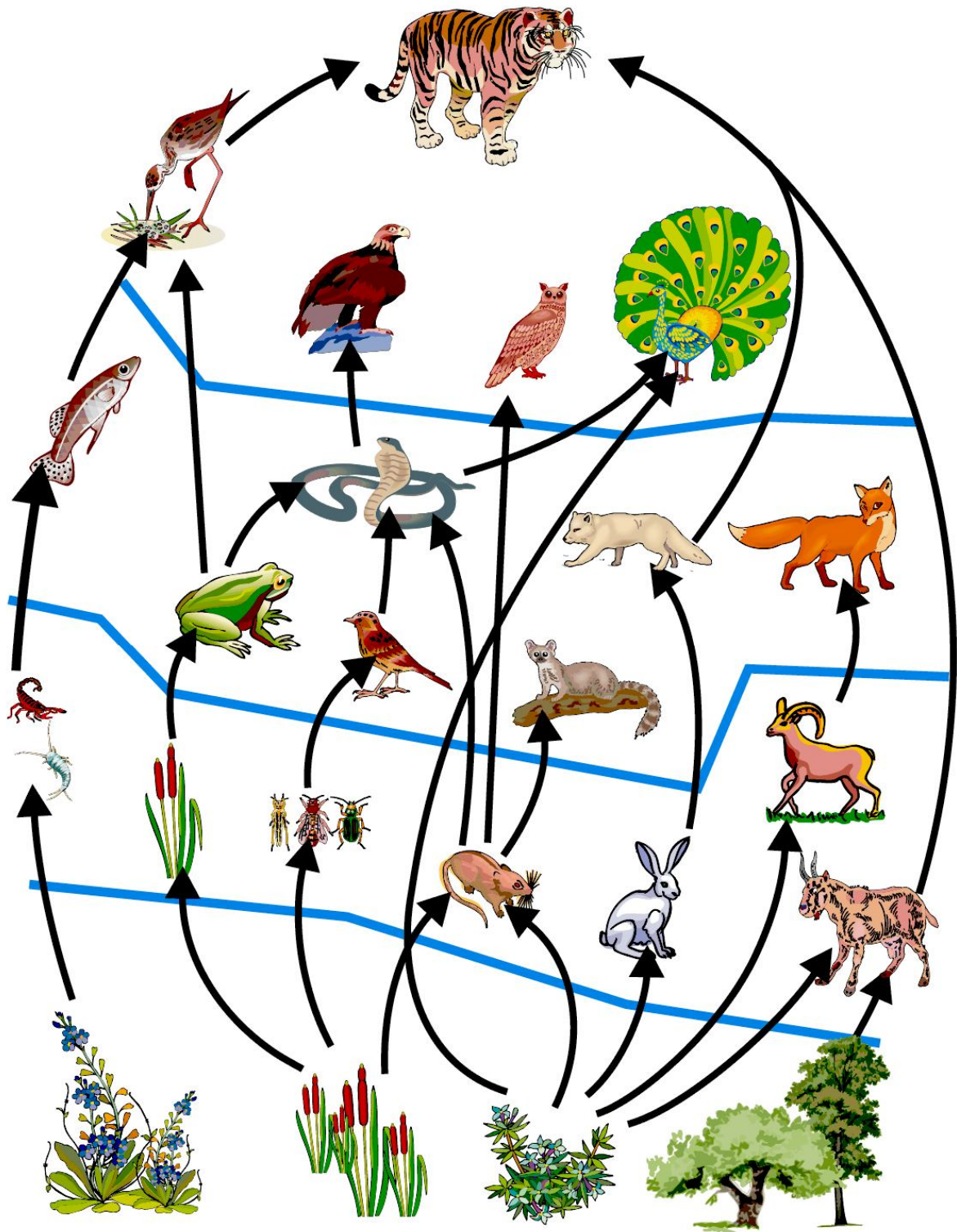

*Food web, consisting of many food chains*

The nutrient movement is a cyclic movement where the nutrients revolve round with an ecosystem, hence cyclic. Nutrients pass from abiotic nutrient stores, such as the soil and the atmosphere, into biotic, plant and animal stores (the biomass). The nutrients are then recycled, within the ecosystem, following death and decomposition.

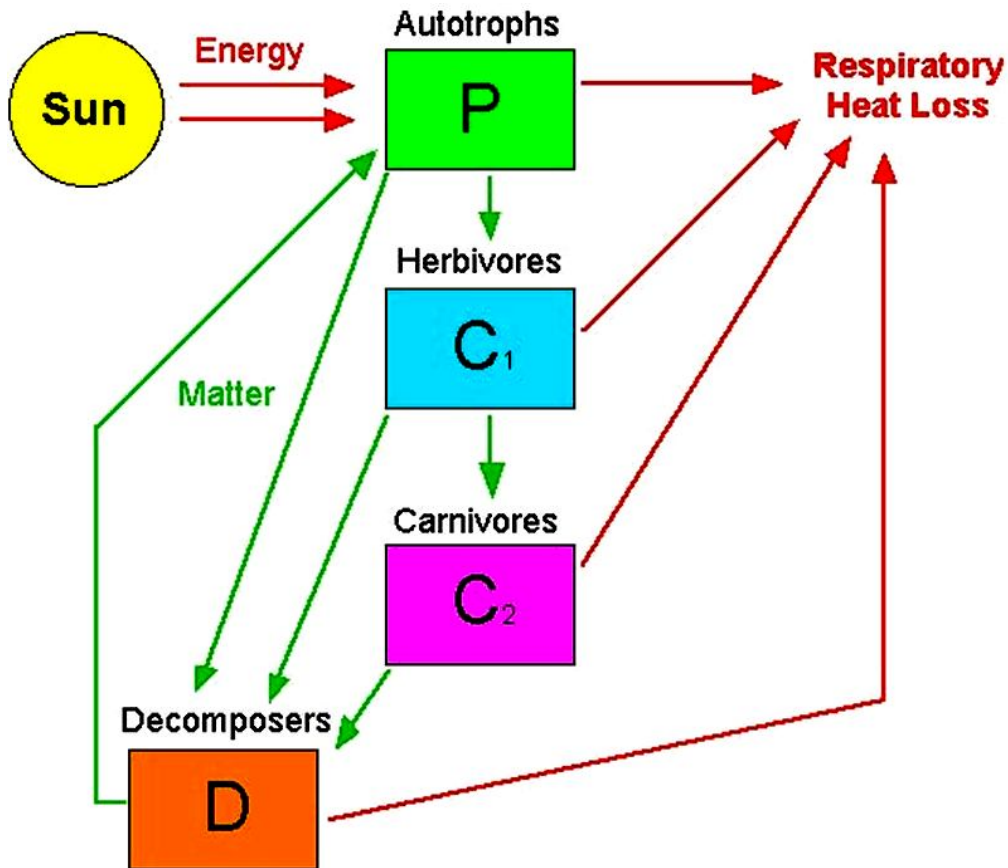

**INTEXT QUESTIONS PAGE NO. 261**

**Q1. What are trophic levels? Give an example of a food chain and state the different trophic levels in it.**

**Ans:**

Each stage of a **food chain** is known as trophic level.

Trees	→	Rabbit	→	Snake	→	Hawk
(First trophic level)		(Second trophic level)		(Third trophic level)		(Fourth trophic level)
(Producers)		(I consumers)		(II consumer)		(III consumer)

**Q2. What is the role of decomposers in the ecosystem?**

**Ans:**

Decomposers include micro-organisms such as bacteria and fungi that obtain nutrients by breaking down the remains of dead plants and animals. They help in the breakdown of organic matter or biomass from the body of dead plants and animals into simple inorganic raw materials, such as CO<sub>2</sub>, H<sub>2</sub>O, and some nutrients.

**OZONE LAYER DEPLETION**

Ozone (O<sub>3</sub>) is a molecule formed by three atoms of oxygen. While O<sub>2</sub>, which we normally refer to as oxygen, is essential for all aerobic forms of life. Ozone, is a deadly poison. However, at the higher levels of the atmosphere, ozone performs an essential function. It shields the surface of the earth from ultraviolet (UV) radiation from the Sun. This radiation is highly damaging to organisms, for example, it is known to cause skin cancer in human beings.

Ozone at the higher levels of the atmosphere is a product of UV radiation acting on oxygen ( $O_2$ ) molecule. The higher energy UV radiations split apart some molecular oxygen ( $O_2$ ) into free oxygen (O) atoms. These atoms then combine with the molecular oxygen to form ozone as shown—

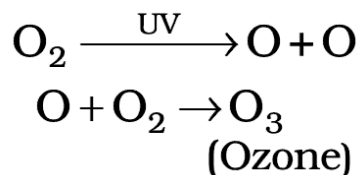

The amount of ozone in the atmosphere began to drop sharply in the 1980s. This decrease has been linked to synthetic chemicals like chlorofluorocarbons (CFCs) which are used as refrigerants and in fire extinguishers. In 1987, the United Nations Environment Programme (UNEP) succeeded in forging an agreement to freeze CFC production at 1986 levels.

### **HOW TO PROTECT US FROM THESE HAZARDOUS WASTES ?**

The following methods are adopted for the disposal of harmful waste materials.

#### **1. Land Fills**

There are permanent storage facilities in secured lands for military related liquid and radioactive waste materials. High level radioactive wastes are stored in deep underground storage.

#### **2. Deep well injection**

It involves drilling a well into dry porous material below ground water. Hazardous waste liquids are pumped into the well. They are soaked into the porous material and made to remain isolated indefinitely.

#### **3. Incineration**

The burning of materials is called incineration. Hazardous bio-medical wastes are usually disposed off by means of incineration. Human anatomical wastes, discarded medicines, toxic drugs, blood, pus, animal wastes, microbiological and bio-technological wastes etc., are called bio-medical wastes.

## **MANAGEMENT OF NON-HAZARDOUS WASTES – SOLID WASTE MANAGEMENT**

### **Reuse and recycling technique**

The separating out of materials such as rubber, glass, paper and scrap metal from refuse and reprocessing them for reuse is named as reclamation of waste or recycling.

#### **Paper**

(54% recovery) Can be repulped and reprocessed into recycled paper, cardboard and other products.

#### **Glass**

(20% recovery) Can be crushed, remelted and made into new containers or crushed used as a substitute for gravel or sand in construction materials such as concrete and asphalt, Food waste and yard wastes (leaves, grass etc.,) can be composted to produce humus soil conditioner.

### **INTEXT QUESTIONS PAGE NO. 264**

#### **Q1. What is ozone and how does it affect any ecosystem?**

##### **Ans:**

Ozone is chemically  $O_3$  molecule. Ozone layer is present in the stratosphere layer of atmosphere. It absorbs most of ultraviolet radiations coming from the Sun.



Ozone gas is poisonous in nature, if inhaled.

**Q2. How can you help in reducing the problem of waste disposal? Give any two methods.**

**Ans:**

- (i) Using biodegradable materials
- (ii) Using recyclable materials.

**EXERCISE QUESTIONS PAGE NO. 159**

**Q1. Which of the following groups contain only biodegradable items?**

- (a) Grass, flowers and leather
- (b) Grass, wood and plastic
- (c) Fruit-peels, cake and lime-juice
- (d) Cake, wood and grass

**Ans:**

- (c) Fruit-peels, cake, and lime-juice
- (d) Cake, wood, and grass

Substances that are broken down by the biological processes are said to be biodegradable, *e.g.*, fruit, cake, lime-juice, wood, grass, etc.

**Q2. Which of the following constitute a food-chain?**

- (a) Grass, wheat and mango
- (b) Grass, goat and human
- (c) Goat, cow and elephant
- (d) Grass, fish and goat

**Ans:**

- (b) Grass, goat and human

Each step of food chain form a trophic level. Producers (grass) form the first trophic level, herbivore (goat) the second and carnivore (human) the third trophic level.

**Q3. Which of the following are environment-friendly practices?**

- (a) Carrying cloth-bags to put purchases in while shopping
- (b) Switching off unnecessary lights and fans
- (c) Walking to school instead of getting your mother to drop you on her scooter
- (d) All of the above

**Ans:**

- (d) All of the above

Cloth-bags are biodegradable, switching off unnecessary light and fans and limited use of petrol/diesel cause less pollution hence, environment friendly practices.

**Q4. What will happen if we kill all the organisms in one trophic level?**

**Ans:**

If we kill all the organisms in one trophic level, the lower trophic level will grow more in number and the higher trophic level will not survive and flow of energy from one trophic level to other will not take place.

**Q5. Will the impact of removing all the organisms in a trophic level be different for different trophic levels? Can the organisms of any trophic level be removed without causing any damage to the ecosystem?**

**Ans:**

The impact of removing all the organism in a trophic level will be different for different trophic levels. The lower trophic level of an ecosystem has a greater number of individuals

than the higher trophic levels. If the organisms of any trophic level are removed they cause a damage to the ecosystem. Removal of producers will affect all the organisms and they won't survive. The removal of higher trophic level will lead to increase in organisms of lower trophic level and the organisms die due to shortage of food.

**Q6. What is biological magnification? Will the levels of this magnification be different at different levels of the ecosystem?**

**Ans:**

The accumulation of chemicals in the individuals of higher trophic level is called biological magnification.

No, the levels of magnification is not same in all trophic levels. The chemicals are not degraded and get accumulate progressively at each trophic level which lead to biomagnification. Biomagnification is more in organisms of higher trophic levels.

**Q7. What are the problems caused by the non-biodegradable wastes that we generate?**

**Ans:**

**Non-biodegradable substances affect the environment in the following ways:**

- (i) Since the non-biodegradable substances cannot be broken down, they get accumulated and thus contaminate the soil and the water resources.
- (ii) These substances, when accidentally eaten by some stray animal, can harm them and can even cause their death.
- (iii) These substances occupy more space in the landfills and require special disposal techniques.
- (iv) These materials can accumulate in the environment and can also enter the food chain.

**Q8. If all the waste we generate is biodegradable, will this have no impact on the environment?**

**Ans:**

If all the waste is biodegradable, then there will be no accumulation of waste and the Earth would be a cleaner place to live. But if this biodegradable waste is too large in amount then its degradation may lead to air pollution (due to release of gases).

**Q9. Why is damage to the ozone layer a cause for concern? What steps are being taken to limit this damage?**

**Ans:**

The thinning of ozone layer present in stratosphere is called depletion of ozone layer. Due to depletion of ozone layer, harmful ultraviolet radiations will reach the surface of Earth which may lead to skin diseases and cancer.

To reduce the depletion of ozone layer, the use of chlorofluorocarbons has been minimised.

.....

**ASSIGNMENT QUESTIONS SET – 1**  
**CHAPTER – 15**  
**OUR ENVIRONMENT**

1. What percentage of sunlight is captured by plants to convert it into food energy?
  - (a) 1%
  - (b) 10%
  - (c) 50%
  - (d) more than 50%
2. Flow of energy in an ecosystem is always
  - (a) unidirectional
  - (b) bidirectional
  - (c) multidirectional
  - (d) none of these
3. Which of the following is non-biodegradable?
  - (a) Tea leaves
  - (b) Nylon
  - (c) remains of animals
  - (d) fleece of sheep
4. The structural and functional unit of the environment is known as:
  - (a) ecosystem
  - (b) biosphere
  - (c) food chain
  - (d) food web
5. Depletion of ozone layer is mainly due to
  - (a) Methane
  - (b) Carbon Dioxide
  - (c) ChloroFloroCarbons
  - (d) Nitrogen
6. First order consumers are:
  - (a) Carnivores
  - (b) Herbivores
  - (c) Decomposers
  - (d) Omnivores

7. A detritus food chain begins with
- (a) Carnivores
  - (b) Herbivores
  - (c) Omnivores
  - (d) Decomposers
8. In an ecosystem, the 10% of energy disposable for transfer from one trophic level to next is in the form of
- (a) heat energy
  - (b) chemical energy
  - (c) mechanical energy
  - (d) light energy
9. Accumulation of non-biodegradable pesticides in the food chain in increasing amount at each higher trophic level is known as
- (a) eutrophication
  - (b) pollution
  - (c) biomagnification
  - (d) accumulation
10. Which of the following is an abiotic component
- (a) plants
  - (b) animals
  - (c) soil
  - (d) microorganisms
11. Which of the statement is incorrect?
- (a) All green plants and blue green algae are producers
  - (b) Green plants get their food from organic compounds
  - (c) Producers prepare their own food from inorganic compounds
  - (d) Plants convert solar energy into chemical energy
12. Edaphic factors are included in
- (a) Abiotic components
  - (b) Biotic components
  - (c) Producers
  - (d) Consumers
13. Only \_\_\_\_ % of the energy can be transferred from one trophic level to the next trophic level.
- a) 1

- b) 5
- c) 10
- d) 20

**14.** Accumulation of non- biodegradable pesticides in different trophic levels is called

- a) Biological degradation
- b) Biological magnification
- c) Biological concentration
- d) Biological deposition

**15.** The UV radiation from the sun is likely to cause \_\_\_\_\_ in human.

- a) Skin cancer
- b) Lung cancer
- c) Liver Cancer
- d) Brain Cancer

**16.** World Environment day is celebrated on

- a) July 1
- b) July 5
- c) June 1
- d) June 5

**17.** Which one of the following is a non- biodegradable substance

- a) DDT
- b) Manure
- c) paper
- d) Cotton cloth

**18.** In a terrestrial ecosystem the biomass of \_\_\_\_\_ should be the most

- a) Herbivore
- b) Carnivore
- c) Producer
- d) Any one of the above

**19.** Identify the proper food chain

- a) Grass ----- frog ---- insect ----- snake
- b) Grass---- insect ----- frog ----- snake
- c) Insect --- frog ---- grass ---- snake
- d) Grass --- frog ---- snake ----- insect

**20.** Food web is

- a) Food served through websites

- b) Display of different food items
  - c) Interlinked food chains
  - d) Using food items for a fashion dress
21. The best way to dispose waste is by
    - a) Making a paste of all domestic waste and putting them in a river
    - b) Separating biodegradable and nonbiodegradable waste before disposing in bins
    - c) Throw the waste on road side
    - d) Dumping all domestic waste in litter bin
  22. Which of the following organism is likely to have maximum concentration of DDT : Algae, fish, water flea, frog, bird
  23. What is the role of bacteria and fungi in an ecosystem?
  24. What are trophic levels?
  25. How much energy is transferred to the next trophic level in a food chain?
  26. Which trophic level has the highest concentration of toxic substances in a food chain?
  27. Mention some sources of CFC's.
  28. Distinguish between a food chain & a food web
  29. What would happen if there are no decomposers on earth?
  30. What is a food chain? Write a five step food chain found in grass land with frog as one of the members. What will happen to organisms at different trophic levels if all the frogs are removed?
  31. The number of malaria patients increased tremendously when a large number of frogs were exported from the village .What could be the cause for it? Explain with the help of a food chain.
  32. What are the problems caused by the non-biodegradable wastes that we generate?
  33. Food chains generally consist of only 3 or 4 trophic levels. Why is it so?
  34. Observe the food chain Plant (1000 kJ) --- >Goat ---> Lion (a) If autographs occupying the first trophic level are called producers what are herbivores Called as? (b) How much energy does the lion get in the above food chain?
  35. Vegetarian or non vegetarian food habit help us in getting more energy. Why?
  36. How is ozone formed in the upper atmosphere? Why is the damage of ozone layer a cause of concern to us? State cause of this damage.
  37. What is environment?
  38. What happens when we add our waste to the environment or throw?
  39. What are the different types of waste materials?
  40. What happens after we throw waste away them away?

41. Why are some substances biodegradable and some non-biodegradable?
42. What are the harmful effects of biodegradable substance?
43. What are the harmful effects of non- biodegradable substance?
44. Name some of the biodegradable plastics.
45. What are the differences between biodegradable and non-biodegradable wastes. What is Ecosystem? What are the different types of Ecosystem?
46. Why does aquarium have to be cleaned once in a while?
47. Do we have to clean ponds or lakes in the same manner of aquarium? Why or why not?
48. What are the different components of echo system?
49. What are trophic levels? Give an example of a food chain and state the different trophic levels in its.
50. What is the role of decomposers in the ecosystem?
51. What are the importances of decomposers?
52. What is a food chain?
53. What is food web?
54. Define the term 'biome'.
55. What are the significances of food Chains?
56. How do flows of energy occur in tropic level?
57. What are the characteristics of energy transfer in the biosphere?
58. Why is energy flow considered as unidirectional?
59. What is biomass?
60. Define biomagnifications.
61. How does a food web an important factor of our environment? Describe its four benefits.
62. What is 10% Law?
63. How much energy will be available to hawks in the food chain comprising hawk, snake, paddy and mice, if 1,000 J of energy is available to wheat plants from the sun?
64. Differentiate between food chain and food web?
65. Why is damage to the ozone layer a cause of concern? What steps are being taken to limit this damage?
66. Which compounds are responsible for the depletion of ozone layer?
67. Which disease is caused in human being due to depletion of ozone layer in the atmosphere?
68. Why is ozone layer getting depleted at higher levels of the atmosphere?
69. How is ozone formed in the upper atmosphere? Which compounds are responsible for the depletion of ozone layer?
70. When is World Ozone Layer Preservation Day celebrated?

71. What is green house effect?
  72. Suggest activities in our daily life which are eco friendly.
  73. How can you help in reducing the problem of waste disposal? Give any two methods.
  74. What is the importance of phytoplankton?
  75. Which pollutants are contributed by airplanes?
  76. How is ozone layer formed in the atmosphere? What is the function of this layer?
  77. Name any two biodegradable wastes.
  78. Name any two non-biodegradable wastes.
  79. Name two aquatic ecosystems.
  80. Name two terrestrial ecosystems.
  81. Give two examples of Artificial ecosystems.
  82. Which is the ultimate source of the energy for an ecosystem?
  83. Name the category of organism which feed the energy into the ecosystems.
  84. Give the scientific term for organisms which feed directly on plants.
  85. How much of organic matter is available at each trophic level to reach the next level?
  86. Name the type of organisms that occupy (i) the first trophic level and (ii) the second trophic level.
  87. Define Biomagnification.
  88. Expand UNEP.
  89. Name the chemical mainly responsible for the damage of ozone layer.
  90. Where are CFCs used?
- .....



**ASSIGNMENT QUESTIONS SET – 2**  
**CHAPTER – 15**  
**OUR ENVIRONMENT**

1. Which one of the following is an artificial ecosystem?
  - (a) Pond
  - (b) Crop field
  - (c) Lake
  - (d) Forest
2. In a food chain, the third trophic level is always occupied by
  - (a) carnivores
  - (b) herbivores
  - (c) decomposers
  - (d) producers
3. An ecosystem includes
  - (a) all living organisms
  - (b) non-living objects
  - (c) both living organisms and non-living objects
  - (d) sometimes living organisms and sometimes non-living objects
4. In the given food chain, suppose the amount of energy at fourth trophic level is 5 kJ, what will be the energy available at the producer level?

Grass → □ Grasshopper → □ Frog → □ Snake → □ Hawk

  - (a) 5 k J
  - (b) 50 k J
  - (c) 500 k J
  - (d) 5000 k J
5. Accumulation of non-biodegradable pesticides in the food chain in increasing amount at each higher trophic level is known as
  - (a) eutrophication
  - (b) pollution
  - (c) biomagnification
  - (d) accumulation
6. Depletion of ozone is mainly due to
  - (a) chlorofluorocarbon compounds
  - (b) carbon monoxide

- (c) methane  
(d) pesticides
7. Organisms which synthesise carbohydrates from inorganic compounds using radiant energy are called
- (a) decomposers                      (b) producers  
(c) herbivores                        (d) carnivores
8. In an ecosystem, the 10% of energy available for transfer from one trophic level to the next is in the form of
- (a) heat energy                              (b) light energy  
(c) chemical energy                        (d) mechanical energy
9. Organisms of a higher trophic level which feed on several types of organisms belonging to a lower trophic level constitute the
- (a) food web                                (b) ecological pyramid  
(c) ecosystem                                (d) food chain
10. Flow of energy in an ecosystem is always
- (a) unidirectional                              (b) bidirectional  
(c) multi directional                        (d) no specific direction
11. Excessive exposure of humans to U V-rays results in
- (i) damage to immune system  
(ii) damage to lungs  
(iii) skin cancer  
(iv) peptic ulcers  
(a) (i) and (ii) (b) (ii) and (iv)  
(c) (i) and (iii) (d) (iii) and (iv)
12. In the following groups of materials, which group (s) contains only non-biodegradable items?
- (i) Wood, paper, leather  
(ii) Polythene, detergent, PVC  
(iii) Plastic, detergent, grass  
(iv) Plastic, bakelite, DDT  
(a) (iii) (b) (iv)  
(c) (i) and (iii) (d) (ii) and (iv)
13. Which of the following limits the number of trophic levels in a food chain?
- (a) Decrease in energy at higher trophic levels  
(b) Dufficient food supply

- (c) Polluted air
- (d) Water

14. Which of the statement is incorrect?

- (a) All green plants and blue green algae are producers
- (b) Green plants get their food from organic compounds
- (c) Producers prepare their own food from inorganic compounds
- (d) Plants convert solar energy into chemical energy

15. Which group of organisms are not constituents of a food chain?

- (i) Grass, lion, rabbit, wolf
  - (ii) Plankton, man, fish, grasshopper
  - (iii) Wolf, grass, snake, tiger
  - (iv) Frog, snake, eagle, grass, grasshopper
- (a) (i) and (iii)      (b) (iii) and (iv)  
 (c) (ii) and (iii)    (d) (i) and (iv)

16. The percentage of solar radiation absorbed by all the green plants for the process of photosynthesis is about

- (a) 1 %      (b) 5 %      (c) 8 %      (d) 10 %

17. In the given below Figure the various trophic levels are shown in a pyramid. At which trophic level is maximum energy available?

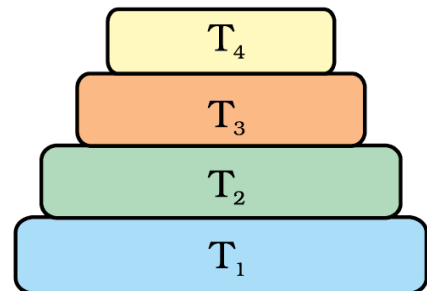

- (a) T<sub>4</sub>
- (b) T<sub>2</sub>
- (c) T<sub>1</sub>
- (d) T<sub>3</sub>

18. What will happen if deer is missing in the food chain given below?

Grass → Deer → Tiger

- (a) The population of tiger increases
- (b) The population of grass decreases
- (c) Tiger will start eating grass
- (d) The population of tiger decreases and the population of grass increases

19. The decomposers in an ecosystem

- (a) convert inorganic material, to simpler forms
- (b) convert organic material to inorganic forms
- (c) convert inorganic materials into organic compounds
- (d) do not breakdown organic compounds

- 20.** If a grass hopper is eaten by a frog, then the energy transfer will be from
- (a) producer to decomposer
  - (b) producer to primary consumer
  - (c) primary consumer to secondary consumer
  - (d) secondary consumer to primary consumer
- 21.** Disposable plastic plates should not be used because
- (a) they are made of materials with light weight
  - (b) they are made of toxic materials
  - (c) they are made of biodegradable materials
  - (d) they are made of non-biodegradable materials
- 22.** Why is improper disposal of waste a curse to environment?
- 23.** Write the common food chain of a pond ecosystem.
- 24.** What are the advantages of cloth bags over plastic bags during shopping?
- 25.** Why are crop fields known as artificial ecosystems?
- 26.** Differentiate between biodegradable and non-biodegradable substances. Cite examples.
- 27.** Suggest one word for each of the following statements/ definitions
- (a) The physical and biological world where we live in
  - (b) Each level of food chain where transfer of energy takes place
  - (c) The physical factors like temperature, rainfall, wind and soil of an ecosystem
  - (d) Organisms which depend on the producers either directly or indirectly for food
- 28.** Explain the role of decomposers in the environment?
- 29.** We do not clean ponds or lakes, but an aquarium needs to be cleaned. Why?
- 30.** Indicate the flow of energy in an ecosystem. Why is it unidirectional? Justify.
- 31.** What are decomposers? What will be the consequence of their absence in an ecosystem?
- 32.** Suggest any four activities in daily life which are eco-friendly.
- 33.** Give two differences between food chain and food web.
- 34.** Name the wastes which are generated in your house daily. What measures would you take for their disposal?
- 35.** Suggest suitable mechanism (s) for waste management in fertiliser industries.
- 36.** What are the by-products of fertiliser industries? How do they affect the environment?
- 37.** Explain some harmful effects of agricultural practices on the environment.

**38. ACTIVITY BASED QUESTION:** Given below is the pictorial representation of a terrestrial food chain and a marine chain. Observe them carefully and answer the questions given in the worksheet.

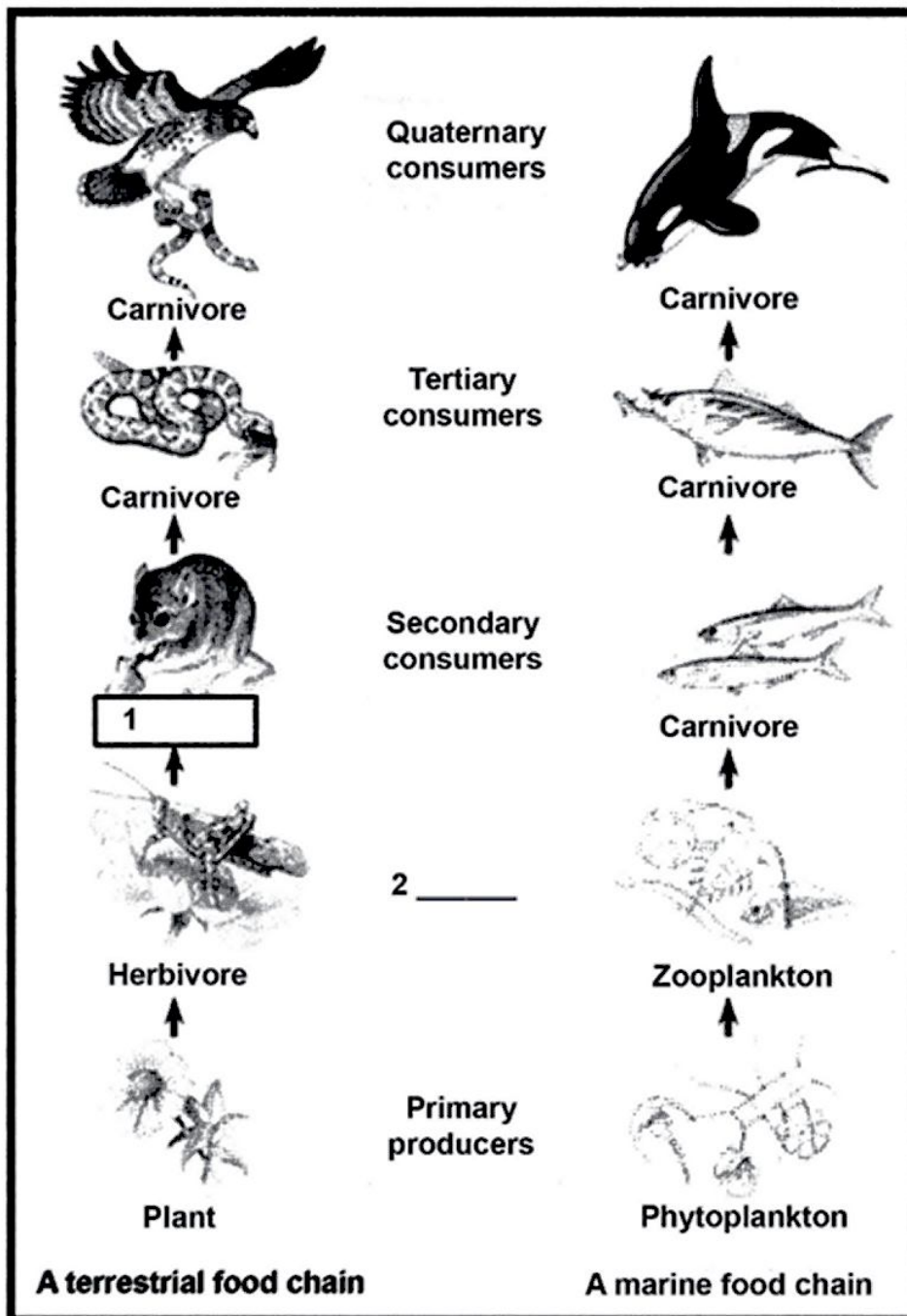

- ☞ Fill in the blank in the terrestrial food chain (Blank no. 1). Why is the rat given this term?
- ☞ Can the rat come at a lower position in the terrestrial food chain? Give reasons for your answer.
- ☞ Fill up the blank no. 2. Write one common feature of all organisms that are placed at this level in a food chain.
- ☞ What will be the fate of this terrestrial food chain if all the rats were removed?

☞ Will the food chains be affected if the animals at the top carnivore level were removed?

Give reasons for your answer.

39. Name four biotic and four abiotic components observed in this area.

40. Will this place be called a natural ecosystem or an artificial ecosystem? Give reasons for your answer.

41. List four producers and four consumers present in this area.

42. Construct one food chain that operates in this area. Identify the producers, primary consumers, secondary consumers and tertiary consumers (if any) in the food chain.

43. Write any two points of environmental concern that have arisen in the area due to human intervention.

.....



Wish You All the Best For Your Future